



SIB 11 02 21  
SERVICE ACTION: REPLACE CYLINDER HEAD

2021-03-15

**MODEL**

E-Series	Model Description	Production Date
K67	S 1000 RR	To May 17, 2020

The affected vehicles have been marked with campaign number 0011460000 in AIR.

In order to determine if a specific vehicle is affected by this campaign it will be necessary to verify the vehicle VIN in AIR (Aftersales Information Research). Based on the response of the system, either proceed with the repair or take no further action. Please note, open campaigns or vehicle stops may not appear in DCS Warranty Vehicle Inquiry or sales systems until 24-72 hours after they are announced, therefore AIR is always the recommended method for determining open campaigns and vehicle stops.

## SITUATION

In the production of the titanium valves, a process deviation occurred in the surface coating of a production lot. The changed surface can result in increased wear of the valve guides over the service life.

For vehicles that have already been delivered, customers will be notified by BMW via first class mail. The letter will describe the situation and ask them to schedule an appointment as soon as possible to have the Technical Campaign carried out.

For vehicles that have not been delivered, the service campaign must be carried out **before delivery** to customers.

## CORRECTION

Engines produced since May 18, 2020 do not exhibit this condition and are not included in this campaign.

## PROCEDURE

Replace Cylinder Head. See repair instruction "00 60 383 Replace cylinder head"

NOTICE: Cylinder heads ship from the factory with certain bolts that will need to be tightened by the technician.

Screws for rocker arm axle are tightened with only 1 Nm from factory and need to be retightened to the specification shown below. A new sealing ring is not necessary.

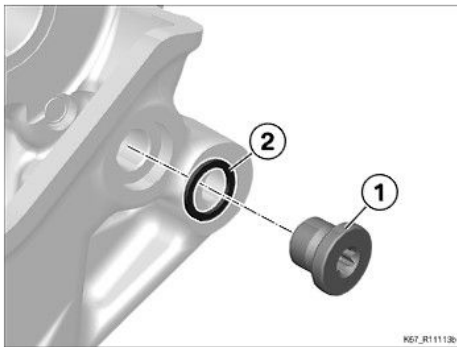

- Renew sealing ring (2).
- Install screw plug (1) with sealing ring (2).

Tightening torques		
Threaded plug (cam-follower shaft) to cylinder head		
M10 x 1	10 Nm	

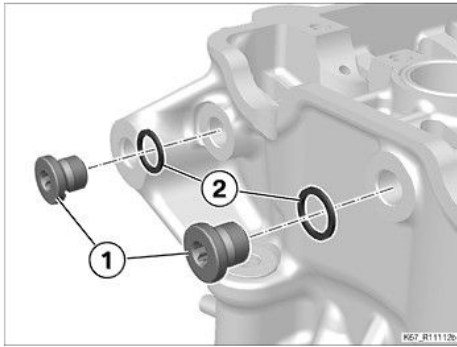

- Renew sealing rings (2).
- Install screw plugs (1) with sealing rings (2).

Tightening torques		
Threaded plug (cam-follower shaft) to cylinder head		
M10 x 1	10 Nm	

## PARTS INFORMATION

### Part Number

11 12 7 105 934	Cylinder head with valves
06 32 7 657 949	2× Bolt to MK oil cooler
06 32 7 727 783	Bolt M6×16 MK - Oil cooler return line to engine
07 11 9 909 546	O-ring (37.82×1.78) for housing cover screw plug, right
07 11 9 963 252	3× Sealing ring chain tensioner guides, oil drain plug
07 11 9 963 340	Sealing ring A20x24-AL
07 12 9 909 586	Cheese head screw MK to manifold
07 14 6 778 500	2× Nut M6
11 12 7 726 964	Set, O-ring for shaft coil
11 12 9 480 983	Gasket set for cylinder head cover and secondary air system
11 12 9 899 963	10× Cylinder head bolts
11 14 8 358 847	2× O-ring for switching cam actuator
13 53 9 480 898	O-ring for fuel pressure line
13 62 8 658 854	3× O-ring (switching cam sensor, camshaft sensor, crankshaft sensor)
13 64 7 675 557	3× O-ring for fuel injectors
17 22 7 680 668	2× O-ring for oil cooler to crankcase
18 51 8 542 088	4× Gasket, exhaust manifold
23 00 8 569 916	Locking washer (tab) pinion
23 00 8 569 927	Nut pinion 24×1.5

### Part number as needed

11 11 7 717 367	2× Fitting sleeve
11 12 8 569 342	Cylinder head gasket (1.02 mm 1-hole)
11 12 8 569 343	Cylinder head gasket (1.12 mm 2-hole)

## WARRANTY INFORMATION

Covered under the terms of the BMW New Vehicle Limited Warranty for Motorcycles, if applicable.

### Defect code

00 11 46 00 00	Replace cylinder head
----------------	-----------------------

### Labor Operation

00 60 383	Replace cylinder head	77 FRU
+00 60 883	Replace cylinder head	76 FRU
00 60 993	Bonus time for Technical Campaign	18 FRU

FRUs includes all repair procedures to complete the task with allowance for necessary ancillary tasks (e.g., visual inspection, lubrication, cleaning parts etc.) and administrative tasks.

Labor operation code 00 60 383 is a Main labor operation. If you are using a Main labor code for another repair, use the Plus code labor operation instead.

## QUESTIONS REGARDING THIS BULLETIN

Technical inquiries	Contact the BMW Technical Support Group via TSARA
Warranty inquiries	Submit an IDS ticket to the Warranty Department
Parts inquiries	Submit an IDS ticket to the Motorrad Parts Department

### Supporting Materials

[picture\\_as\\_pdf 11 02 21 Repair Manual.pdf](#)

[picture\\_as\\_pdf 11 02 21 SA Replace cylinder head.pdf](#)

[picture\\_as\\_pdf 11 02 21 Additional Tightening Torque Info.pdf](#)

### Videos

[11 02 21](#)

[11 01 21](#)

[11 03 21](#)

## 0E23 - S 1000 RR

### 00 60 383 Replace cylinder head

Additional work: 46 52 510 Removing and installing the rear-wheel stand special tool (motorcycles without centre stand)

# 1

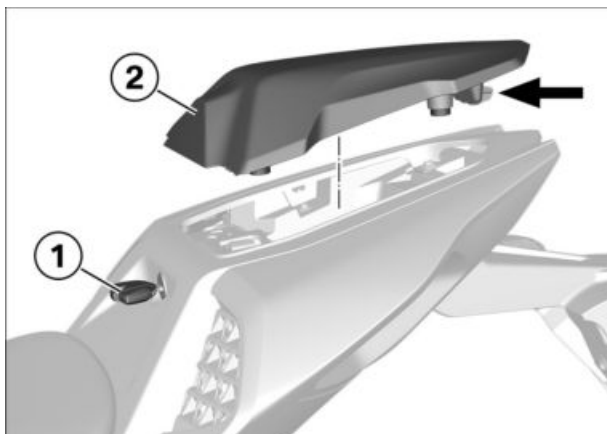

#### ► Removing tail-hump cover

- Using an ignition key **(1)** unlock the lock for tail-hump cover **(2)**.
- Remove tail-hump cover **(2)**, to unhook the fixture **(arrow)**.

# 2

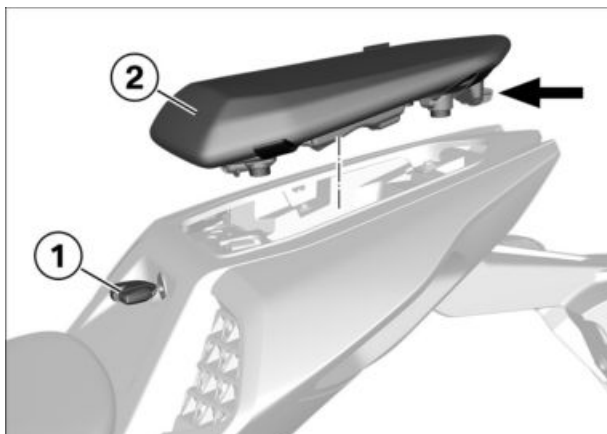

#### ► Removing passenger seat

– with two-up riding package<sup>OE</sup> (0413)

- Using an ignition key **(1)** unlock the lock for passenger seat **(2)**.
- Remove passenger seat **(2)**, to unhook the fixture **(arrow)**.◇

### 3

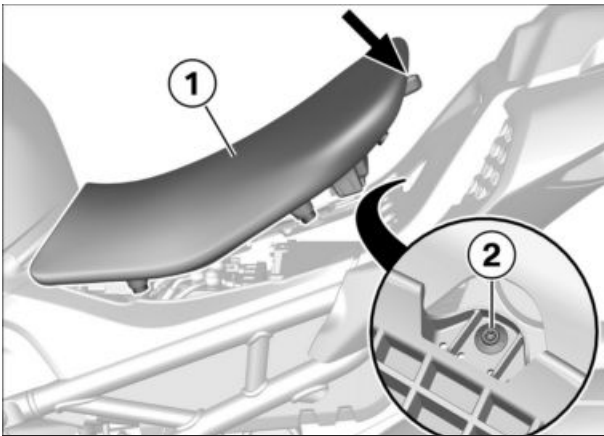

#### ► Removing rider's seat

- Push driver's seat **(1)** on the seat cushion surface **(arrow)** forwards.
- Loosen bolt **(2)**.
- Raise the driver's seat **(1)** at the rear and remove.



### 4

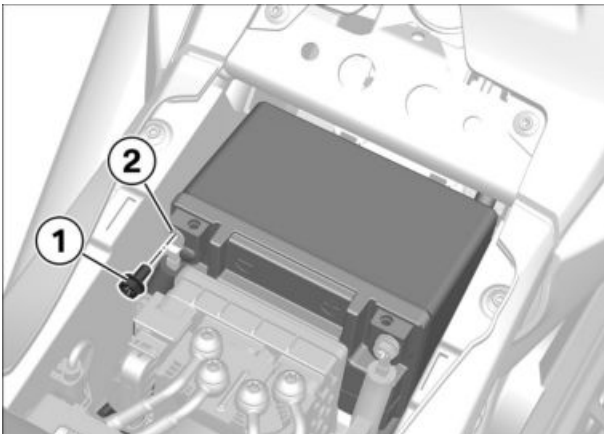

#### ► Disconnect battery from vehicle

- Remove screw **(1)** and remove wiring harness negative terminal **(2)** and insulate, for instance with adhesive tape.

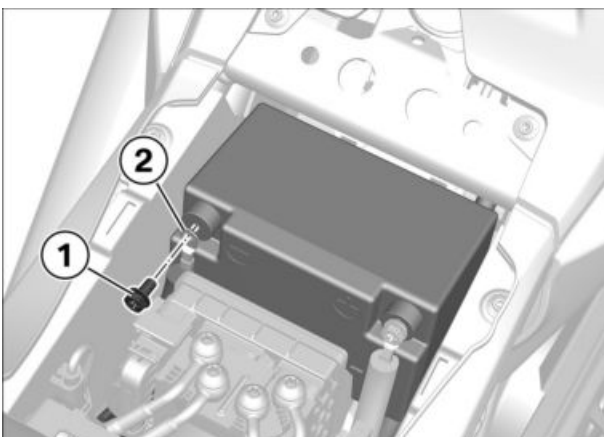

– with M Lightweight battery<sup>OE</sup> (053B)

- Remove screw **(1)** and remove wiring harness negative terminal **(2)** and insulate, for instance with adhesive tape.◇



# 5

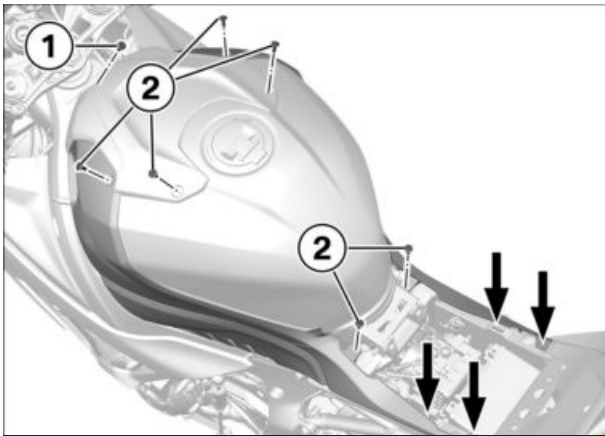

## ► Removing complete fuel-tank cover

- Remove bolt **(1)**.
- Remove screws **(2)**.
- Disengage the locators **(arrows)**.

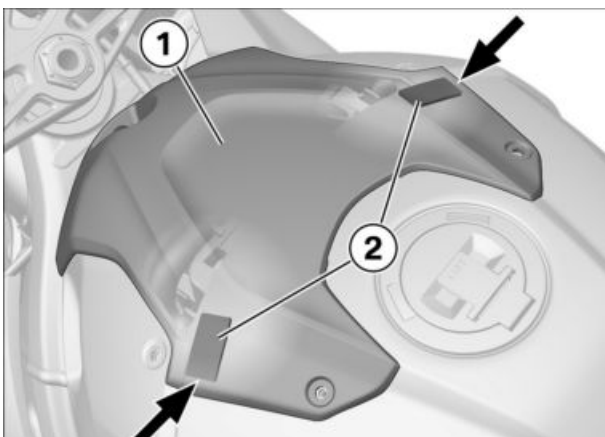

- Lift centre fuel-tank cover **(1)** at the edges **(arrows)** and release hook and loop tape **(2)**.

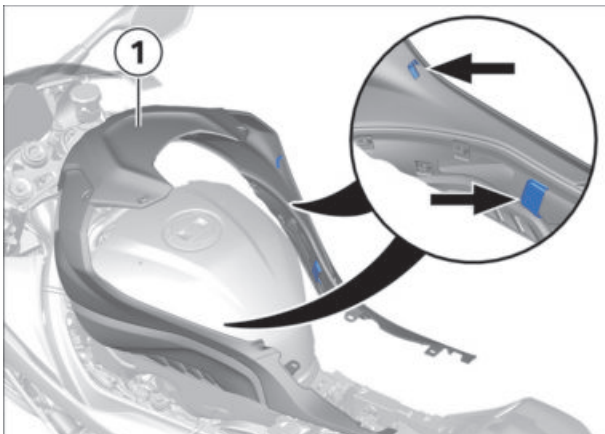

- Release fuel-tank cover **(1)** completely and detach locators **(arrows)**.
- Remove fuel-tank cover **(1)** completely.

# 6

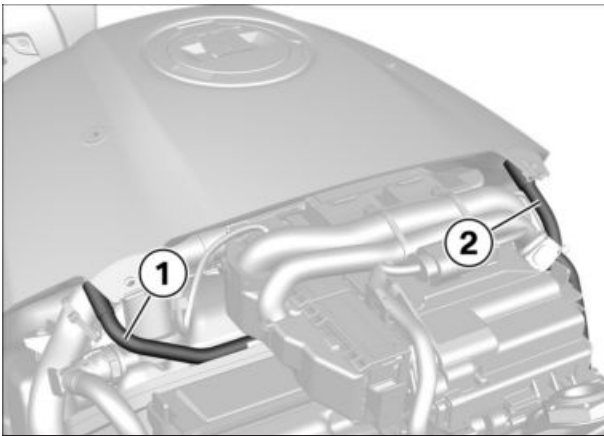

## ► Removing fuel tank

- Pull off hoses **(1)** and **(2)**.

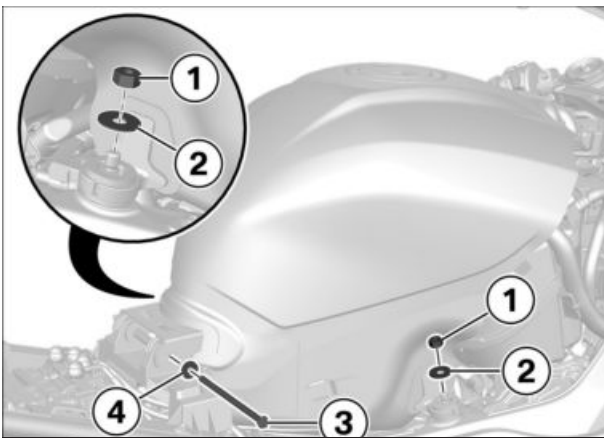

- Remove nuts **(1)** with washers **(2)**.
- Remove bolt **(3)** with washer **(4)**.

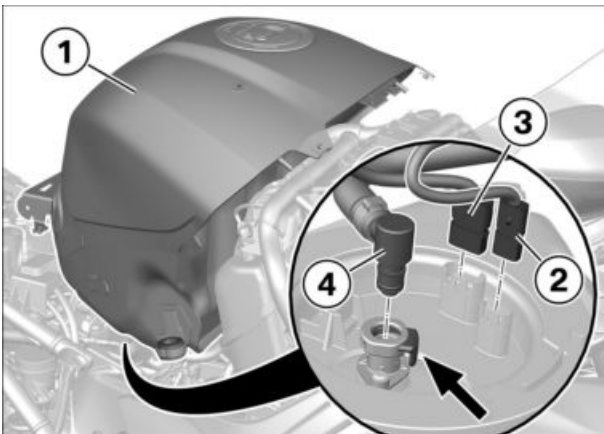

- Lift the fuel tank **(1)**.
- Disconnect plug connection **(3)** for electric fuel pump and plug connection **(2)** for fuel-level sensor.
- Press open the lock of the fuel delivery line **(arrow)** and disconnect fuel delivery line **(4)**.
- Remove fuel tank **(1)**.

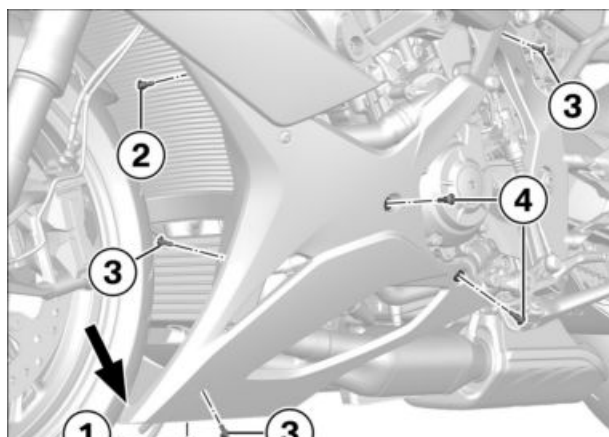

► **Removing fairing side panel with engine spoiler left and right**

- Remove bolt **(1)**.
- Remove bolt **(2)**.
- Remove screws **(3)**.
- Remove screws **(4)**.
- Unclip locator **(arrow)**.

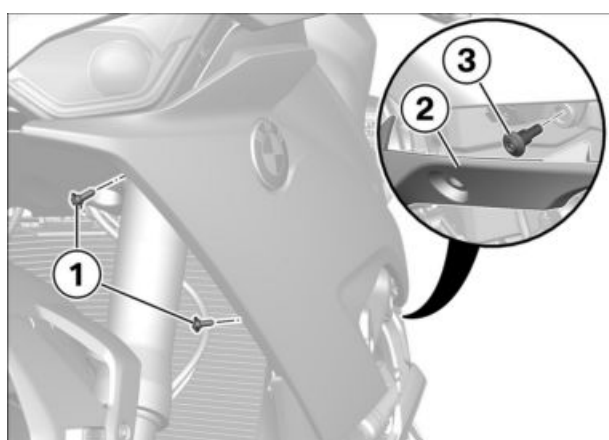

- Remove screws **(1)**.
- Release engine spoiler **(2)** and bend slightly down, remove bolt **(3)**.

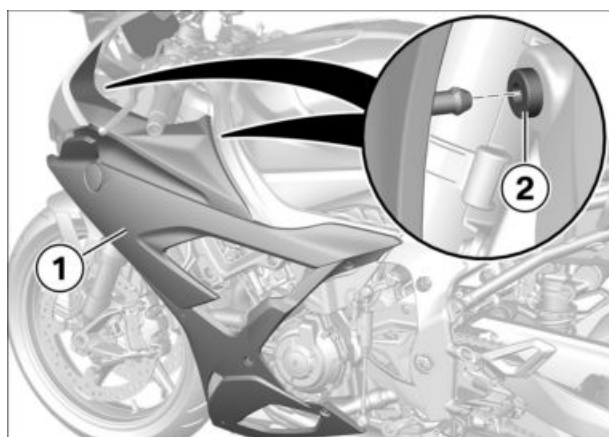

- Release fairing side panel **(1)** from grommets **(2)** and remove.

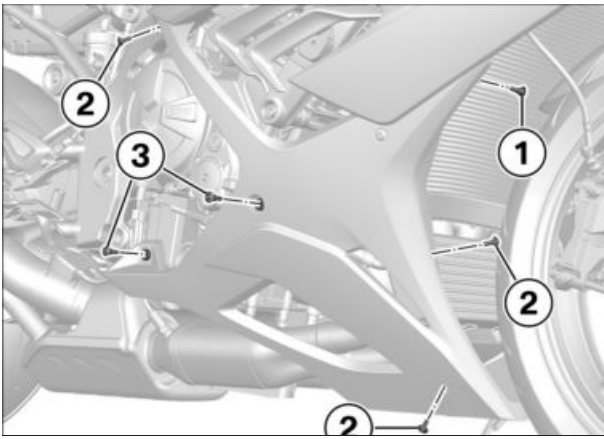

- Remove bolt **(1)**.
- Remove screws **(2)**.
- Remove screws **(3)**.

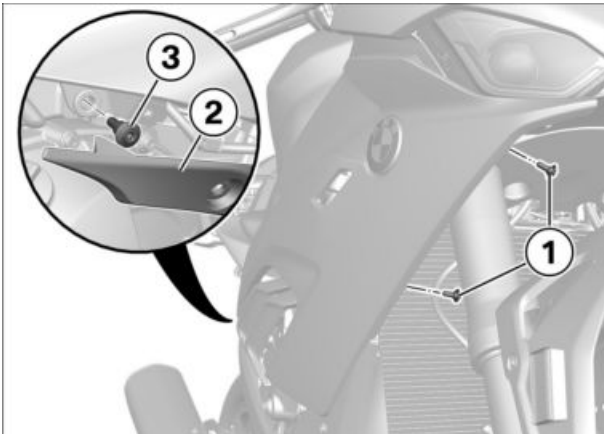

- Remove screws **(1)**.
- Release engine spoiler **(2)** and bend slightly down, remove bolt **(3)**.

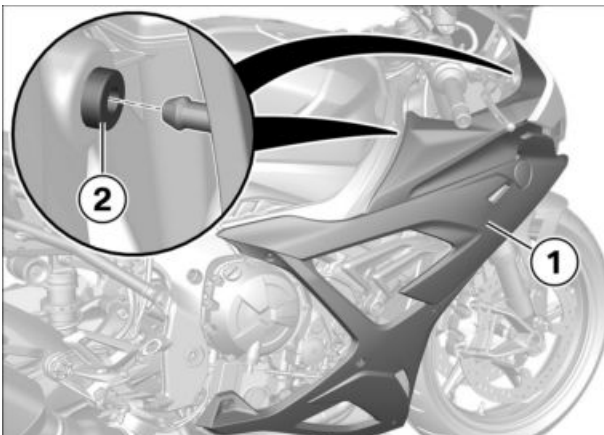

- Release fairing side panel **(1)** from grommets **(2)** and remove.



## 8

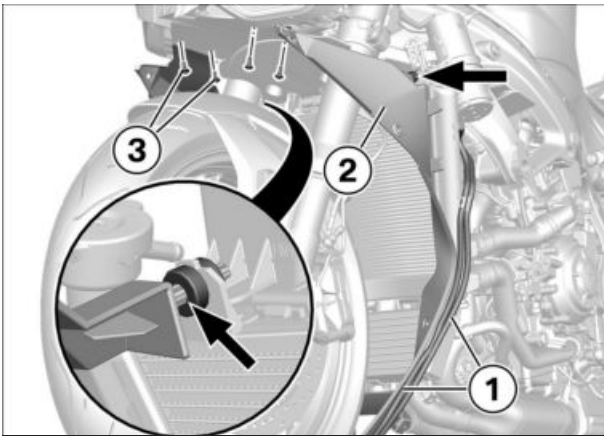

### ► Removing air deflector for radiator

- Release hoses **(1)** for tank ventilation from air duct **(2)**.
- Remove screws **(3)**.
- Release left and right air duct **(2)** from rubber grommets **(arrow)** and remove.



## 9

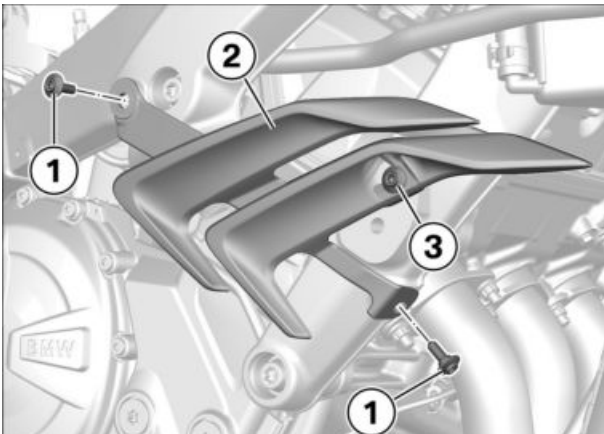

### ► Removing trim for right frame

- Remove screws **(1)**.
- Pull off trim **(2)** from the screw **(3)** to the front.



## 10

### ► Disengaging gear shift selector with Gear Shift Assistant

- Engage first gear.
- » Transmission is blocked for later slacking of the sprocket nut.

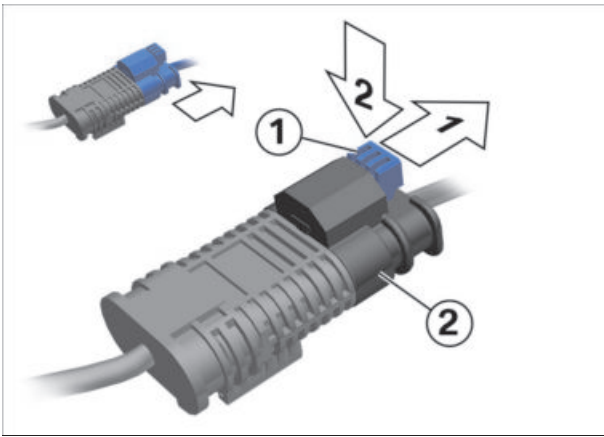

▷ **Information on disconnecting vibration-resistant plug**

**ATTENTION**

**Disconnection of the connector not in compliance with correct procedure**

Damage to locking tab

- Push the connector away from the locking tab, do not lift or bend the locking tab.
- Unlock locking tab **(1)** in direction of arrow **(arrow 1)**.
- Press down locking tab **(1)** in direction of arrow **(arrow 2)** and disconnect connector **(2)**.

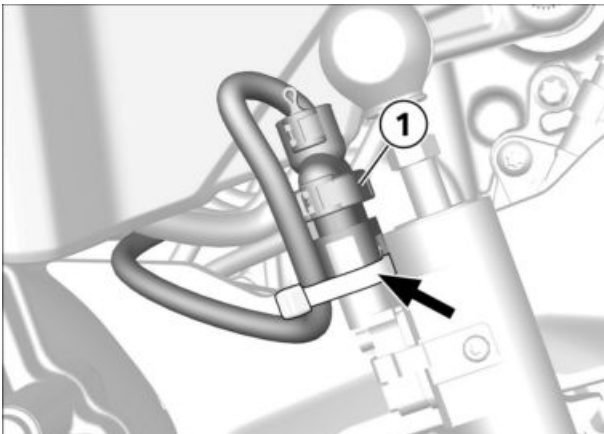

- Remove cable strap **(arrow)**.
- Unlock and disconnect connector **(1)** for Gear Shift Assistant.

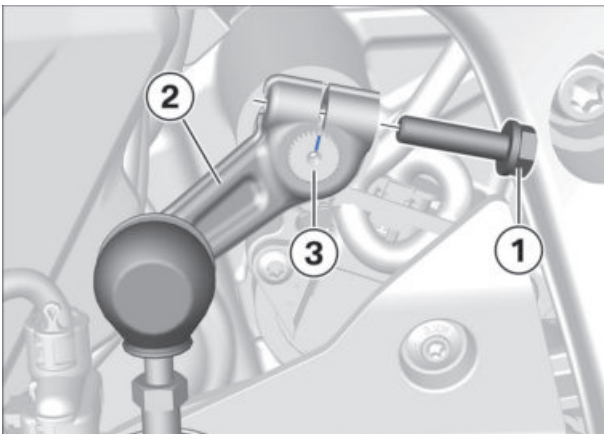

- Remove bolt **(1)**.
- Loosen gearshift lever **(2)** on gearshift shaft **(3)**.
- Place Gear Shift Assistant onto rider footrest.



# 11

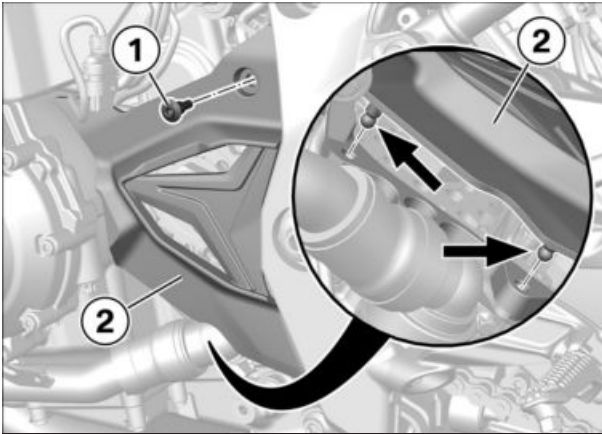

## ► Removing pinion cover

- Remove bolt (1).
- Slacken detent pins (arrows) evenly and remove pinion cover (2).



# 12

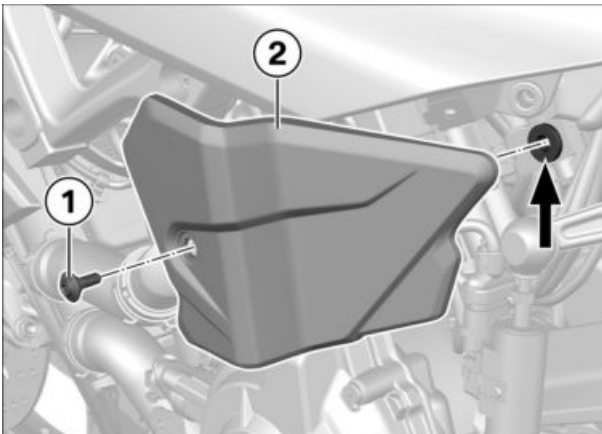

## ► Removing the trim of the relay

- Remove bolt (1).
- Remove trim (2) and also from rubber grommet (arrow).



# 13

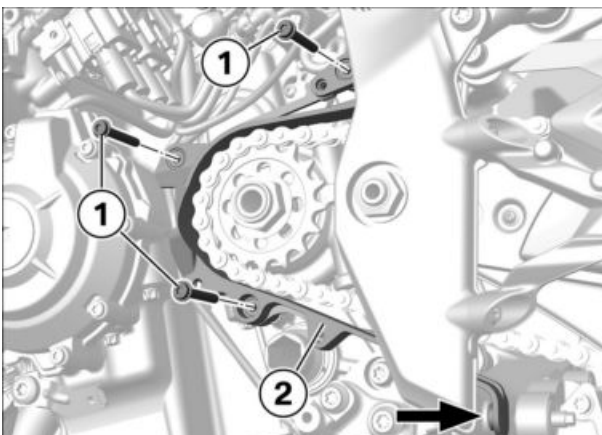

## ► Removing chain drop guard

- Remove screws (1).
- Unclip mounting (arrow) on the frame.
- Remove chain failure protection (2).



# 14

## ► Releasing pinion

### Requirement

Engage a low gear and apply the rear brake.

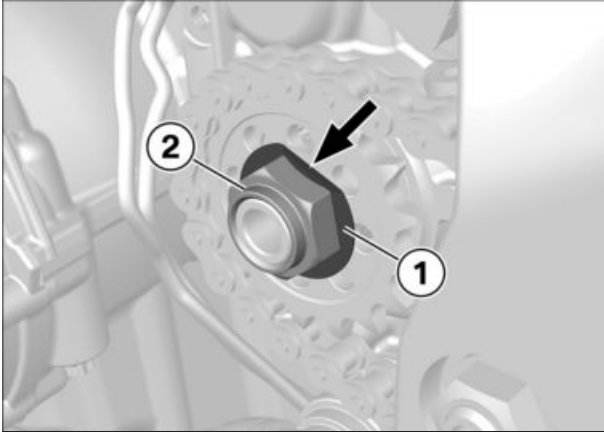

- Using a suitable tool, bend back the tab (**arrow**) on locking washer **(1)**.
- Loosen nut **(2)**.



# 15

## ► Loosen engine control unit with wiring harness

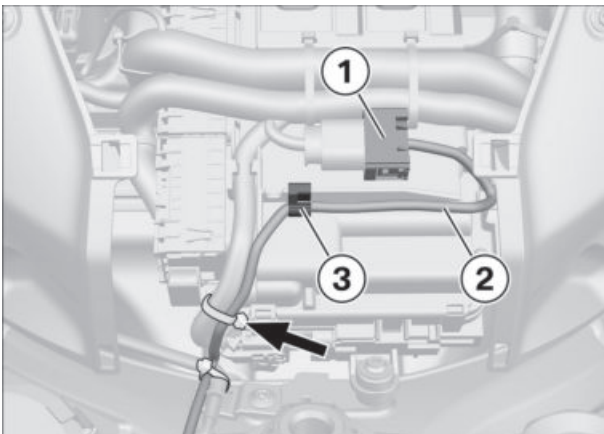

- Disconnect plug connection **(1)** for throttle grip.
- Loosen cable **(2)** from holder **(3)**.
- Remove cable strap (**arrow**).

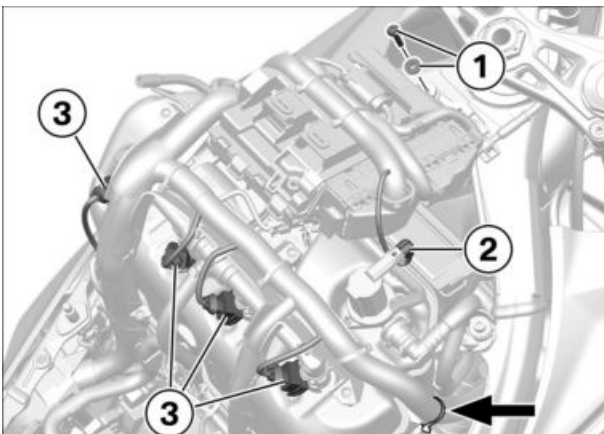

- Open the cable strap (**arrow**).
- Remove bolt with washer **(1)**.
- Disconnect connector **(2)** for secondary air control valve and connector **(3)** for fuel injectors.

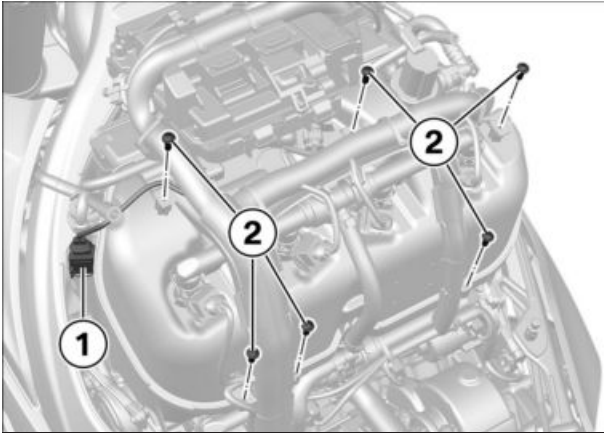

- Disconnect connector **(1)** for the tank vent valve.
- Remove screws **(2)**.

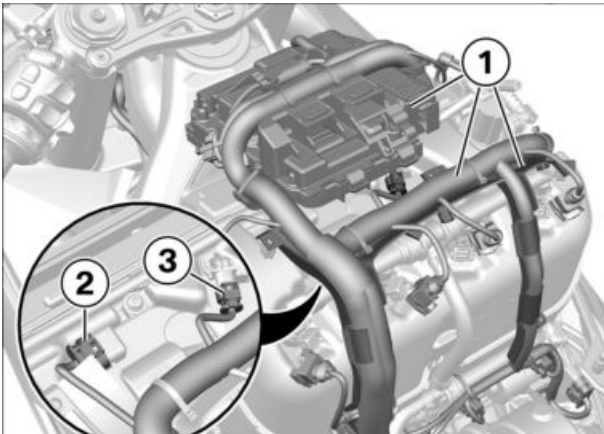

- Lift the control unit **(1)** with cable duct and wiring harness.
- Disconnect connector **(2)** for DISA servomotor.
- Disconnect connector **(3)** for the intake-air temperature sensor.
- Loosen control unit **(1)** with cable duct and wiring harness and place toward the rear.



## 16

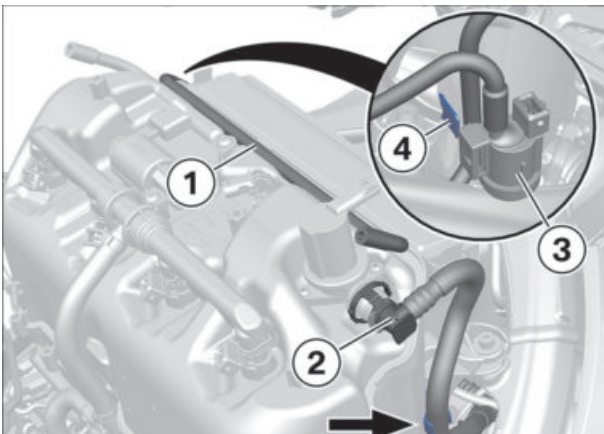

### ► Remove the intake air silencer

- Disconnect hose **(1)**.
- Unlock hose connection **(2)** for secondary air system, pull off and release hose from holder **(arrow)**.
- Release tank vent valve **(3)** from holder **(4)**.

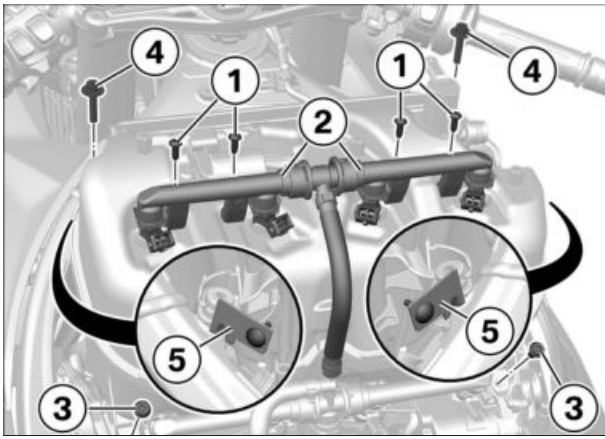

- Remove screws **(1)**.
- Loosen fuel injection pipe with injector nozzles **(2)**.
- Remove screws **(3)**.
- Remove screws **(4)** and holder **(5)**.

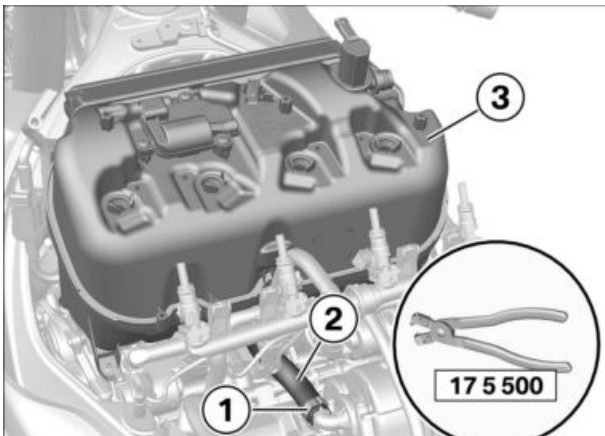

- Loosen clamp **(1)** with pliers (17 5 500) and pull off hose **(2)** for the crankcase ventilation.
- Lift intake silencer **(3)** and feed out hose **(2)** for crankcase ventilation.
- Remove intake silencer **(3)**.

## 17

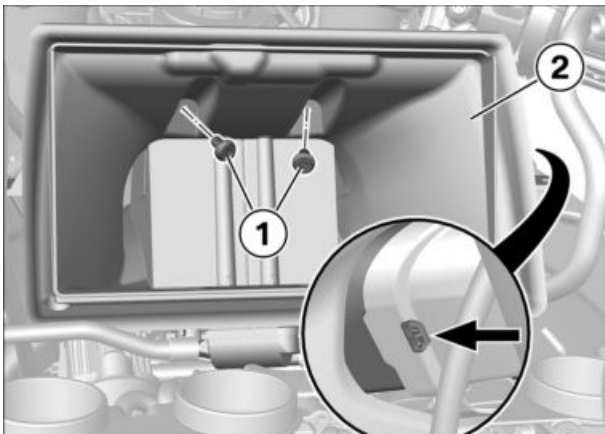

### ► Remove rear air intake duct

- Remove screws **(1)**.
- Loosen air intake duct **(2)**, loosen left and right fixtures **(arrow)** for this purpose.

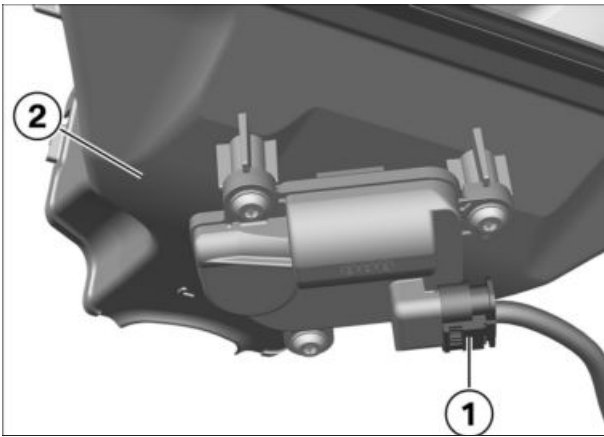

- Disconnect connector **(1)** and remove air intake duct **(2)**.

# 18

## ► Removing throttle-valve assembly

### NOTICE

Loosen the throttle-valve assembly first, then disconnect connectors; otherwise, there is a risk of damaging the connectors.

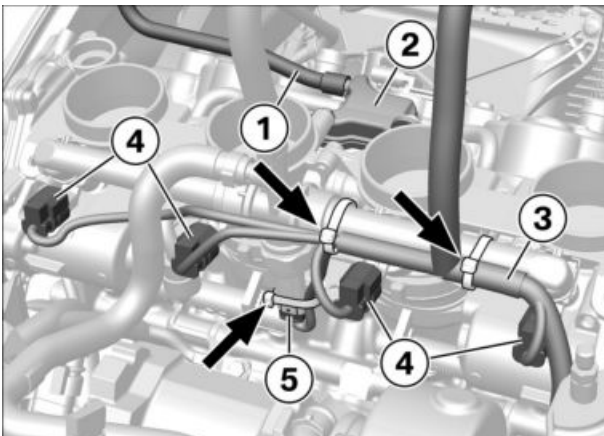

- Pull hose **(1)** off distributor ignition **(2)**.
- Open cable straps **(arrows)**.
- Release wiring harness **(3)**.
- Disconnect connector **(4)** for fuel injectors.
- Disconnect connector **(5)** for fuel pressure sensor.

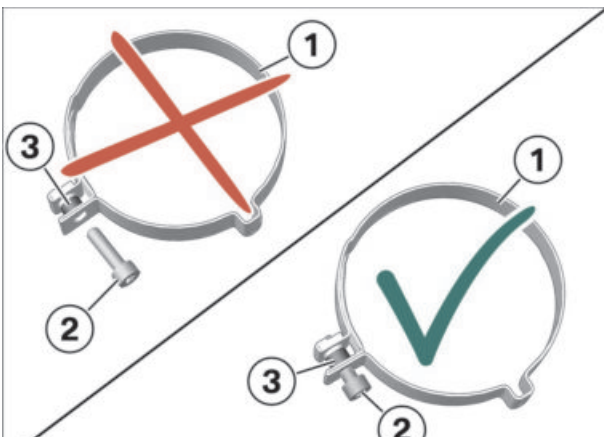

- While loosening screw clamps **(1)** of the throttle valve assembly, the bolt **(2)** must not be unscrewed too far or removed.
- » The spacer **(3)** must not fall out.

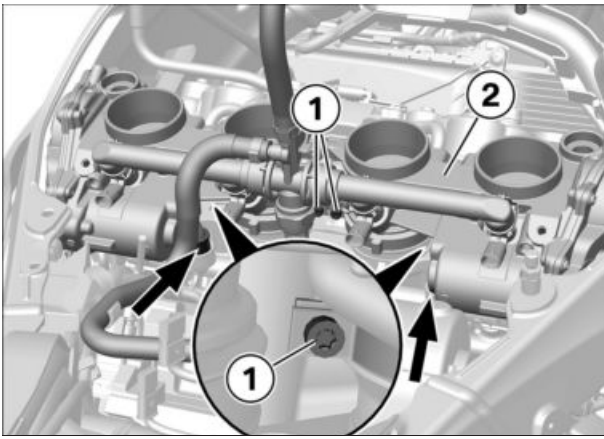

- Loosen screw clamps **(1)**.
- Release throttle valve assembly **(2)** taking care of connections **(arrows)** for bypass lines.

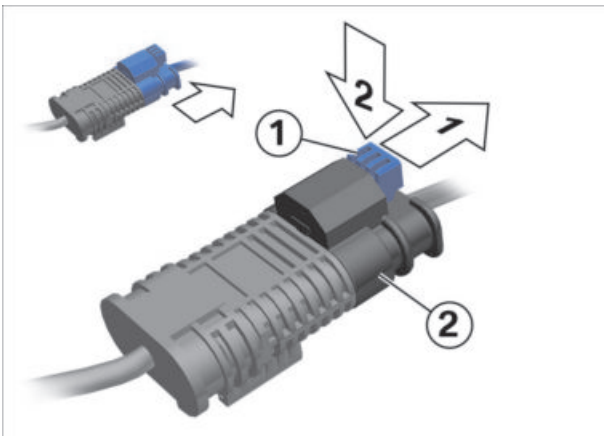

▷ **Information on disconnecting vibration-resistant plug**

**ATTENTION**

**Disconnection of the connector not in compliance with correct procedure**

Damage to locking tab

- Push the connector away from the locking tab, do not lift or bend the locking tab.

- Unlock locking tab **(1)** in direction of arrow **(arrow 1)**.
- Press down locking tab **(1)** in direction of arrow **(arrow 2)** and disconnect connector **(2)**.

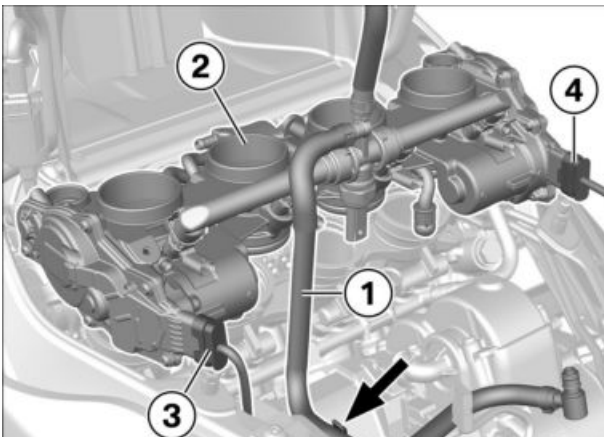

◁

- Release fuel line **(1)** from holder **(arrow)**.
- Lift throttle valve assembly **(2)** and disconnect connectors **(3)** and **(4)**.
- Remove throttle-valve assembly **(2)**.
- Seal the intake ducts at the engine.

◀

# 19

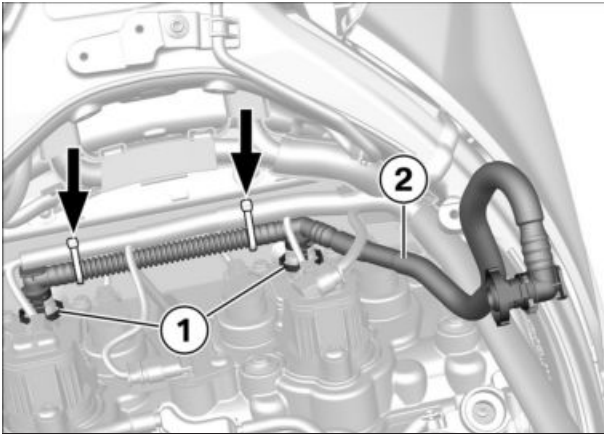

## ► Removing secondary air system line

- Remove the cable straps (**arrows**).
- Unlock and pull off the hose connection (**1**), thread out and remove the secondary air system-line (**2**).



# 20

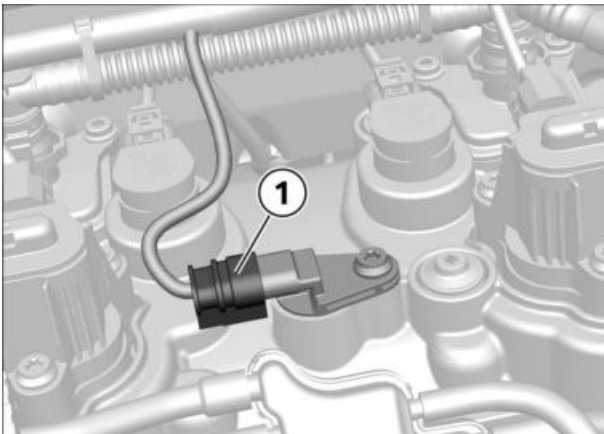

## ► Disconnecting engine wiring harness from cylinder head cover

- Disconnect connector for switching cam sensor (**1**).

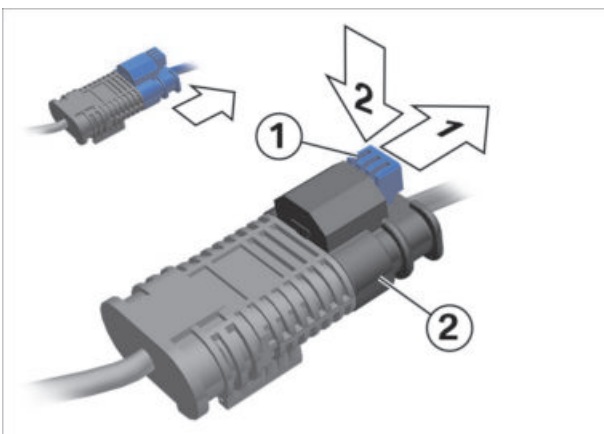

## ▷ Information on disconnecting vibration-resistant plug

### **ATTENTION**

#### **Disconnection of the connector not in compliance with correct procedure**

Damage to locking tab

- Push the connector away from the locking tab, do not lift or bend the locking tab.

- Unlock locking tab (**1**) in direction of arrow (**arrow 1**).
- Press down locking tab (**1**) in direction of arrow (**arrow 2**) and disconnect connector (**2**).



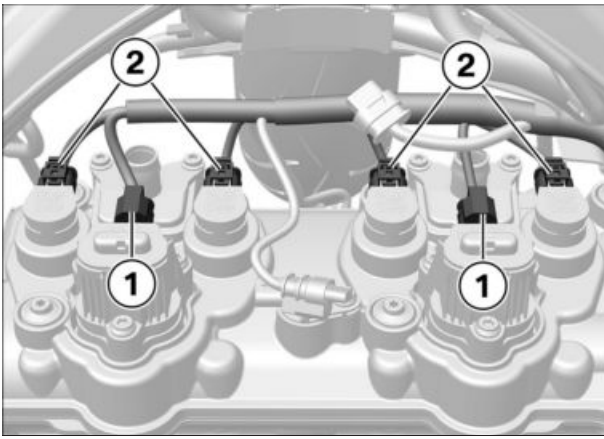

- Disconnect connectors **(1)** for switching cam adjusters.
- Disconnect connector **(2)** for direct ignition coils.

## 21

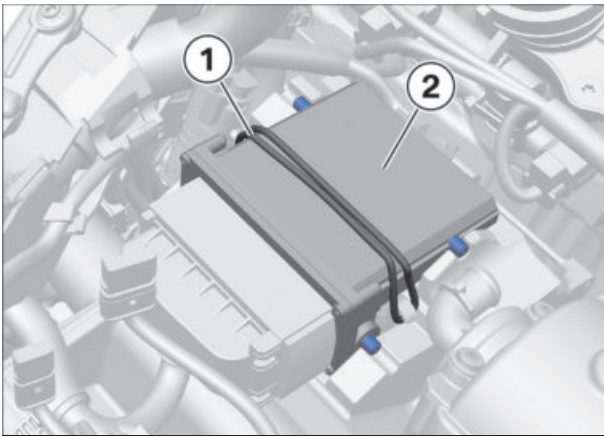

– with Dynamic Damping Control (DDC)<sup>OE</sup> (0223)

### ► Disengaging control unit for electronic suspension adjustment

- Remove O-ring **(1)**.
- Release control unit **(2)** and hang to one side.◊

## 22

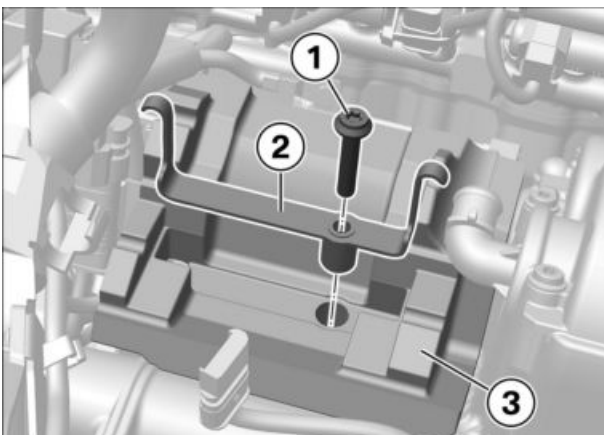

### ► Disconnecting starter motor

- Remove bolt **(1)**.
- Remove retaining bracket **(2)** and holder **(3)**.

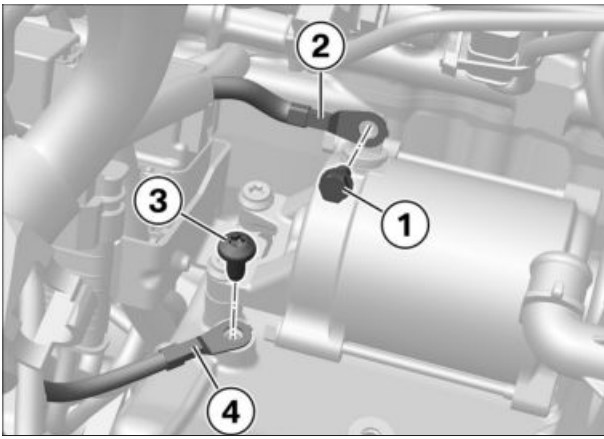

- Remove bolt **(1)** and release positive wire for starter motor **(2)**.
- Remove bolt **(3)**, release grounding cable **(4)**.

## 23

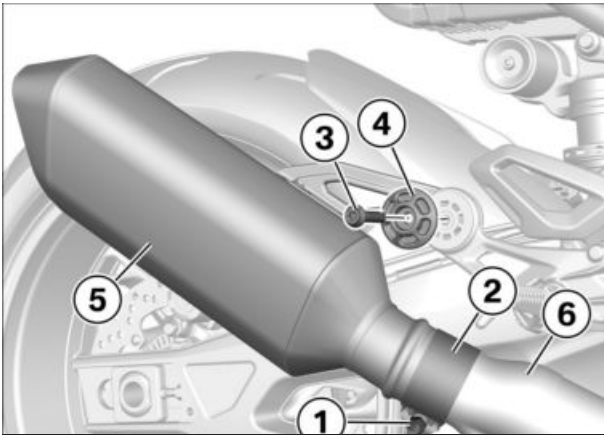

### ► Removing silencer

- Slacken nut **(1)** and release clamp **(2)**.
- Remove bolts **(3)** and shaped washer **(4)**.
- Remove the silencer **(5)** from the front silencer **(6)**.

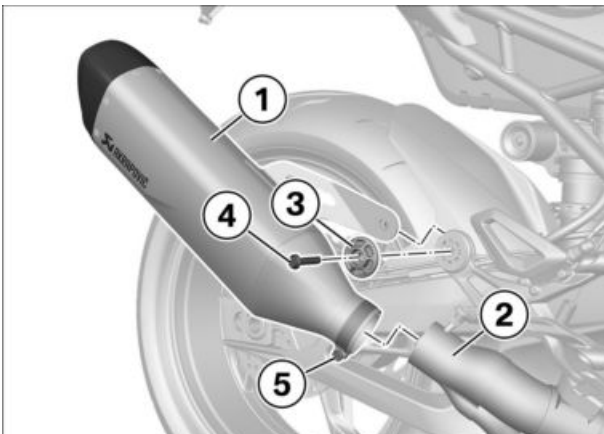

– with M titanium exhaust system<sup>OE</sup> (019H)

or

– with M Sports silencer<sup>OE</sup> (019G)

- Open clamping collar **(5)**.
- Remove bolts **(4)** and shaped washer **(3)**.
- Remove the silencer **(1)** from the front silencer **(2)**.◇

## 24

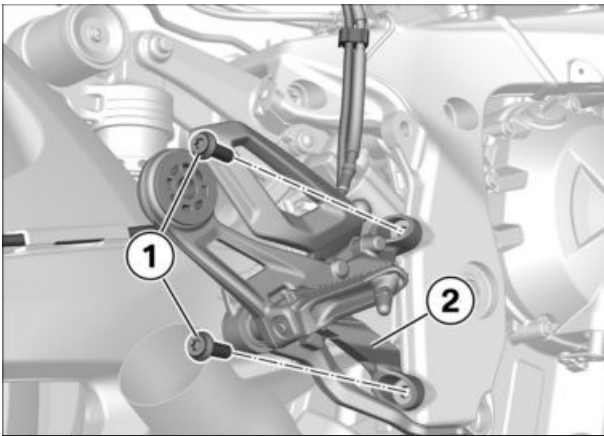

### ► Releasing right footrest plate

- Remove bolts (1) and loosen footrest plate (2).



## 25

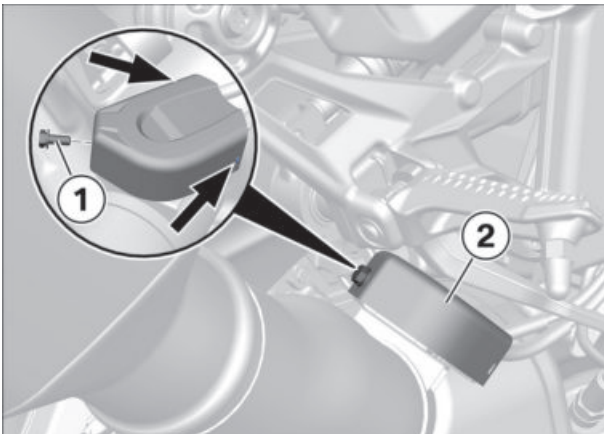

### ► Removing cover of exhaust-flow control valve

- Remove screw (1) and remove cover (2) from fixtures (arrows).

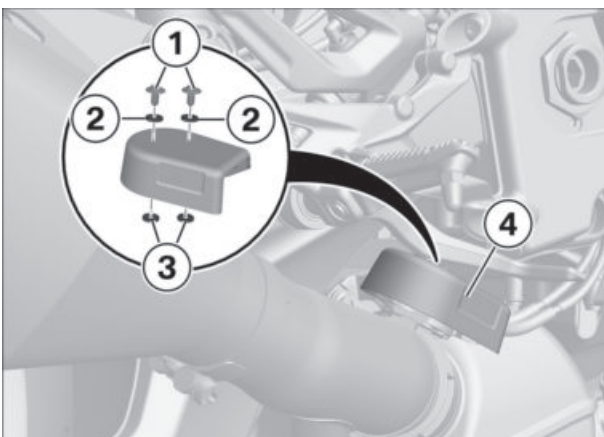

– with M titanium exhaust system<sup>OE</sup> (019H)

- Remove screws (1) with contact discs (2).
- Remove cover (4), checking shims (3).◇



## 26

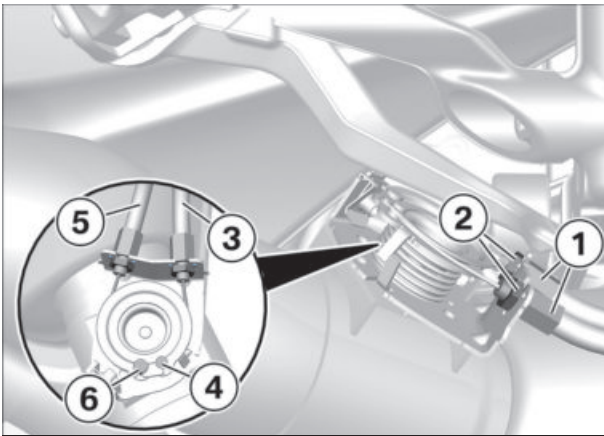

### ► Disengaging Bowden cables from exhaust-flow control valve

- Slacken screws **(1)** and counter-hold nuts **(2)** where needed.
- Loosen return cable **(3)** and detach cable **(4)**.
- Loosen actuating cable **(5)** and detach cable **(6)**.

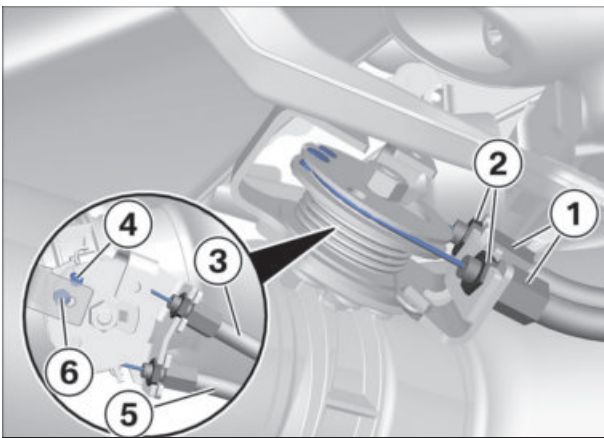

– with M titanium exhaust system<sup>OE</sup> (019H)

- Slacken screws **(1)** and counter-hold nuts **(2)** where needed.
- Loosen return cable **(3)** and detach cable **(4)**.
- Loosen actuating cable **(5)** and detach cable **(6)**.<

## 27

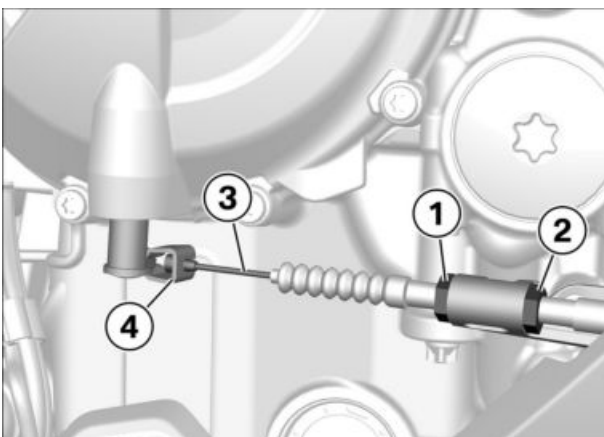

### ► Disengaging clutch cable

- Slacken adjusting nuts **(1)** and turn all the way forward.
- Back off adjusting nut **(2)** completely.
- Detach and remove clutch cable **(3)** from lever **(4)**.

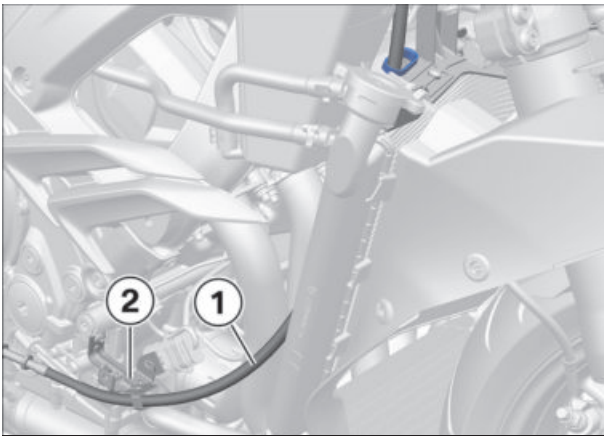

- Loosen clutch cable (1) from holder (2).

## 28

### ► Releasing rear exhaust manifold

#### ⚠ CAUTION

##### Hot exhaust system

Risk of burn injury

- Do not touch a hot exhaust system.

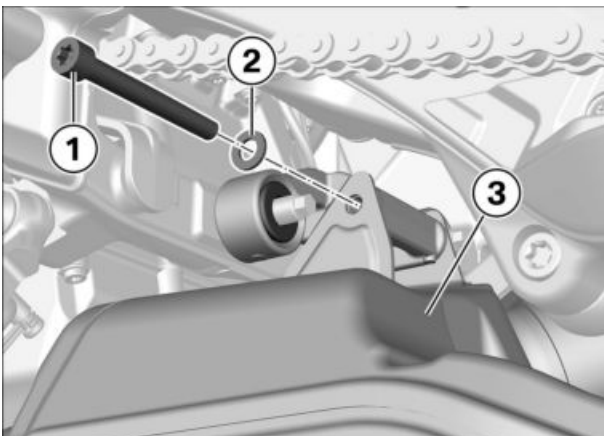

- Remove bolt (1) and washer (2) from exhaust manifold (3).

## 29

### ► Relieving chain tension

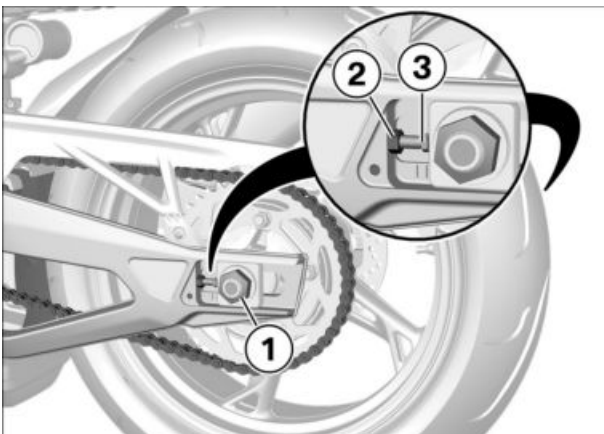

- Loosen nut (1).
- Release lock nuts (2) on left and right.
- Slacken drive chain with tensioning screws (3) on left and right.

## 30

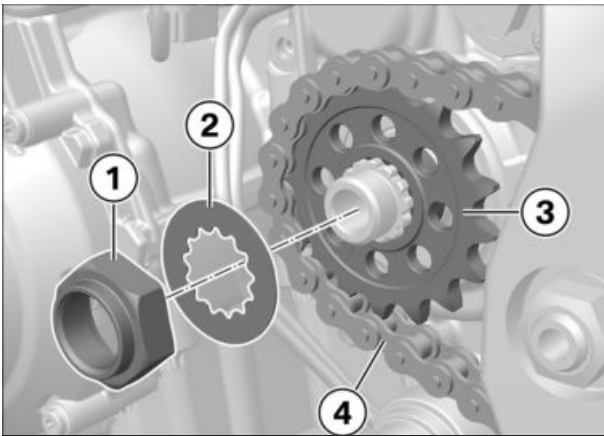

### ► Removing pinion

- Remove nut (1) and locking washer (2).
- Work pinion (3) free from drive chain (4) and remove.

## 31

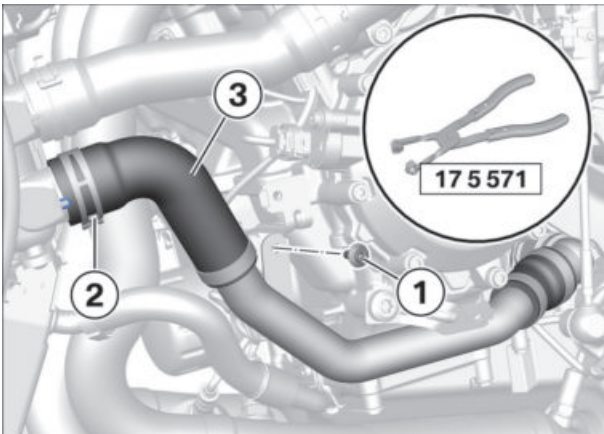

### ► Draining coolant

- Place a suitable container in position.
- Remove bolt (1).
- Release clamp (2) with pliers (17 5 571).
- Pull off coolant hose (3), push down and catch emerging coolant.

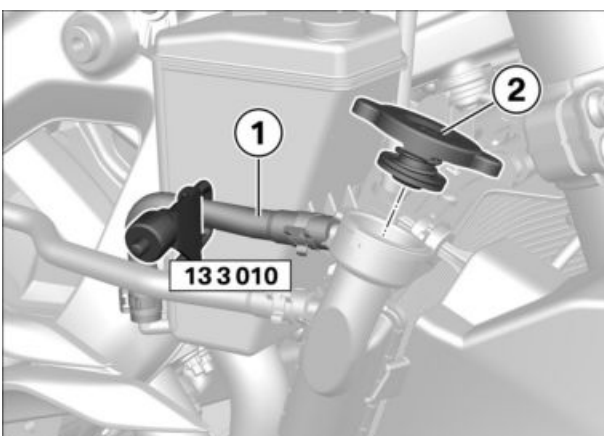

### ▷ Removing radiator cap

- Seal off overflow hose (1) with hose clip (13 3 010).
- Remove radiator cap (2).

- ◁ Drain the coolant from the radiator and the lines.

32

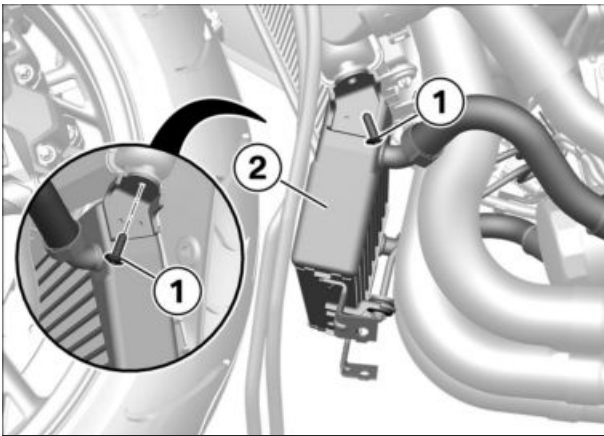

► **Releasing oil cooler**

- Remove screws **(1)**.
- Release oil cooler **(2)**.



33

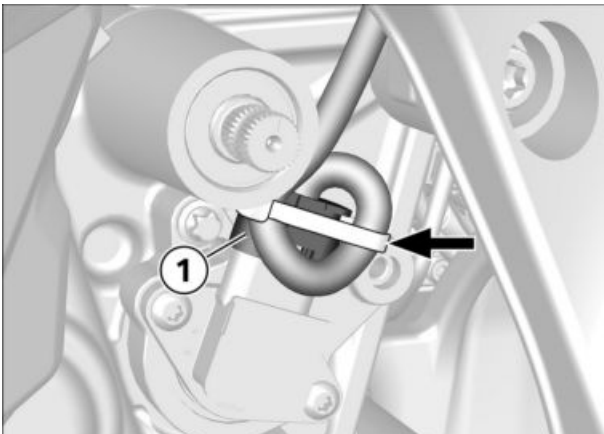

► **Releasing engine wiring harness**

- Remove cable strap **(arrow)**.
- Unlock and disconnect connector **(1)** for transmission potentiometer.

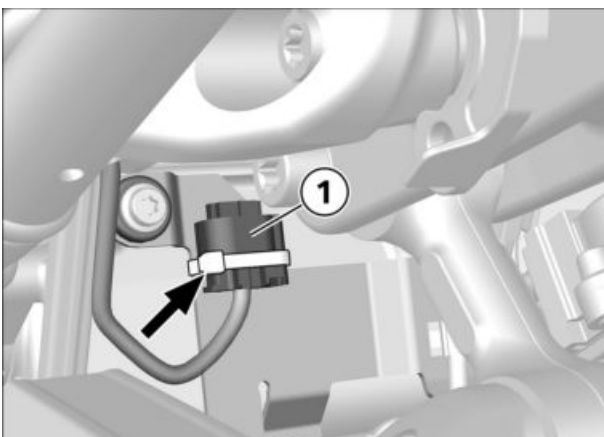

- Remove cable strap **(arrow)** and disconnect the connector **(1)**.

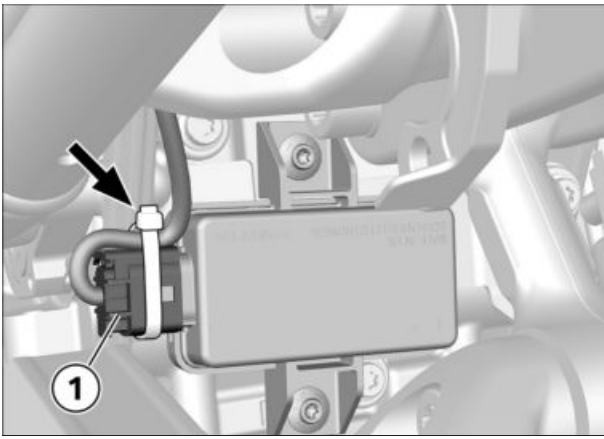

- with tyre pressure control (RDC)<sup>OE</sup> (0530)
- Remove cable strap (**arrow**).
- Disconnect connector **(1)** for RDC control unit.◊

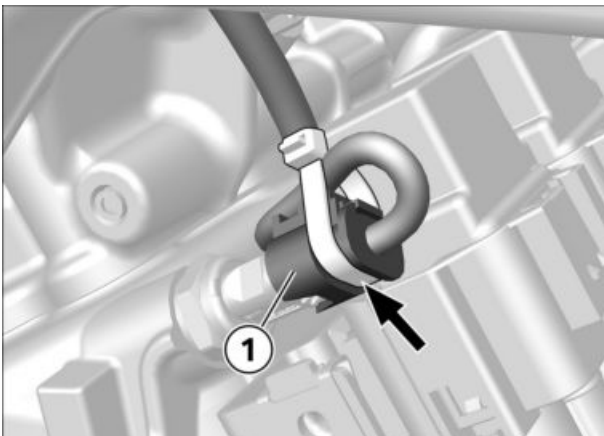

- Remove cable strap (**arrow**).
- Disconnect connector **(1)** for coolant temperature sensor.

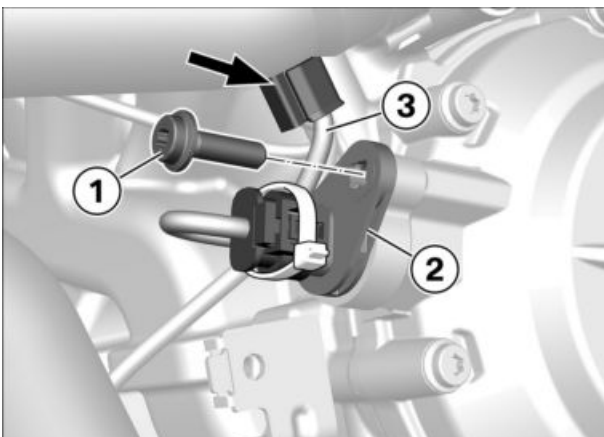

- Remove bolt **(1)**.
- Release crankshaft sensor **(2)** and hang to one side.
- Release the cable **(3)** from the holder (**arrow**).

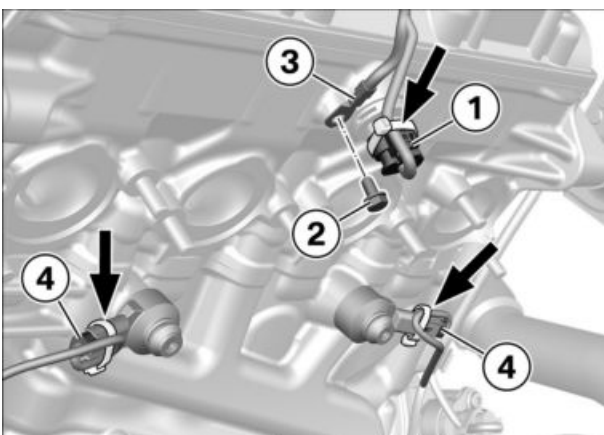

- Remove the cable strap (**arrows**).
- Disconnect connector **(1)** for camshaft sensor.
- Remove bolt **(2)** and release ground connection **(3)**.
- Disconnect connectors for knock sensors **(4)**.

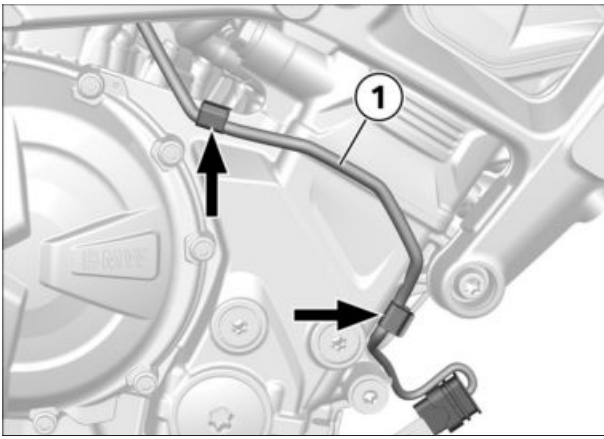

- Release wiring harness **(1)** from holders **(arrows)**.

## 34

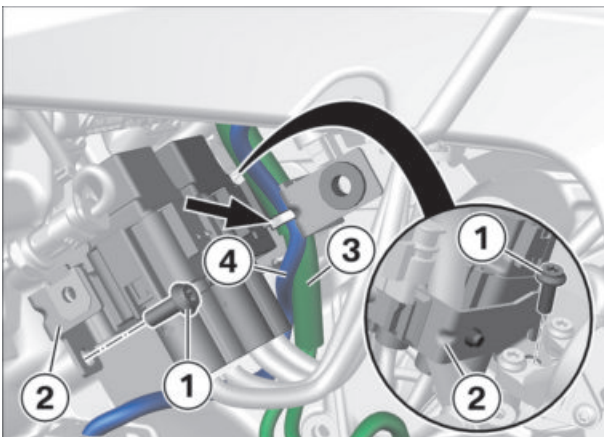

### ► Releasing relay holder

- Remove cable strap **(arrow)**.
- Remove screws **(1)**.
- Release relay holder **(2)** with relay and hang to the side releasing wiring harness **(3)** for Gear Shift Assistant and side-stand switch and cable **(4)** for alternator.

## 35

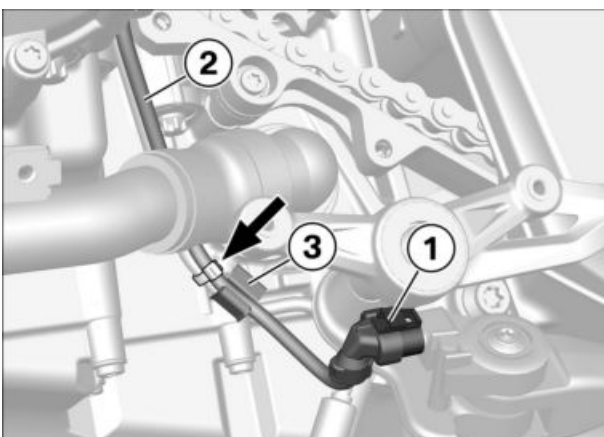

### ► Disconnecting connector for side-stand switch

- Disconnect connector **(1)** for side-stand switch.
- Loosen cable **(2)** from holder **(3)**.
- Remove cable strap **(arrow)**.

### ► Releasing cable for voltage regulator

#### ATTENTION

##### Use of hard or sharp-edged objects in proximity to component

Component damage

- Take care not to scratch components; cover or mask as necessary.

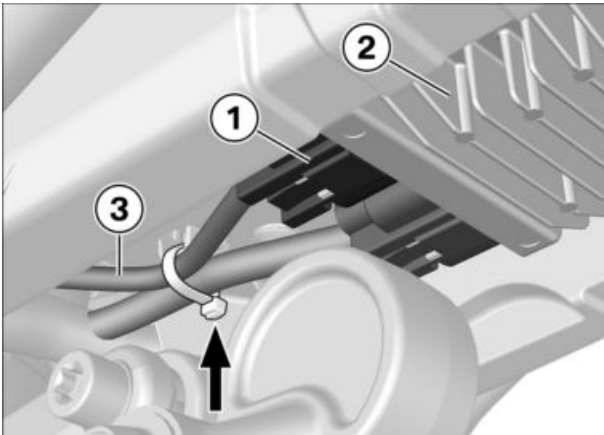

- Remove cable strap (**arrow**).
- Disconnect connector (**1**) from voltage regulator (**2**).
- Work connector (**1**) with cable (**3**) for alternator through to the front.

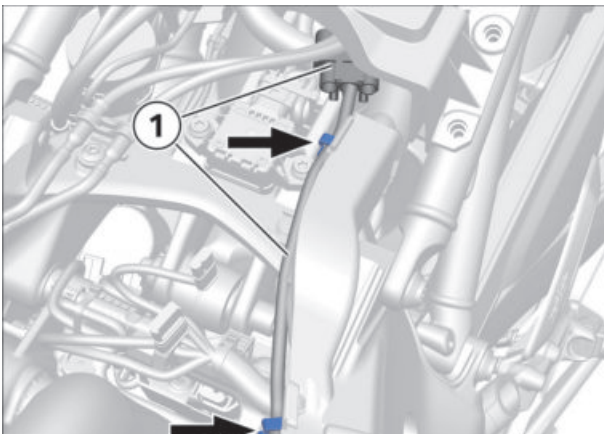

- Thread cable (**1**) for alternator to the front and release from holders (**arrows**) and from frame.

► **Disconnecting oxygen sensors**

▷ **Information on disconnecting vibration-resistant plug**

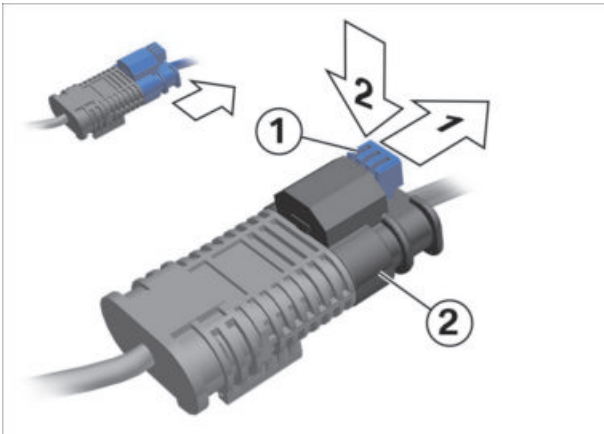

**ATTENTION**

**Disconnection of the connector not in compliance with correct procedure**

Damage to locking tab

- Push the connector away from the locking tab, do not lift or bend the locking tab.

- Unlock locking tab **(1)** in direction of arrow **(arrow 1)**.
- Press down locking tab **(1)** in direction of arrow **(arrow 2)** and disconnect connector **(2)**.

◁

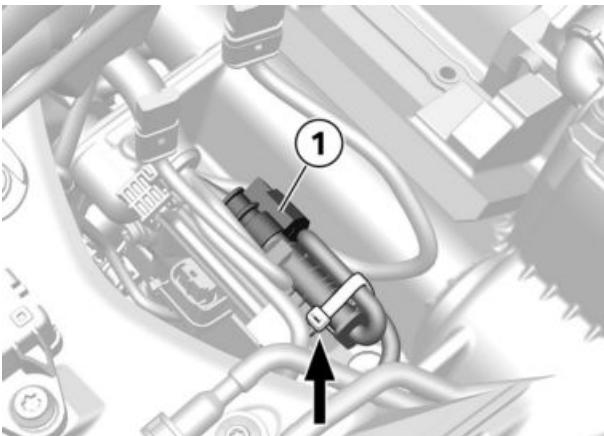

- Remove cable strap **(arrow)**.
- Disconnect plug connection **(1)** for monitoring oxygen sensor.

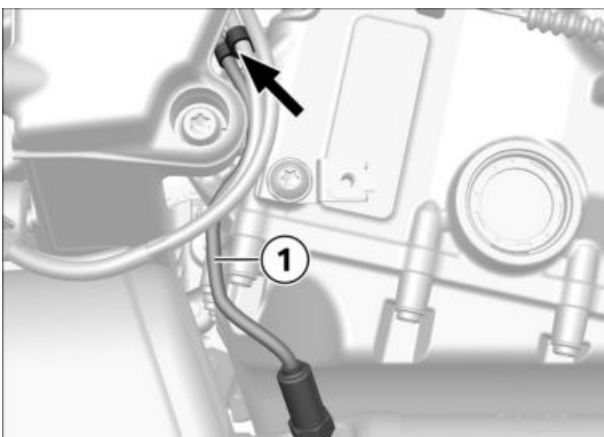

- Release the cable **(1)** for the monitoring oxygen sensor from the holder **(arrow)**.

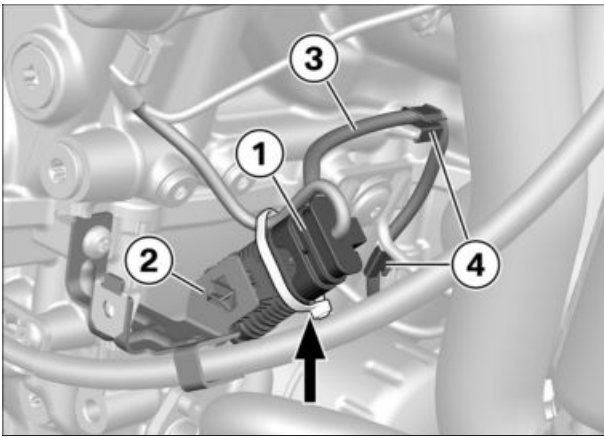

- Release plug connection **(1)** for front oxygen sensor from holder **(2)**.
- Remove cable strap **(arrow)**.
- Disconnect plug connection **(1)** for right front oxygen sensor.
- Release and guide out cable **(3)** from holder **(4)**.

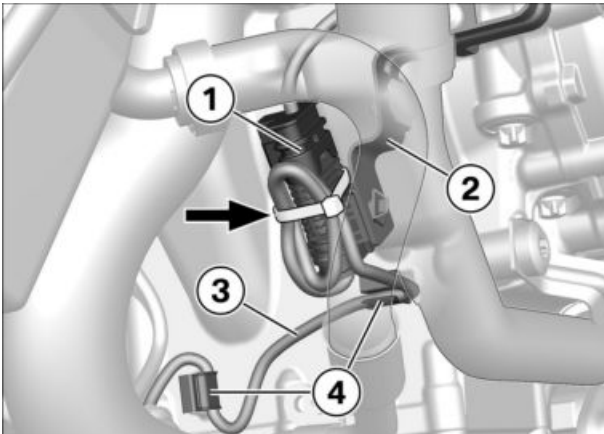

- Release plug connection **(1)** for left front oxygen sensor from holder **(2)**.
- Remove cable strap **(arrow)**.
- Disconnect plug connection **(1)** for left front oxygen sensor.
- Release and guide out cable **(3)** from holder **(4)**.

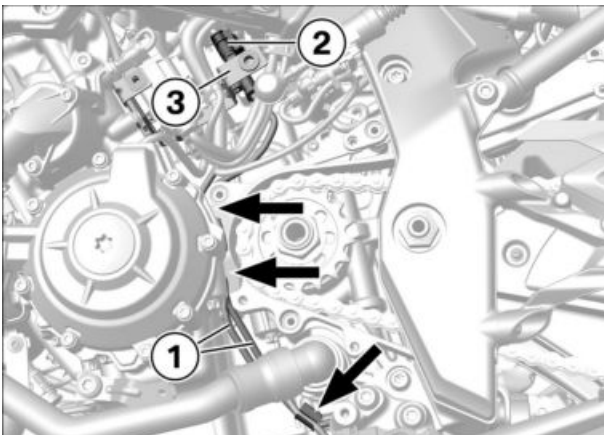

- Release cable **(1)** for left monitoring oxygen sensor and side-stand switch from holders **(arrows)**.
- Release plug connection **(2)** for left monitoring oxygen sensor and work clear from relay holder **(3)** outward.
- Disconnect plug connection **(2)** for left monitoring oxygen sensor.

# 38

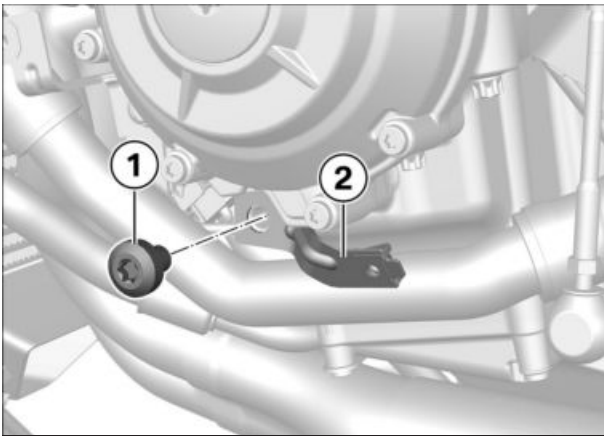

## ► Removing bracket for engine spoiler on right and left

- Remove bolt **(1)** and remove bracket **(2)**.

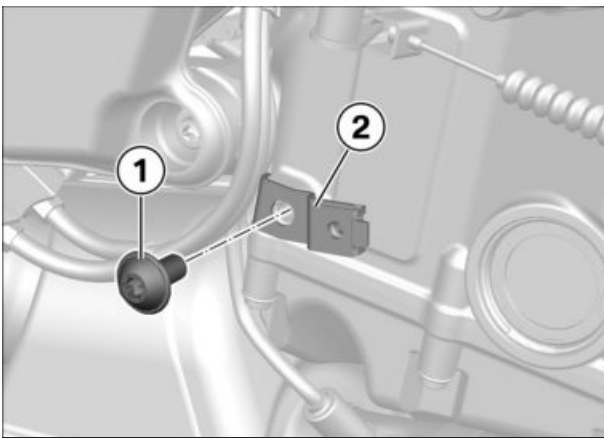

- Remove bolt **(1)** and remove bracket **(2)**.

# 39

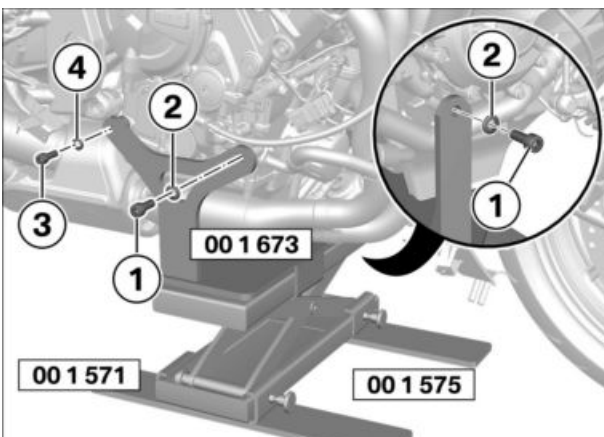

## ► Installing engine lifter

### **ATTENTION**

#### **Vehicle toppling to side**

Risk of damage to parts if vehicle topples

- Make sure that the vehicle is secured so that it cannot topple sideways.

- Secure extensions (00 1 575) to scissor-type lifter (00 1 571).
- Secure engine fixture (00 1 673) with included bolts **(1)** with washers **(2)** and bolt **(3)** with washer **(4)** on the engine.
- Raise scissor-type lifter (00 1 571) and install in engine fixture (00 1 673), making sure that engine fixture (00 1 673) is positioned centrally on scissor-type lifter (00 1 571).
- Raise the engine lifter until the motorcycle is standing firmly.

## ► Remove the engine

### ATTENTION

#### Use of hard or sharp-edged objects in proximity to component

Component damage

- Take care not to scratch components; cover or mask as necessary.

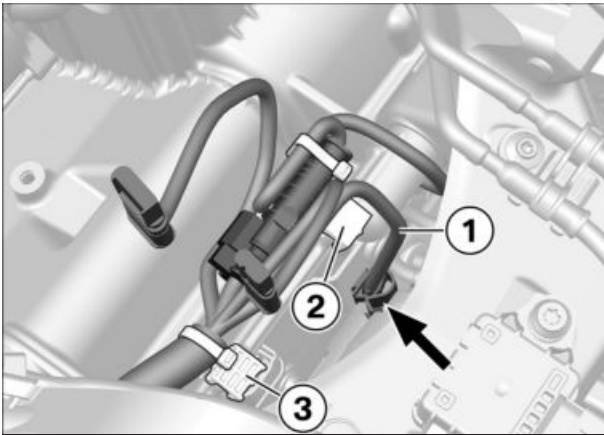

- Release the cable **(1)** for the servomotor for exhaust flap from the holder **(arrow)**.
- Release cable clip **(2)** and **(3)** with wiring harness from crankcase.

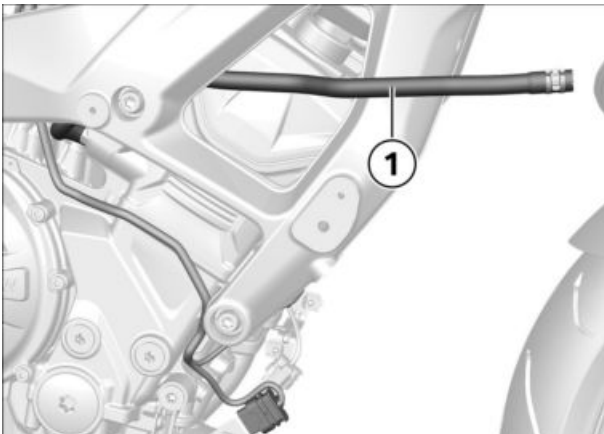

- Thread coolant venting hose **(1)** through frame to the inside and place onto engine.

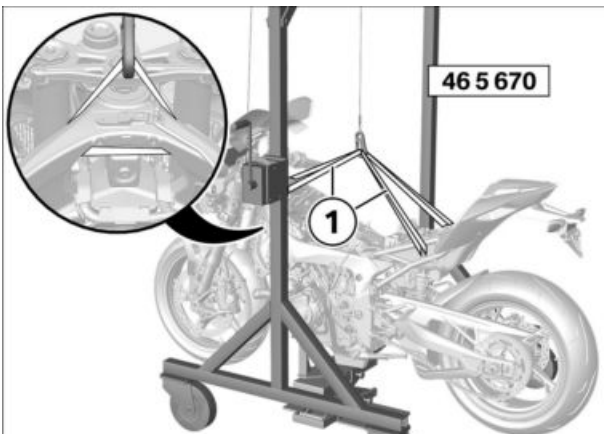

- Use straps **(1)** to secure the motorcycle to assembly crane (46 5 670).
- Secure the straps to the rear frame and the main frame, **not** to the handlebars.

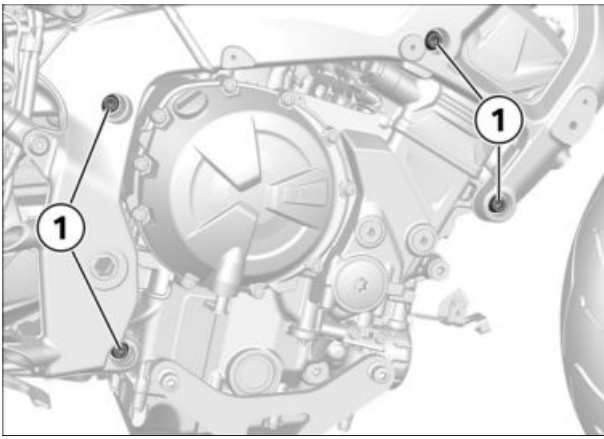

- Loosen screws **(1)**.

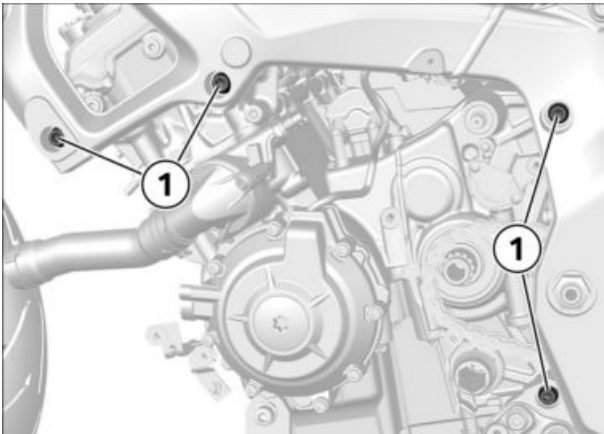

- Loosen screws **(1)**.

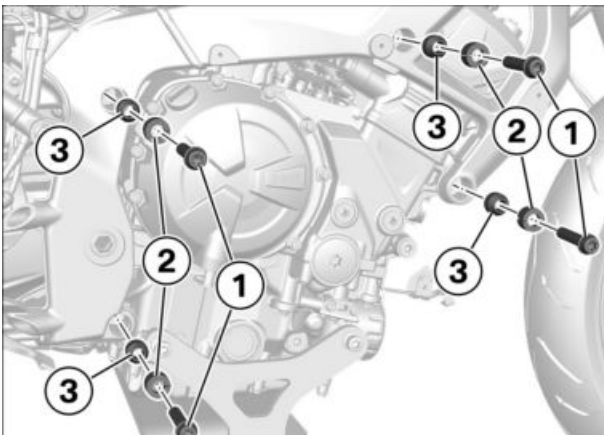

- Remove screws **(1)** with expander elements **(2)** and taper elements **(3)**.

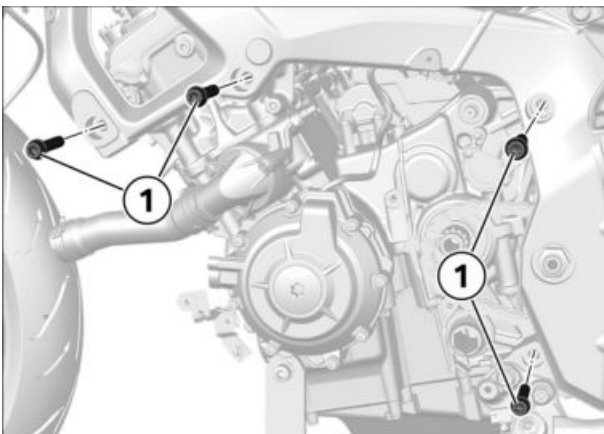

- Remove screws **(1)**.

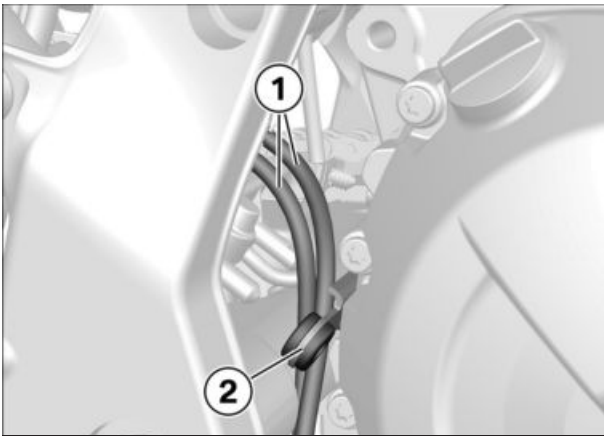

- Lower engine with engine lifter and slide it to the front.
- Feed out Bowden cables **(1)** for exhaust flap on holder **(2)**.

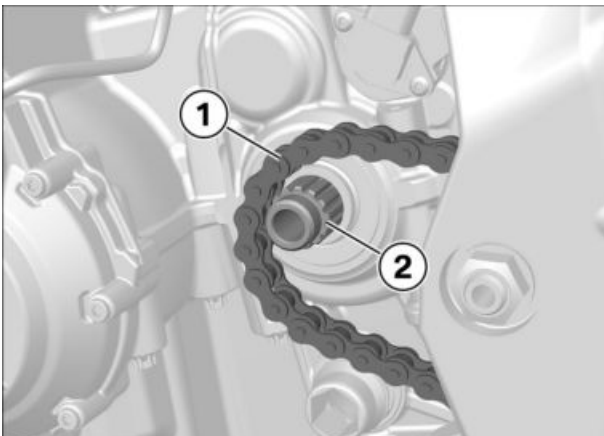

- Position engine with engine lifter so that the drive chain **(1)** of the transmission output shaft can be threaded out.
- Thread out the drive chain **(1)** from the transmission output shaft **(2)**.

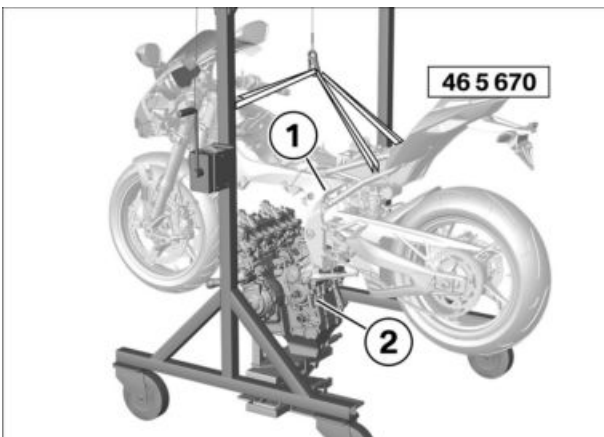

- Lift motorcycle **(1)** with assembly crane (46 5 670) and roll it away, noting engine **(2)**.

# 41

## ► Releasing exhaust manifold

### **⚠ CAUTION**

#### **Hot exhaust system**

Risk of burn injury

- Do not touch a hot exhaust system.

## NOTICE

Support the exhaust system to make it easier to remove and install the assembly.

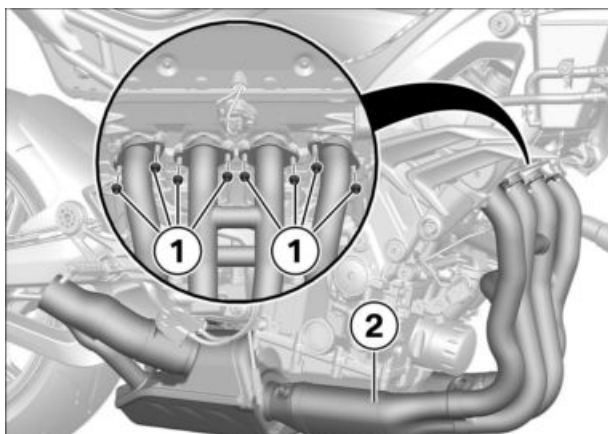

- Remove nuts **(1)**.
- Lower exhaust manifold **(2)**.
- » Exhaust manifold released from cylinder head.

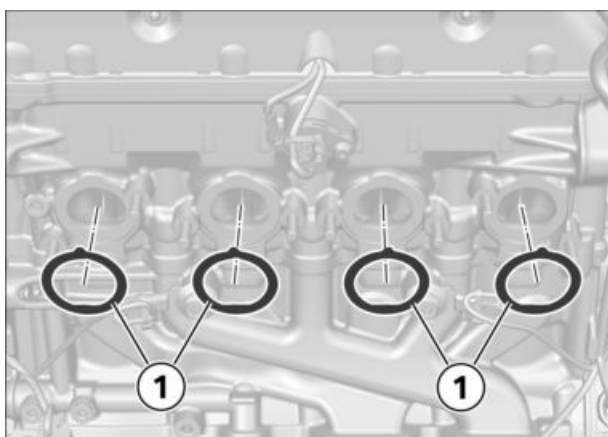

- Remove exhaust manifold seals **(1)**.

## 42

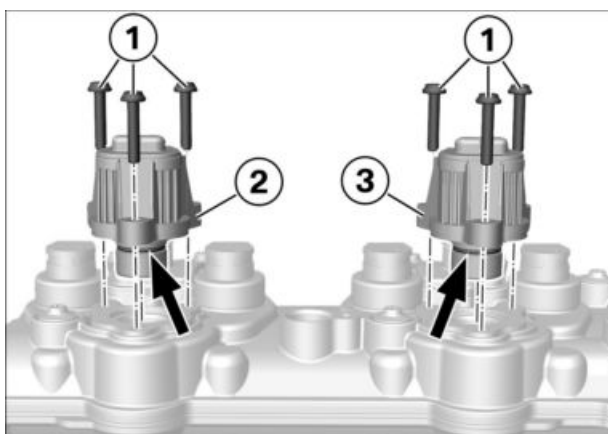

### ► Removing the left and right switching cam adjusters

- Remove screws **(1)**.
- Remove switching cam adjuster on left **(2)** and right **(3)** with O-rings **(arrows)**.

# 43

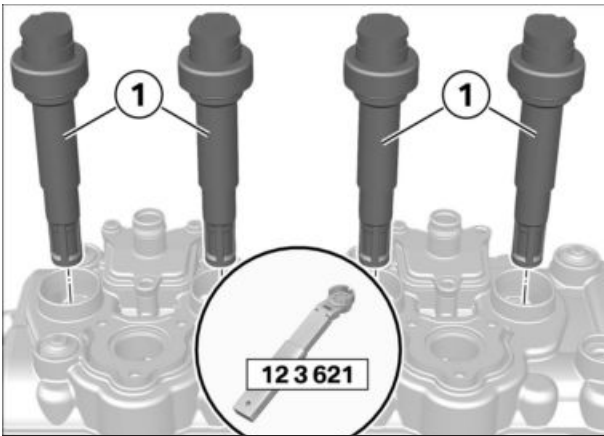

## ► Remove the direct ignition coils

- Clean the cylinder-head cover with compressed air.
- Remove direct ignition coils **(1)** using puller (12 3 621).



# 44

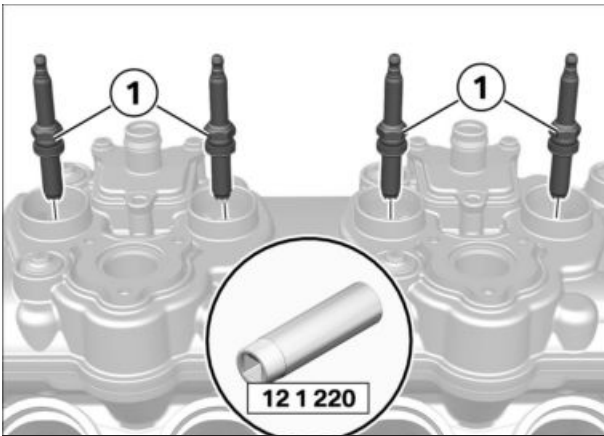

## ► Removing spark plugs

- Clean the spark plug shaft with compressed air.
- Remove spark plugs **(1)** with spark plug wrench (12 1 220).



# 45

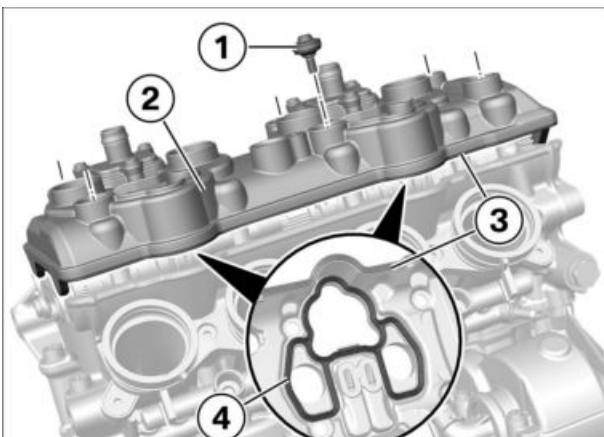

## ► Removing cylinder head cover

- Remove bolts **(1)** with seals .
- Remove cylinder head cover **(2)** with seals **(3)** and **(4)**.



# 46

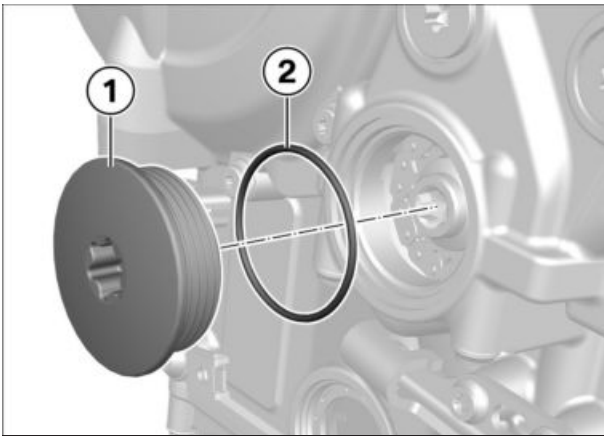

## ► Removing right crankshaft cover

- Remove crankshaft cover **(1)** with O-ring **(2)**.



# 47

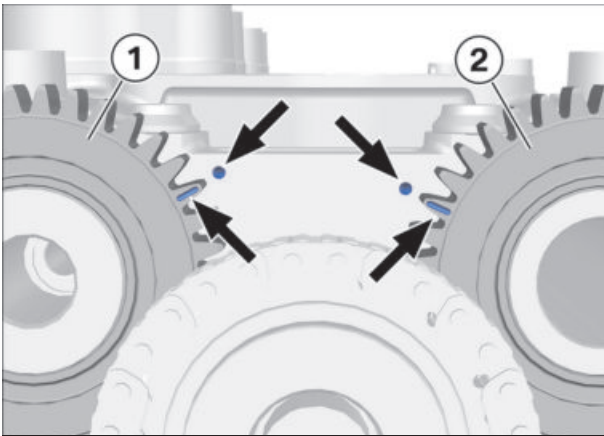

## ► Adjust engine to firing TDC

- Turn crankshaft on screw connection of the timing chain pinion in clockwise direction until marks on camshaft sprockets **(1)** and **(2)** are flush with marks on camshaft bearing bridge **(arrows)**.

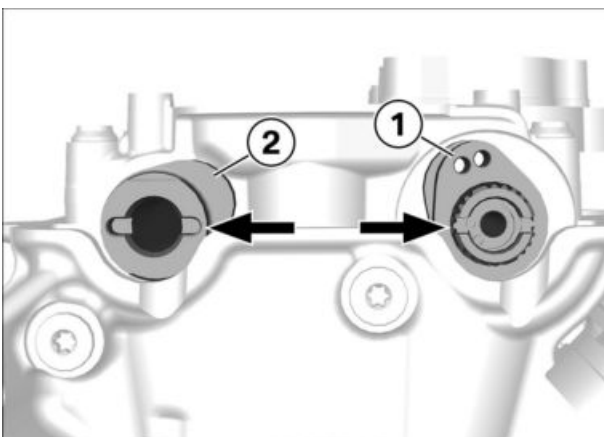

- Intake cam **(1)** and exhaust cam **(2)** for cylinder 1 are in position as shown and recesses **(arrows)** are flush with edge of housing.

» Firing TDC of cylinder 1 is set.



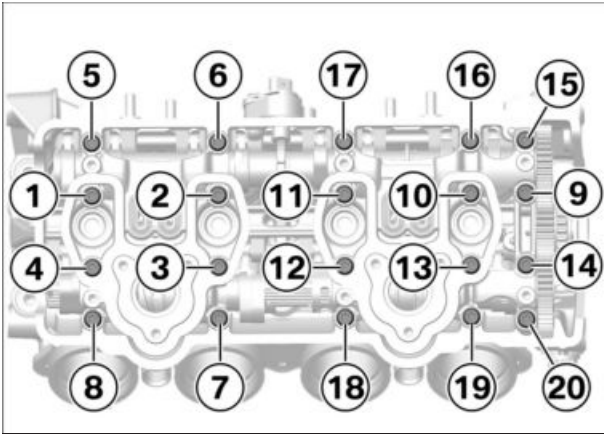

## ► Removing the camshaft bearing support

- Slacken the bolts evenly in sequence from **(20)** to **(1)**.

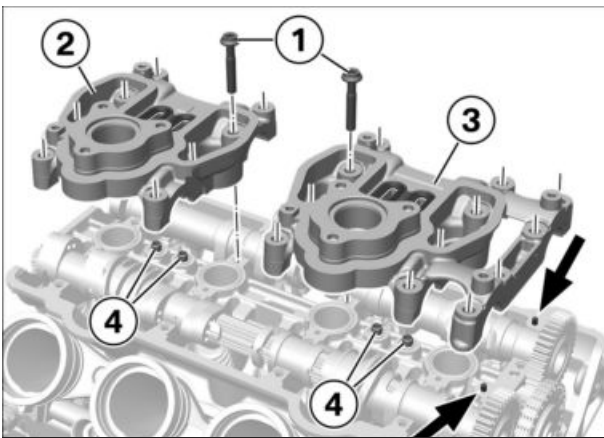

- Remove screws **(1)**.
- Remove camshaft bearing brackets **(2)** and **(3)**, thereby observing fitting sleeves **(4)** and dowel pins **(arrows)**.

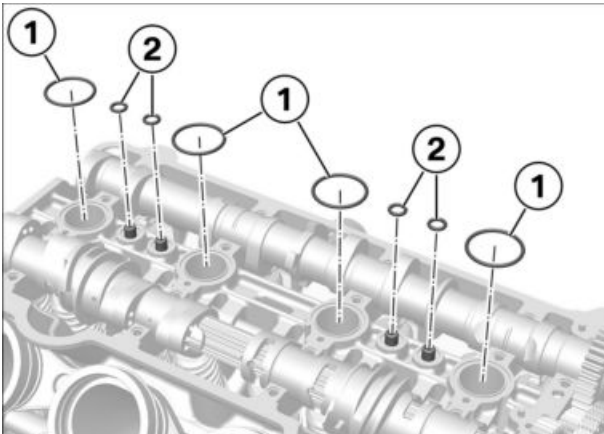

- Remove O-rings **(1)** and **(2)**.



## 49

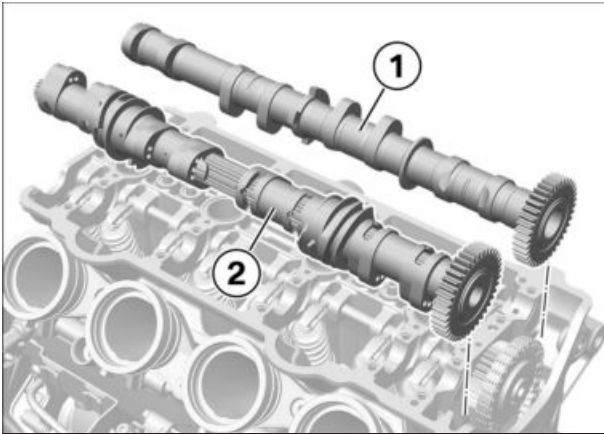

### ► Remove the camshafts

- Remove exhaust camshaft **(1)** and intake camshaft **(2)**.



## 50

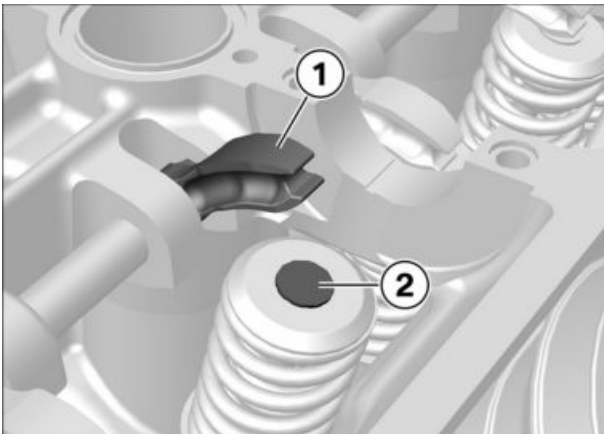

### ► Removing valve shims

- Swing rocker arm **(1)** up.
- Remove adjustment plate **(2)** from the valve and place it in the correct position in rack (11 1 844).



## 51

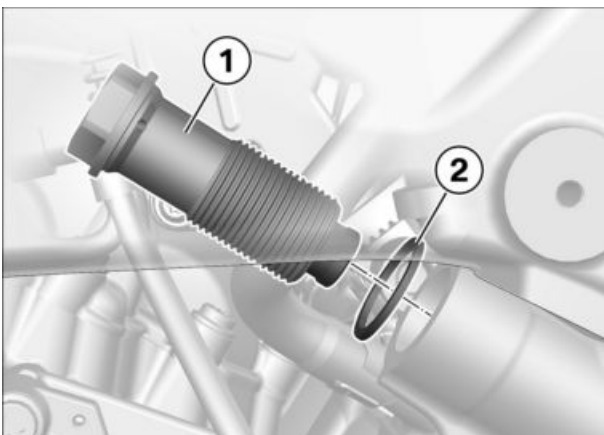

### ► Removing timing-chain tensioner

- Remove timing chain tensioner **(1)** with sealing ring **(2)**.



## 52

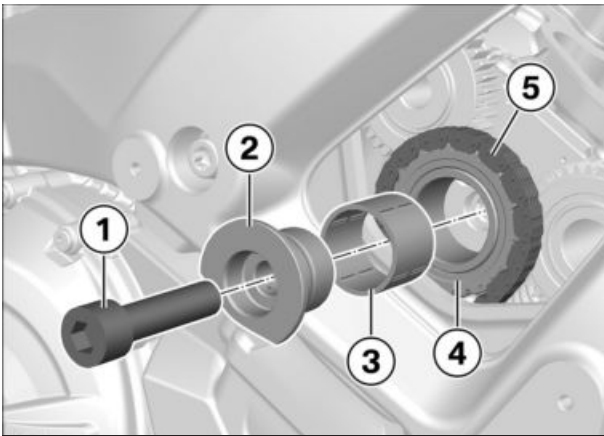

### ► Removing chain sprocket reduction gear for camshafts

- Remove bolt (1).
- Remove axle (2) with needle bearing (3).
- Feed out chain sprocket (4) from timing chain (5) and remove.



## 53

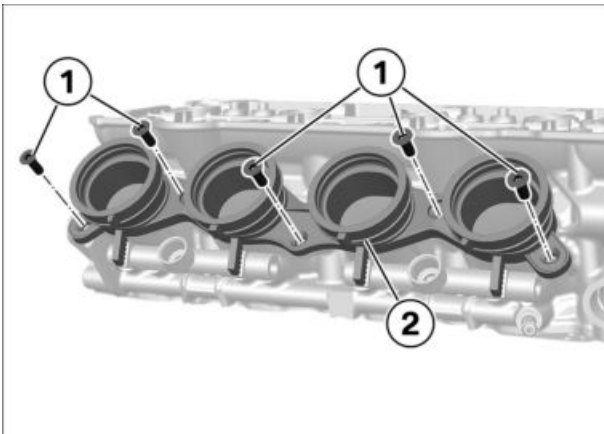

### ► Removing air intake stub

- Remove screws (1).
- Remove air intake stub (2).



## 54

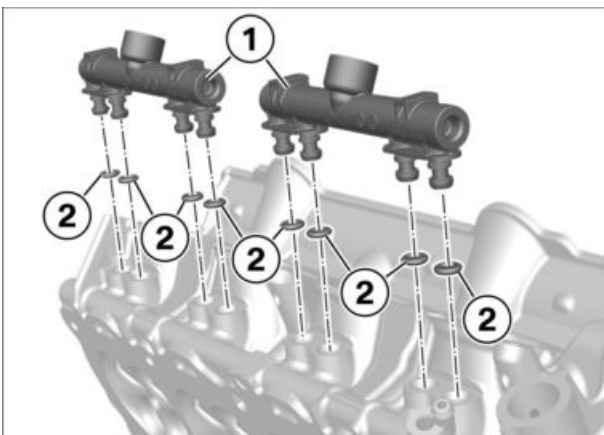

### ► Remove bypass distributor

- Remove bypass distributor (1) with O-rings (2).



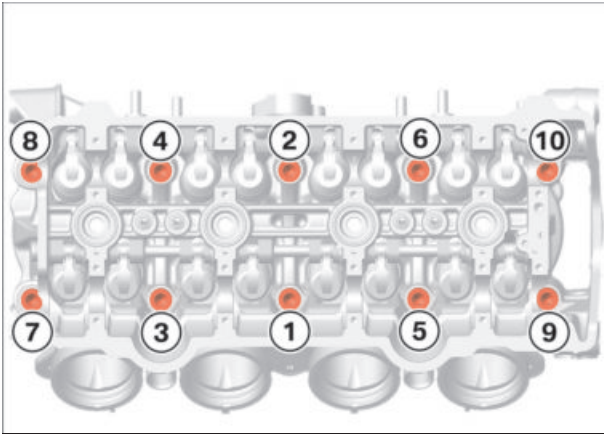

## ► Removing cylinder head

- Slacken the screws in reverse sequence from **(10)** to **(1)**.

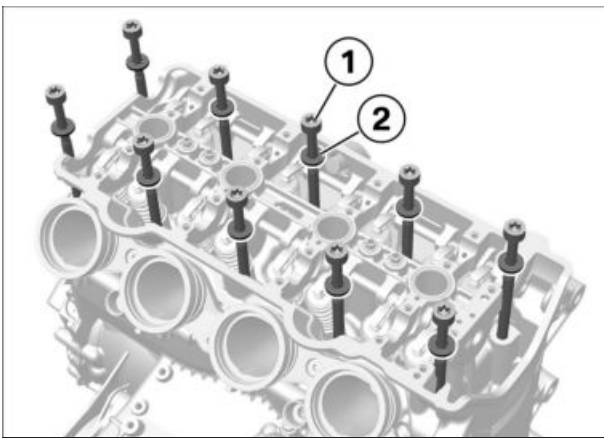

- Remove screws **(1)** with washers **(2)**.

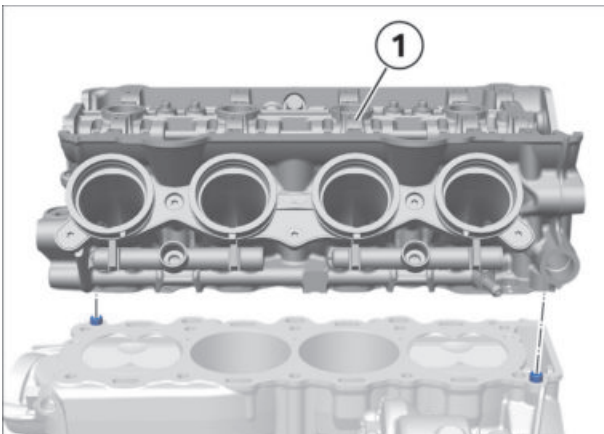

- Remove **(1)** cylinder head.

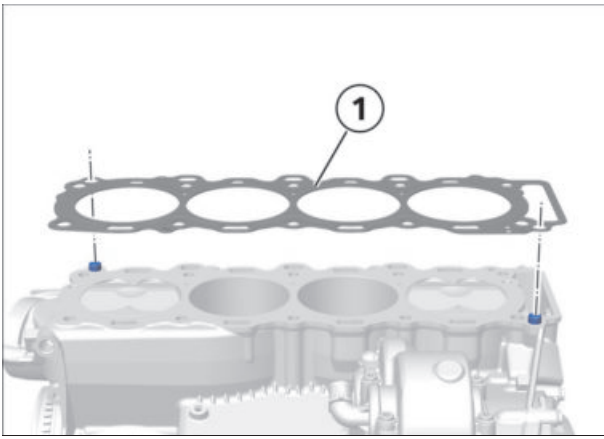

- Removing cylinder head gasket (1).

## 56

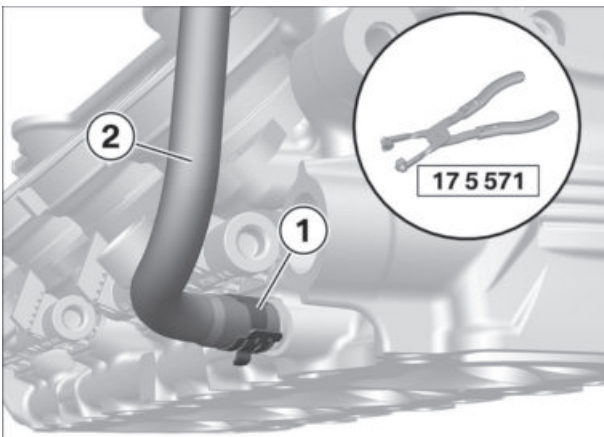

### ► Removing coolant venting hose

- Release clamp (1) with pliers (17 5 571).
- Pull off coolant venting hose (2).

## 57

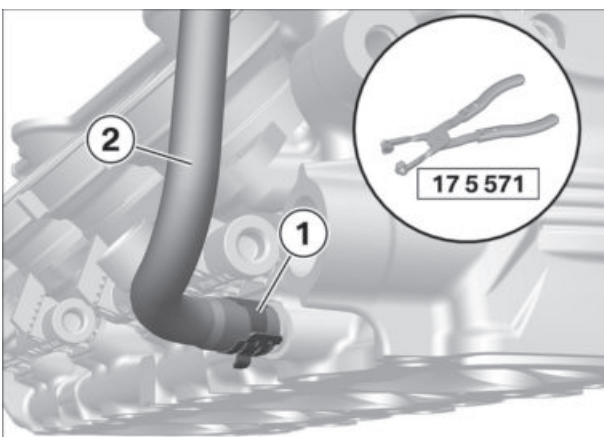

### ► Installing coolant vent hose on new cylinder head

- Slide on coolant venting hose (2).
- Secure clamp (1) with pliers (17 5 571) while aligning it with mark.

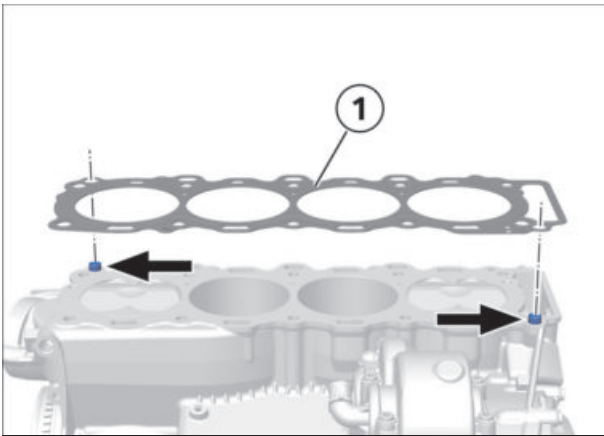

## ► Installing cylinder head

- Clean the sealing surfaces.
- Install cylinder head gasket **(1)** and align fitting sleeves **(arrows)**.

### NOTICE

If the power train, engine housing, piston, crankshaft or connecting rod will be replaced, measure the piston protrusion to determine the correct cylinder head gasket.

### NOTICE

The **new** cylinder-head gasket must be **the same thickness** as the cylinder-head gasket it replaces.

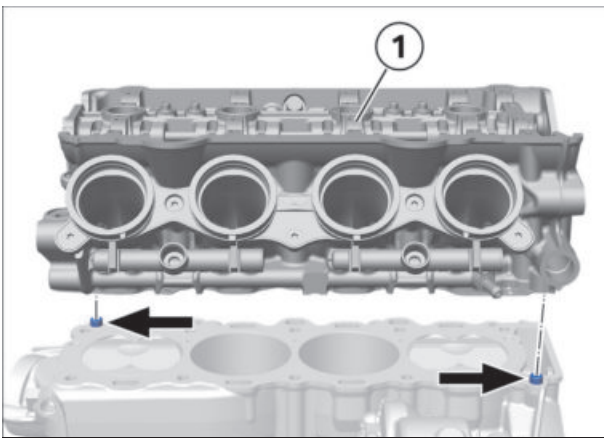

- Install cylinder head **(1)**, noting the passing sleeves **(arrows)**.

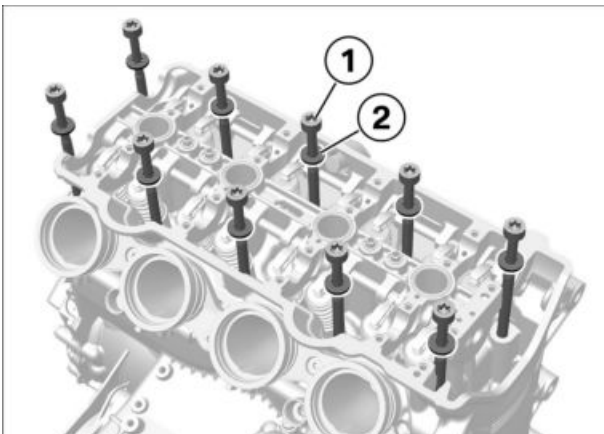

- Degrease bolts **(1)** with washers **(2)**.
- Insert screws **(1)** with washers **(2)**, but do not tighten them.

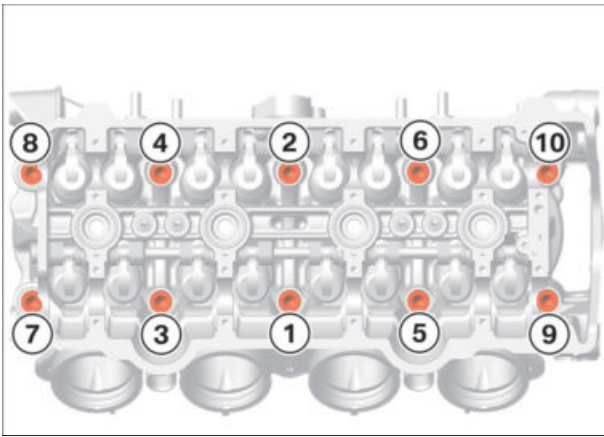

- Tighten bolts in specified sequence **(1)** to **(10)**.

 <b>Tightening torques</b>		
<b>Cylinder head to crankcase</b>		
M8	1st tightening torque, 20 Nm	
	1st additional angle of rotation, 90°	
	2nd additional angle of rotation, 90°	
	3. Additional angle of rotation, 45°	

## 59

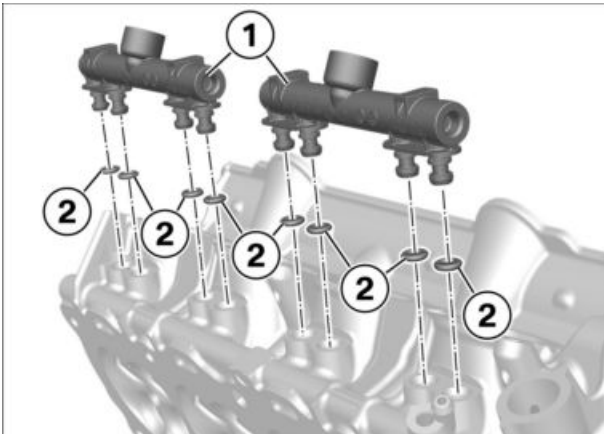

### ► Installing bypass distributor

- Check O-rings **(2)** and renew, if required.
- Lubricate O-rings **(2)**.

 <b>Installation tool</b>	
Silicone spray	83 19 2 208 609

- Install bypass distributor **(1)** with O-rings **(2)**.

## 60

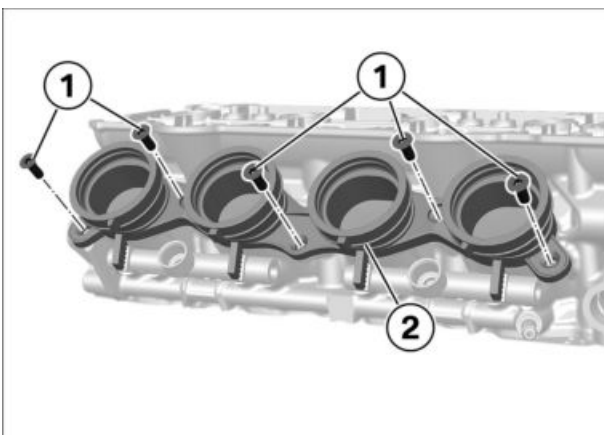

### ► Install intake manifold

- Clean the threads.
- Position intake manifold **(2)**.
- Install screws **(1)**.

 <b>Tightening torques</b>		
<b>Air intake to cylinder head</b>		
M6 x 16, Renew screw	8 Nm	
Thread-locking compound (micro-encapsulated)		

# 61

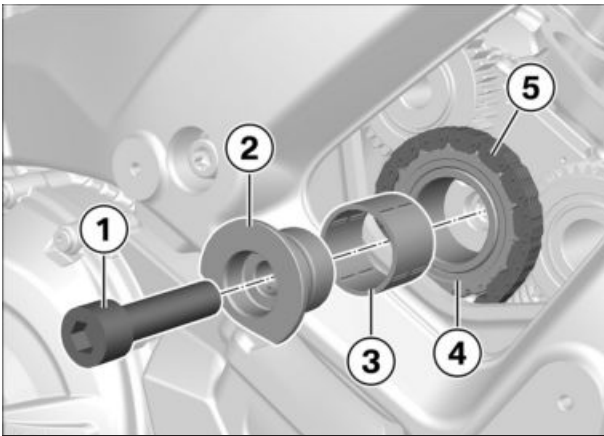

## ▶ Installing chain sprocket reduction gear for camshafts

- Insert chain sprocket (4) into timing chain (5).
- Insert needle bearing (3) in axle (2).
- Install bolt (1) and counter-hold axle (2) with suitable tool.

Tightening torques		
Axle for timing chain drive reduction gear to cylinder head		
M10 x 40	60 Nm	

# 62

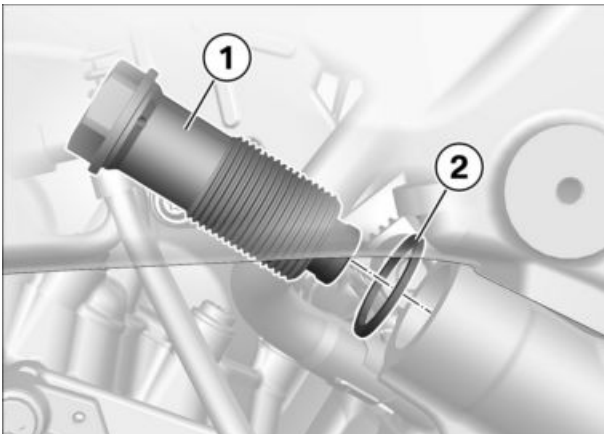

## ▶ Installing timing chain tensioner

- Renew sealing ring (2).
- Install timing chain tensioner (1) with sealing ring (2).

Tightening torques		
Timing-chain tensioner to cylinder head		
M20 x 1.5	42 Nm	

# 63

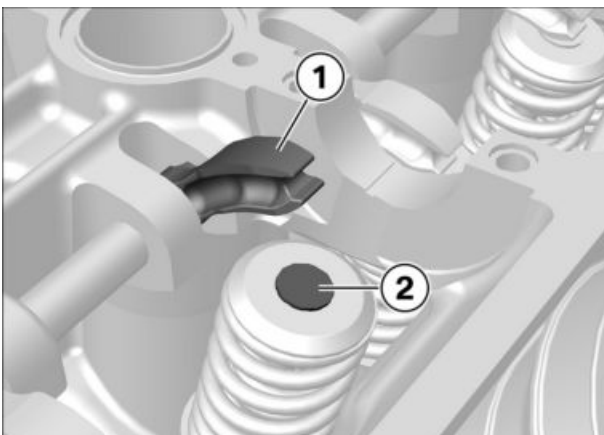

## ▶ Installing valve shim

- Place lightly oiled adjustment plate (2) on the valve.
- Swing rocker arm (1) down.

## ► Installing camshafts

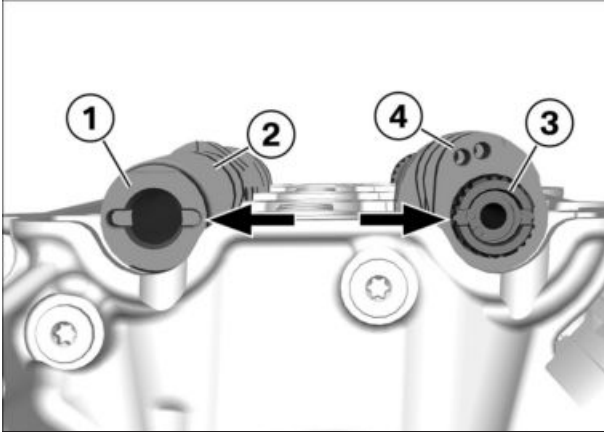

- Lubricate camshafts at bearing positions with engine oil.
- Install exhaust camshaft **(1)** and align to firing TDC of cylinder 1.
  - » Recess on camshaft **(arrows)** edge of housing of cylinder head flush, cams **(2)** point up.
- Install intake camshaft **(3)** and align to firing TDC of cylinder 1.
  - » Recess on camshaft **(arrows)** edge of housing of cylinder head flush, cams **(4)** point up.

## ► Installing camshaft bearing bridges

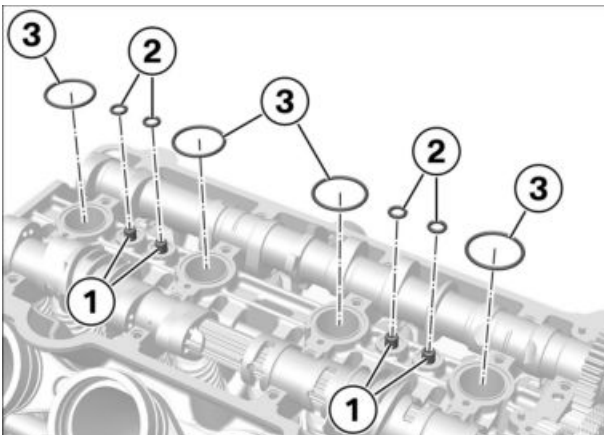

- Make sure that fitting sleeves **(1)** are installed in the cylinder head.
- Install **new** O-rings **(2)** and **(3)**.

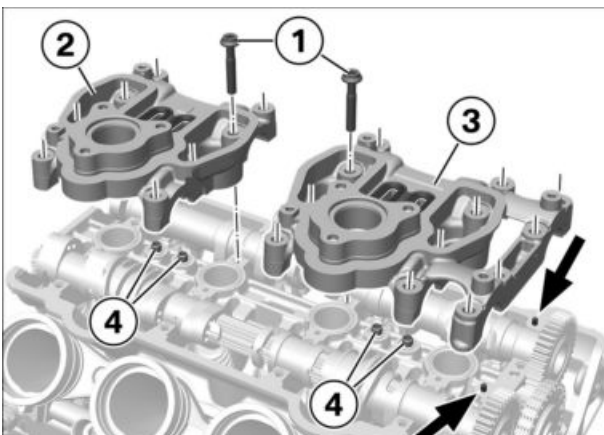

- Make sure that dowel pins **(arrows)** are installed in cylinder head.

### **ATTENTION**

#### **Incorrectly positioned camshaft axial guide**

Component damage

- Before tightening down the fasteners of the bearing cap, make sure that the camshaft axial guide is correctly positioned.

- Position and align camshaft bearing bridges **(3)** and **(2)**, while observing fitting sleeves **(4)** and dowel pins **(arrows)**.
- Fit bolts **(1)**, do not tighten.

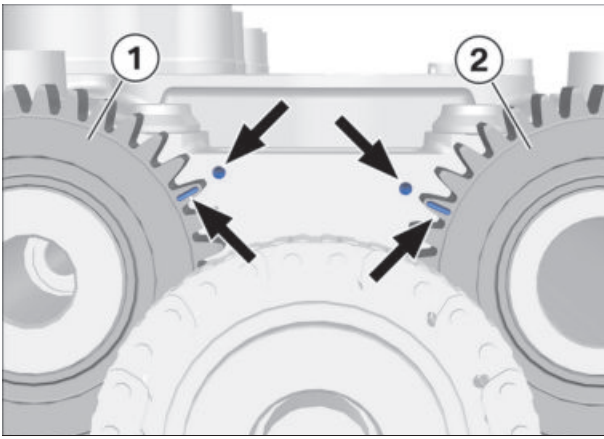

- Check if marks on camshaft sprockets and camshaft bearing bridge (**arrows**) are flush; remove camshaft bearing bridges and correct the position of the camshafts where required.

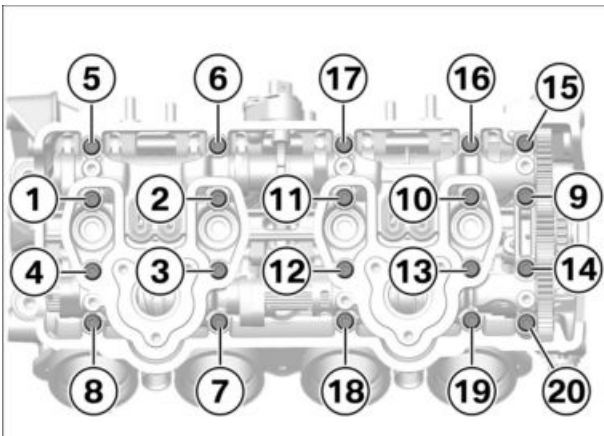

- Tighten bolts in sequence **(1) to (20)**.

 <b>Tightening torques</b>		
<b>Camshaft bearing cap to cylinder head</b>		
M6 x 35	<b>Tightening sequence: See repair manual</b>	
	1st tightening torque, 5 Nm	
	2nd tightening torque, 13 Nm	

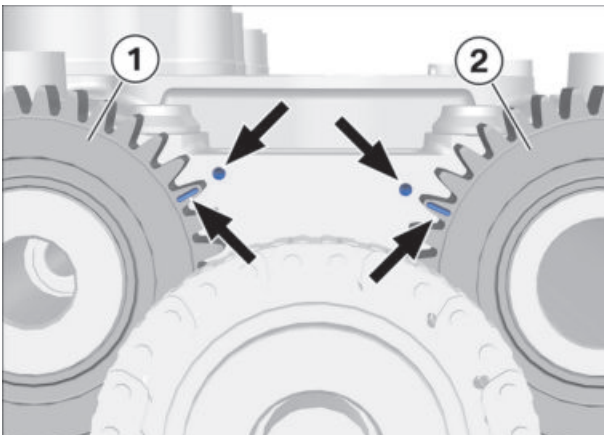

- Check if marks on camshaft sprockets and camshaft bearing bridge (**arrows**) are flush; remove camshaft bearing bridges and correct the position of the camshafts where required.



► **Adjusting valve clearance**

▷ **Removing the camshaft bearing support**

- Slacken the bolts evenly in sequence from **(20)** to **(1)**.

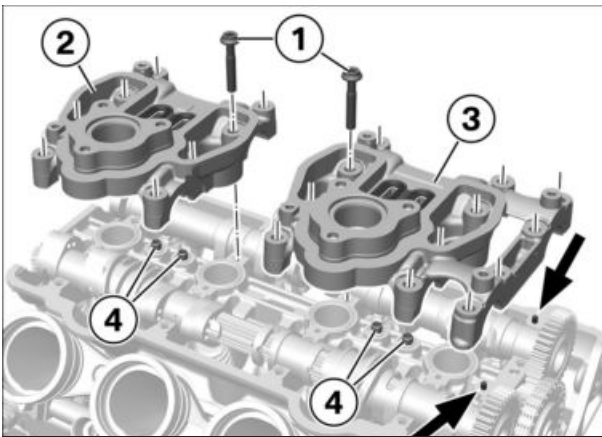
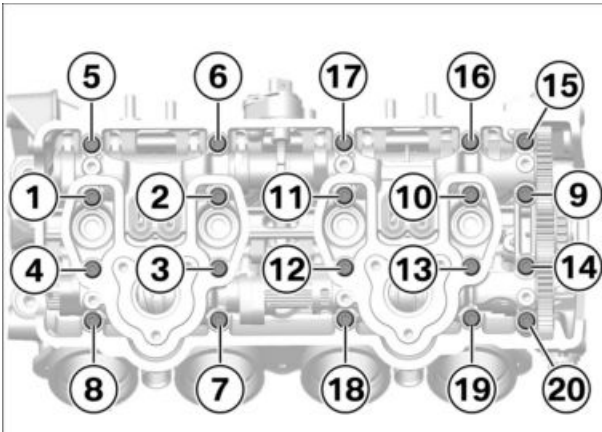

- Remove screws **(1)**.
- Remove camshaft bearing brackets **(2)** and **(3)**, thereby observing fitting sleeves **(4)** and dowel pins **(arrows)**.

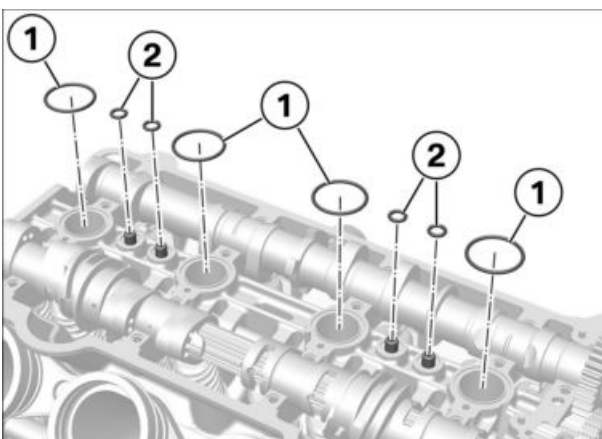

- Remove O-rings **(1)** and **(2)**.

◁

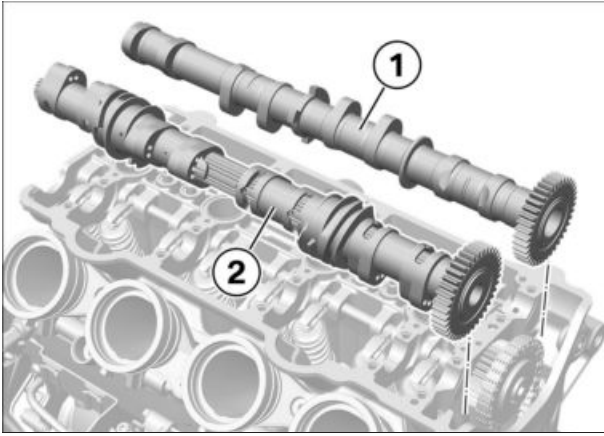

### ▷ Remove the camshafts

- Remove exhaust camshaft **(1)** and intake camshaft **(2)**.

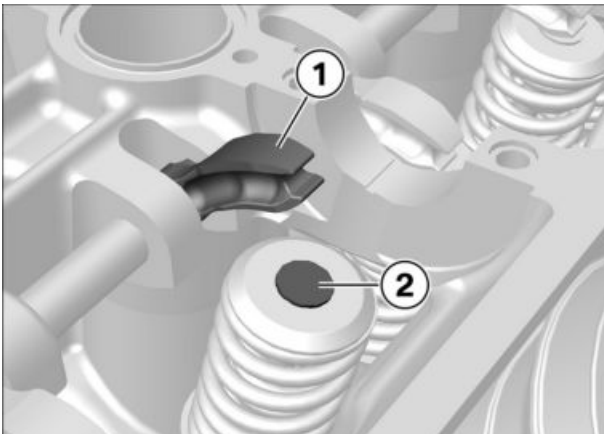

### ▷ Removing valve shims

- Swing rocker arm **(1)** up.
- Remove adjustment plate **(2)** from the valve and place it in the correct position in rack (11 1 844).



- Check the thickness of the adjustment plates with a caliper gauge.
- Determine the thickness of the new adjustment plate in accordance with the valve clearance measurement.

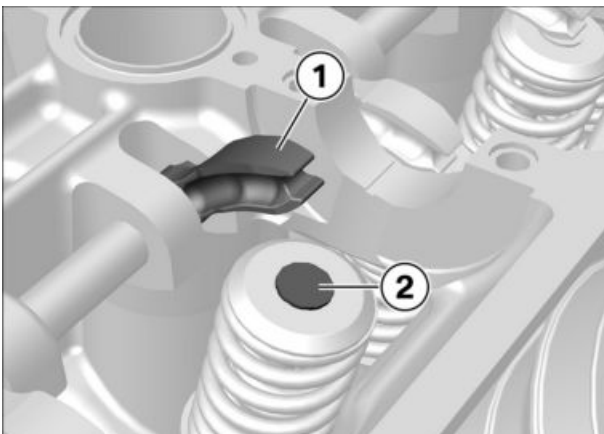

### ▷ Installing valve shim

- Place lightly oiled adjustment plate **(2)** on the valve.
- Swing rocker arm **(1)** down.



### ▷ Installing camshafts

- Lubricate camshafts at bearing positions with engine oil.

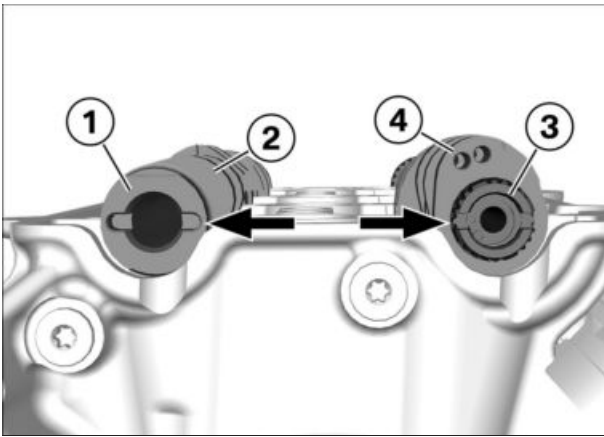

- Install exhaust camshaft **(1)** and align to firing TDC of cylinder 1.
- » Recess on camshaft **(arrows)** edge of housing of cylinder head flush, cams **(2)** point up.
- Install intake camshaft **(3)** and align to firing TDC of cylinder 1.
- » Recess on camshaft **(arrows)** edge of housing of cylinder head flush, cams **(4)** point up.

△

### ▽ Installing camshaft bearing bridges

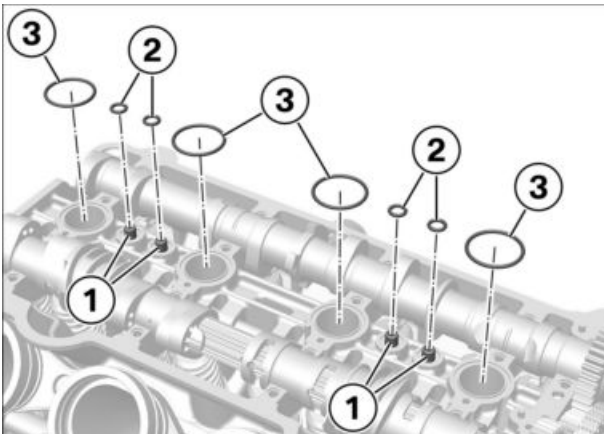

- Make sure that fitting sleeves **(1)** are installed in the cylinder head.
- Install **new** O-rings **(2)** and **(3)**.

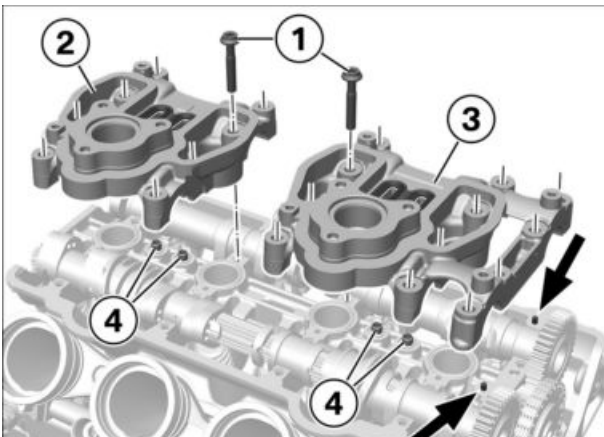

- Make sure that dowel pins **(arrows)** are installed in cylinder head.

### **ATTENTION**

#### **Incorrectly positioned camshaft axial guide**

Component damage

- Before tightening down the fasteners of the bearing cap, make sure that the camshaft axial guide is correctly positioned.

- Position and align camshaft bearing bridges **(3)** and **(2)**, while observing fitting sleeves **(4)** and dowel pins **(arrows)**.

- Fit bolts **(1)**, do not tighten.

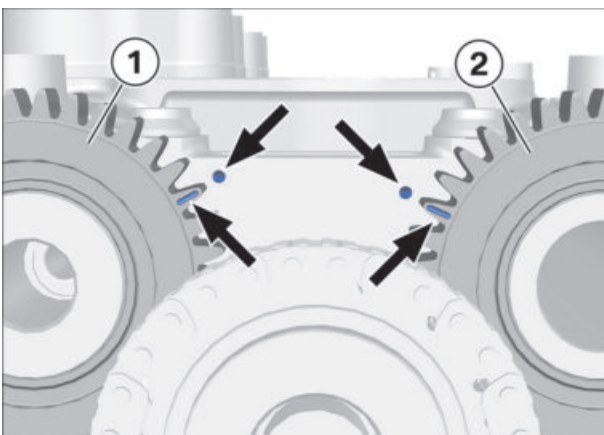

- Check if marks on camshaft sprockets and camshaft bearing bridge **(arrows)** are flush; remove camshaft bearing bridges and correct the position of the camshafts where required.

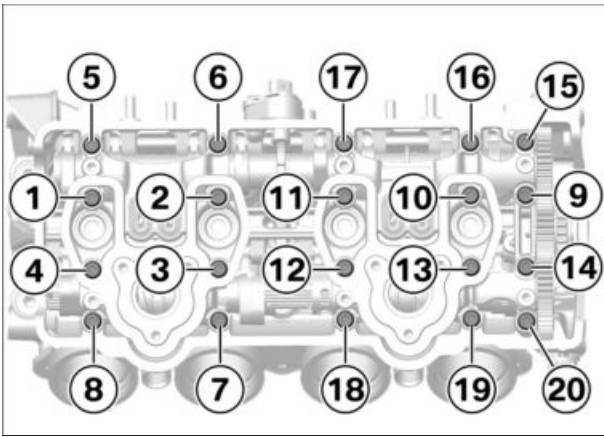

- Tighten bolts in sequence **(1) to (20)**.

 <b>Tightening torques</b>		
<b>Camshaft bearing cap to cylinder head</b>		
M6 x 35	<b>Tightening sequence:</b> <b>See repair manual</b>	
	1st tightening torque, 5 Nm	
	2nd tightening torque, 13 Nm	

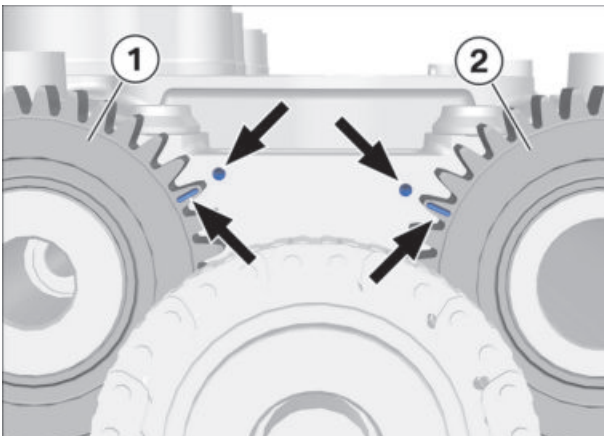

- Check if marks on camshaft sprockets and camshaft bearing bridge (**arrows**) are flush; remove camshaft bearing bridges and correct the position of the camshafts where required.



# 68

## ► Recheck the valve clearance

- After assembly, recheck valve clearances for all cylinders.

 <b>Technical data</b>			
Inlet valve clearance	Engine cold	0.14...0.2 mm	
Exhaust valve clearance	Engine cold	0.2...0.26 mm	



► **Checking timing**

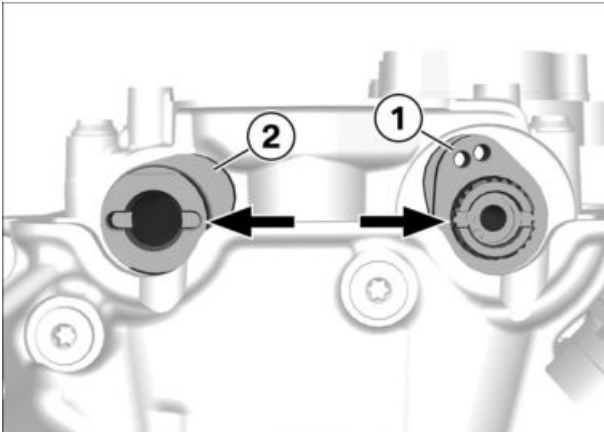

▷ **Adjust engine to firing TDC**

- Turn crankshaft on screw connection of alternator in counter-clockwise direction until intake cam **(1)** and exhaust cam **(2)** for cylinder 1 are in the position shown and recesses **(arrows)** are flush with edges of housing.

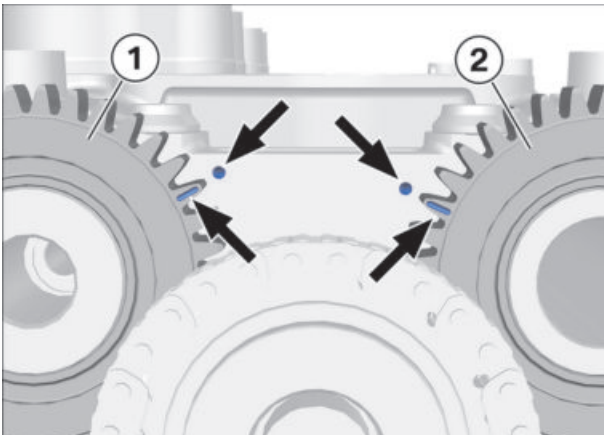

- Check if marks on camshaft sprockets **(1)** and **(2)** are flush with marks on camshaft bearing bridge **(arrows)**.
- » Firing TDC of cylinder 1 is set.

△

▷ **Lock the crankshaft in TDC position**

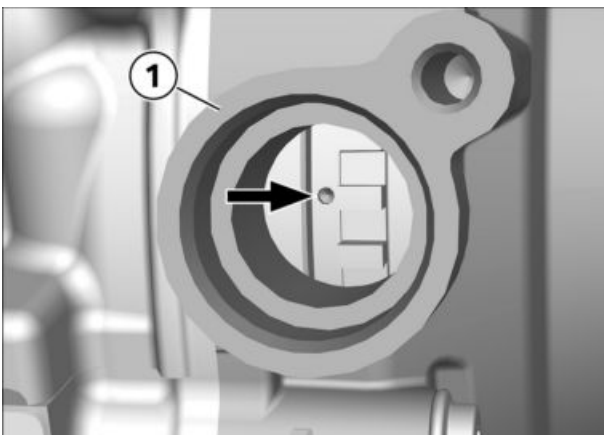

- Check if TDC mark **(arrow)** is visible through opening in left engine cover **(1)**.

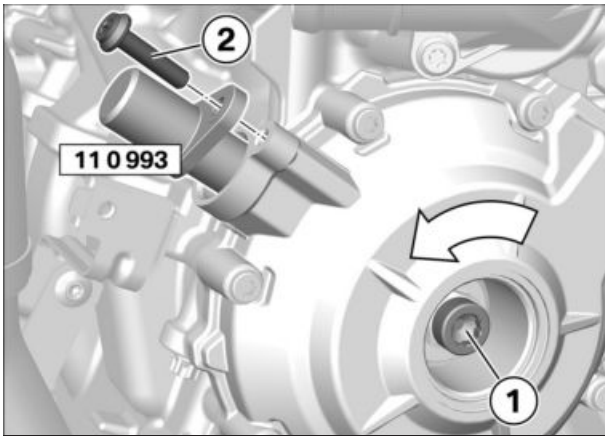

- Insert alignment pin (11 0 993) until it noticeably engages to limit position and, if necessary, turn crankshaft on bolt (1) in **counter-clockwise direction**.

#### NOTICE

Crankshaft must always be turned in direction of rotation. If the alignment pin does not engage, turn crankshaft two rotations in counterclockwise direction until the firing TDC for Cylinder 1 is reached.

- Install bolt (2).

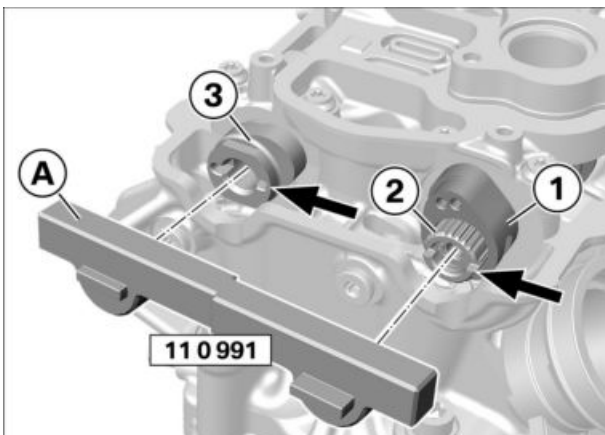

- Slide sliding piece (1) to the inside.

#### Check

- Attach holding fixture (11 0 991) with side A CHECK on camshafts (2) and (3).
- » Chain guard (11 0 991) must rest flat on edge of housing and test springs must slide to limit position in grooves (**arrows**) without great force.

#### Result

Chain guard cannot be pushed on.

#### Measure

- Adjust timing (cylinder head cover removed) (description in labour operation: 11 30 501, to be billed as a separate line item)

#### Result

Chain guard can be pushed on.

#### Measure

- Remove holding fixture (11 0 991) from camshafts (2) and (3).
- Slide sliding piece (1) to the outside.



#### Removing locating pin

- Remove bolt (1).
- Remove locating pin (11 0 993).

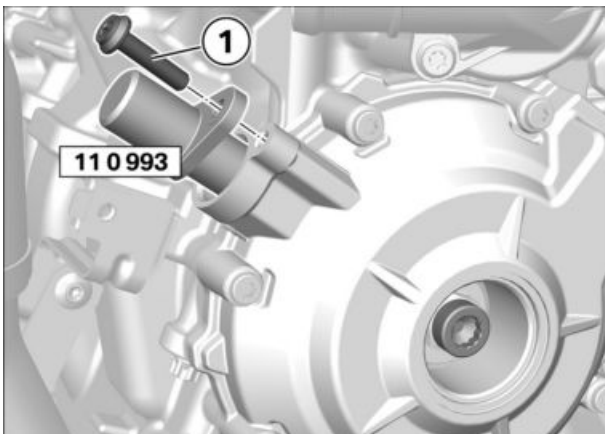

# 70

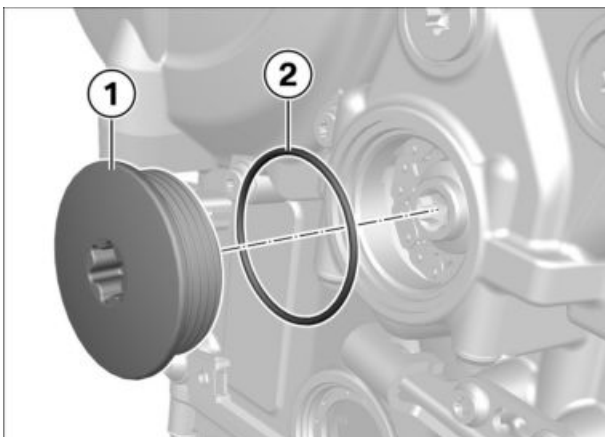

## ► Installing right crankshaft cover

- Check O-ring **(2)** and replace if required.
- Install crankshaft cover **(1)** with O-ring **(2)**.

 <b>Tightening torques</b>		
<b>Screw plug for crankshaft</b>		
M40	12 Nm	

# 71

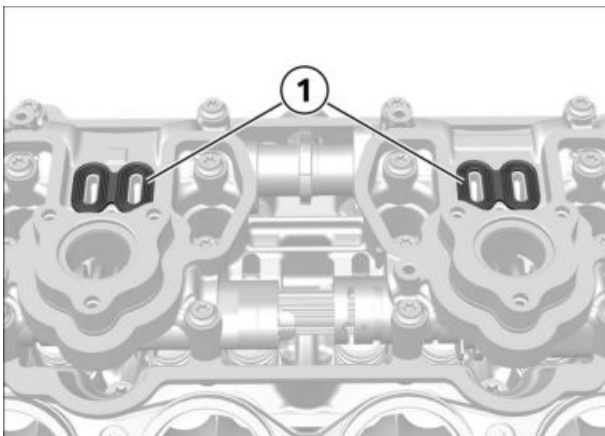

## ► Installing cylinder head cover

- Check seals **(1)** for SLS system and replace as needed.
- Make sure that seals **(1)** are installed.

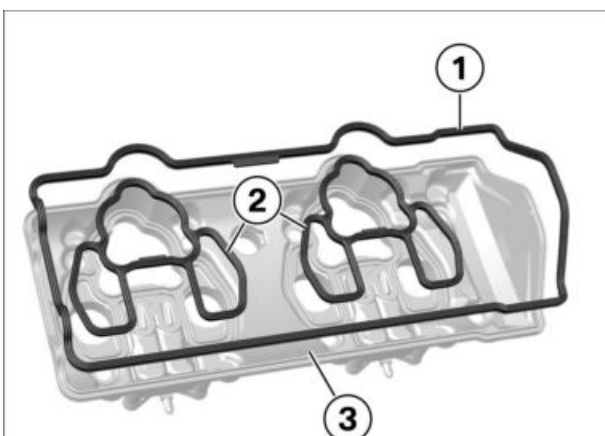

- Make sure that seals **(1)** and **(2)** are installed in cylinder head cover **(3)**.

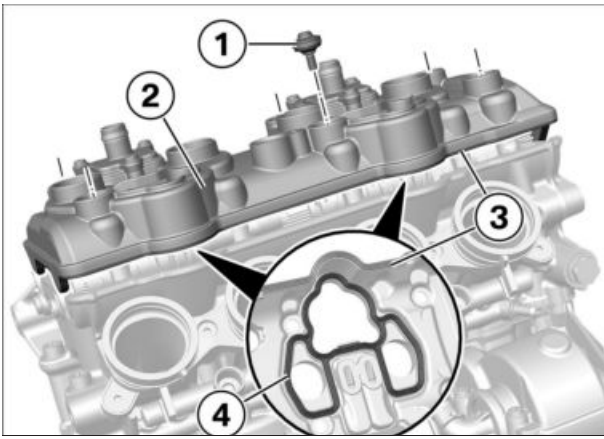

- Install cylinder head cover **(2)** with seals **(3)** and **(4)**.
- Before installing the bolts **(1)**, check if seals **(3)** and **(4)** are resting correctly on the sealing surfaces.
- Install screws **(1)** with seals.

 <b>Tightening torques</b>		
<b>Cylinder head cover to cylinder head</b>		
M6 x 20	10 Nm	

## 72

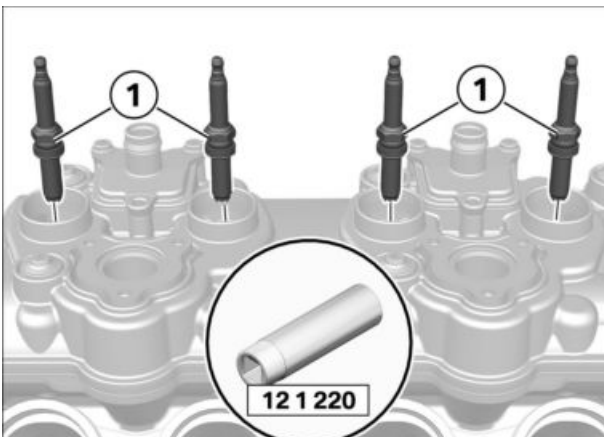

### ► Installing spark plugs

- Install spark plugs **(1)** with spark-plug wrench (12 1 220).

 <b>Tightening torques</b>		
<b>Spark plug in cylinder head</b>		
M10 x 1	12 Nm	

## 73

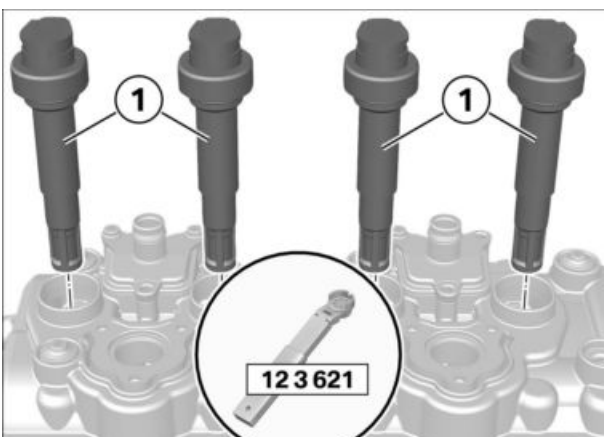

### ► Installing direct ignition coils

- Install direct ignition coils **(1)**.
  - » Direct ignition coils must **engage**.
  - » All connectors point **exactly** in direction of travel.

# 74

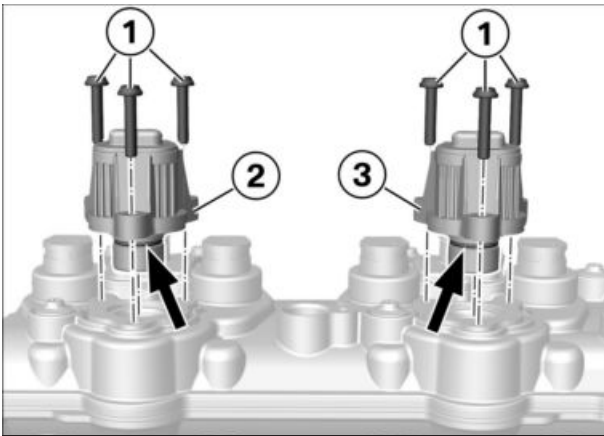

## ► Installing left and right switching cam adjuster

- Check O-rings (**arrows**) and replace, if required.
- Lubricate the O-rings (**arrows**) with engine oil.
- Install switching cam adjusters left (**2**) and right (**3**).
- Install screws (**1**).

Tightening torques		
Switching cam adjuster to camshaft bearing cap		
M6 x 30 - 10.9	13 Nm	

# 75

## ► Securing exhaust header

### NOTICE

Support the exhaust system to make it easier to remove and install the assembly.

- Insert exhaust manifold seals (**1**).

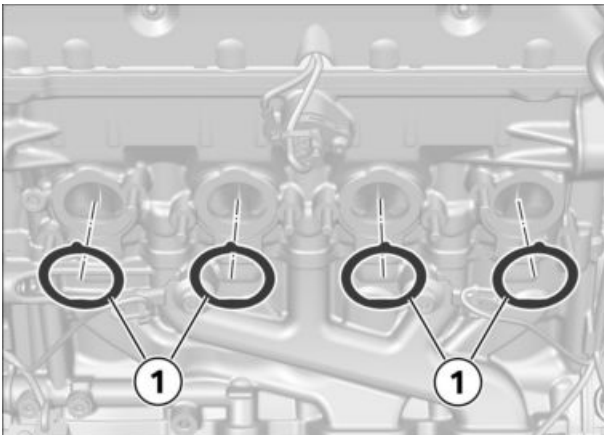

- Position exhaust manifold (**2**).
- Install nuts (**1**).

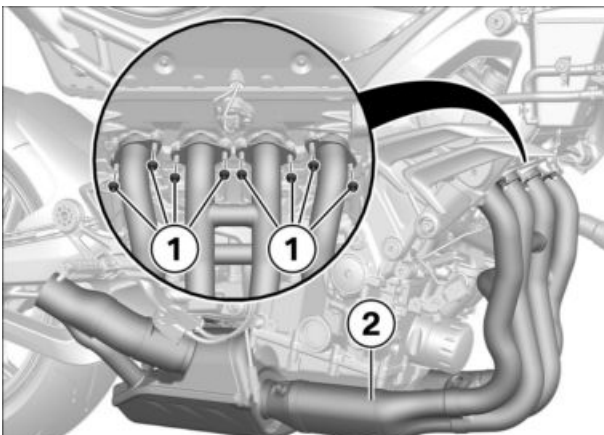

Tightening torques		
Exhaust manifold to cylinder head		
M7	14 Nm	

## ► Installing engine

### ATTENTION

#### Use of hard or sharp-edged objects in proximity to component

Component damage

- Take care not to scratch components; cover or mask as necessary.

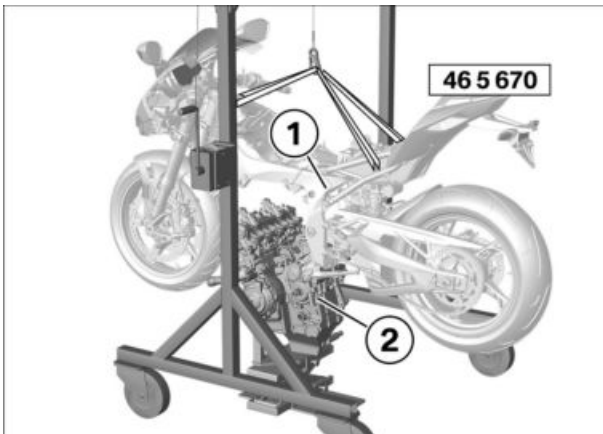

- Place motorcycle **(1)** on the frame with the assembly crane (46 5 670) over the engine and lower.
- Guide engine **(2)** into motorcycle **(1)** and position.

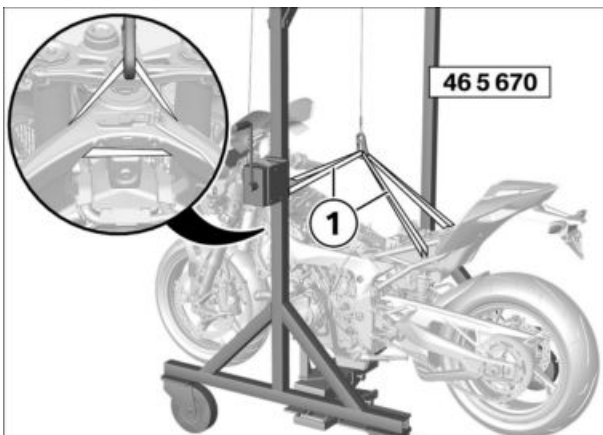

- Remove belts **(1)**.
- Remove assembly crane (46 5 670).

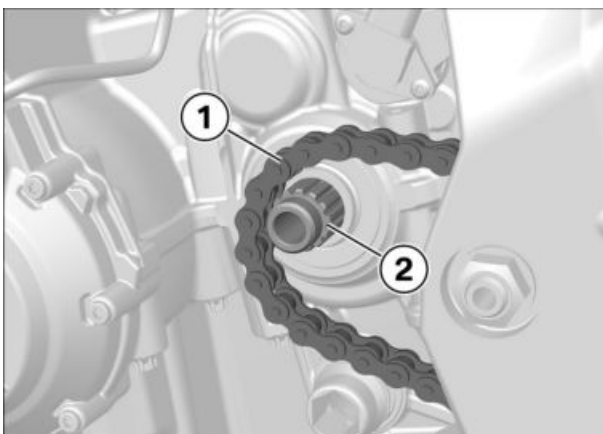

- Position engine with engine lifter so that the drive chain **(1)** can be guided onto the transmission output shaft.
- Guide drive chain **(1)** onto transmission output shaft **(2)**.

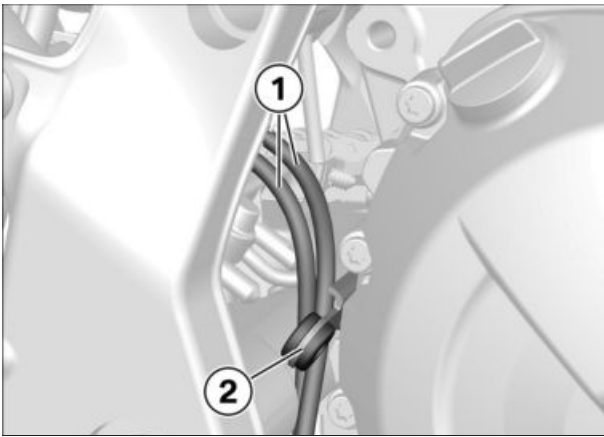

- Thread in Bowden cables **(1)** for exhaust flap on holder **(2)**.
- Lift engine with engine lifter and slide it to the rear.

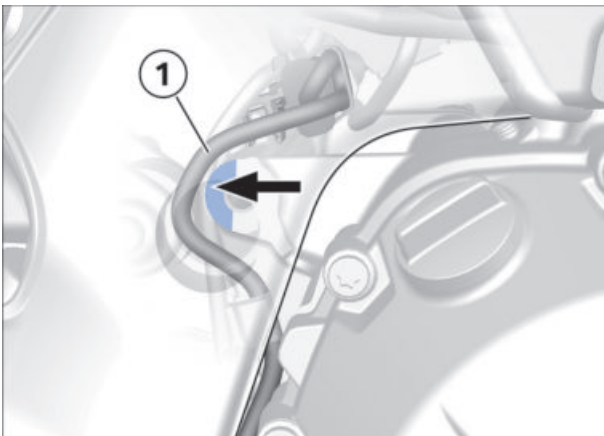

- Cable **(1)** for right monitoring oxygen sensor must be routed behind engine screw connection **(arrow)**.

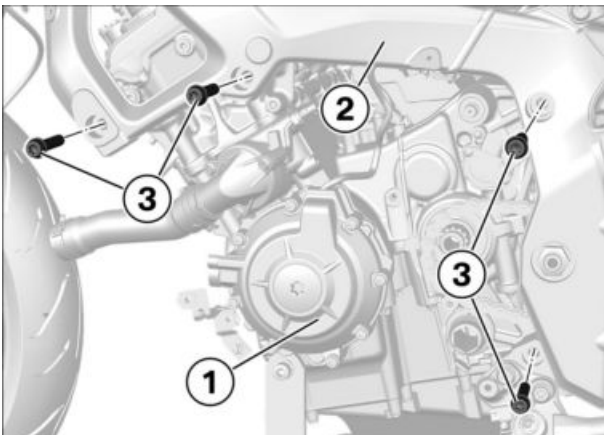

- Pull engine **(1)** to the left in frame **(2)** and position.
- Install screws **(3)** and tighten until hand-tight.

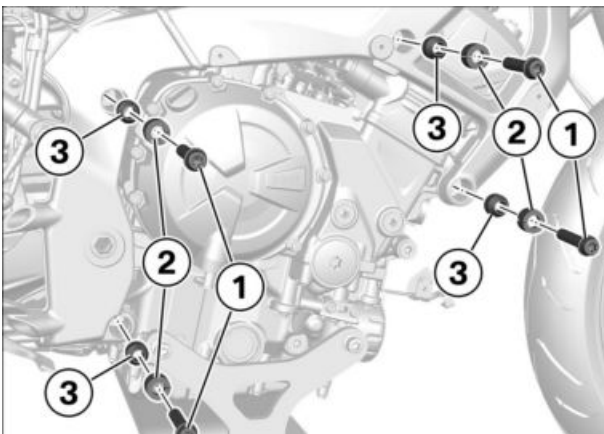

- Insert taper elements **(3)** with the **taper to the outside**.
- Insert expander elements **(2)** with **tapered side** facing taper element **(3)**.
- Install screws **(1)** and tighten until hand-tight.

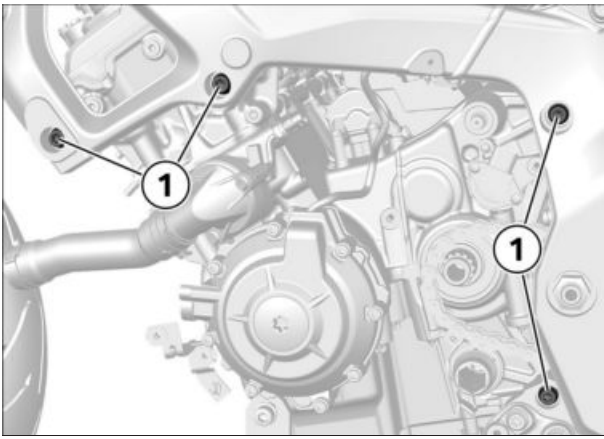

- Tighten screws **(1)**.

 <b>Tightening torques</b>		
<b>Engine to frame</b>		
Engine, left, to frame, M10 x 50	60 Nm	

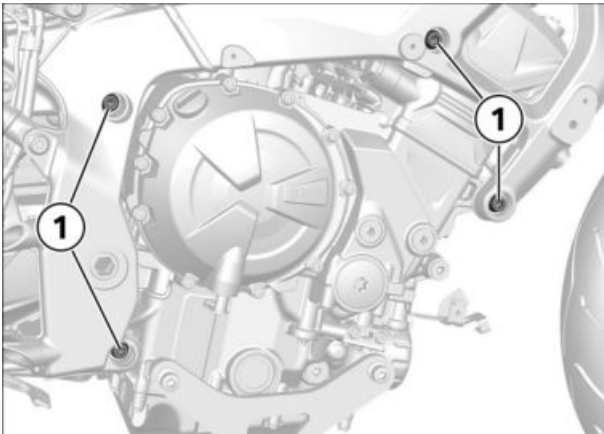

- Tighten screws **(1)**.

 <b>Tightening torques</b>		
<b>Engine to frame</b>		
Engine, right, to frame, M10 x 50, with taper elements (expander element outside)	90 Nm	
Renew screw		

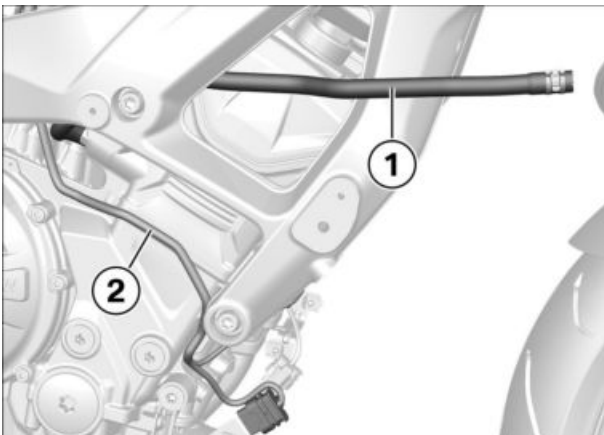

- Work out coolant venting hose **(1)** through the frame.
- Lay wiring harness **(2)** for front oxygen sensor and knock sensor to the front right.

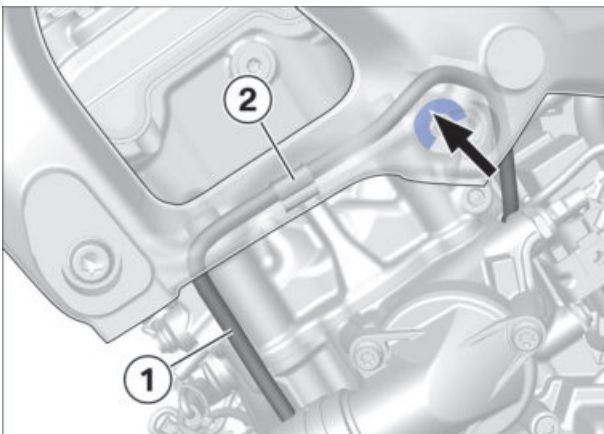

- Wiring harness **(1)** for front oxygen sensor and left knock sensor must be routed over the engine screw connection **(arrow)**.
- If necessary, secure wiring harness **(1)** in holder **(2)**.

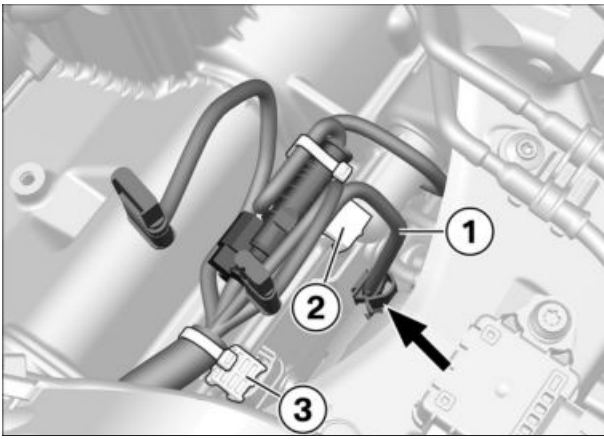

- Secure cable clip **(2)** and **(3)** with wiring harness on bridge of crankcase.
- Secure cable **(1)** for servomotor for exhaust flap in holder **(arrow)**.

## 77

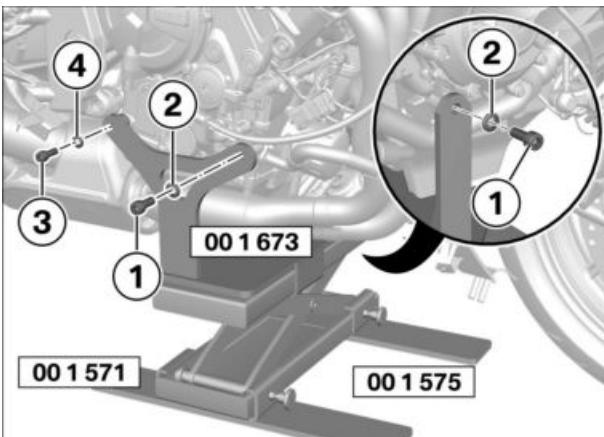

### ► Removing engine lifter

- Lower engine lifter until it is free of load. Make sure that the vehicle is standing securely on the rear-wheel stand and cannot topple.
- Remove scissor-type lifter (00 1 571) from engine adapter (00 1 673).
- Remove bolts **(1)** with washers **(2)** and bolt **(3)** with washer **(4)** and loosen engine fixture (00 1 673) from engine.
- Lower scissor-type lifter (00 1 571).
- Disengage extensions (00 1 575) from scissor-type lifter (00 1 571) and remove.

## 78

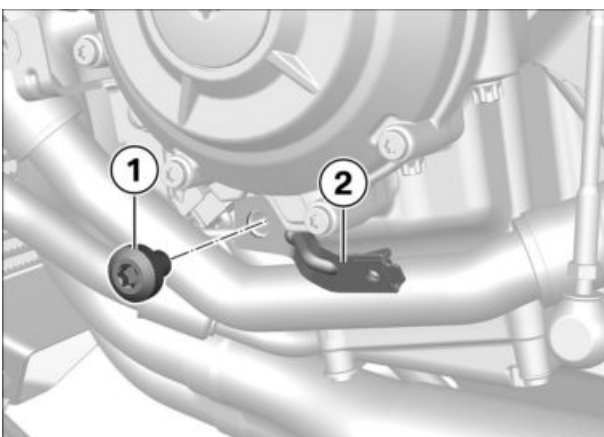

### ► Installing the holder for the left and right engine spoiler

- Position holder **(2)** and install bolt **(1)**.

Tightening torques		
<b>Bracket for rear left engine spoiler to engine</b>		
M10 x 12 - 10.9	19 Nm	

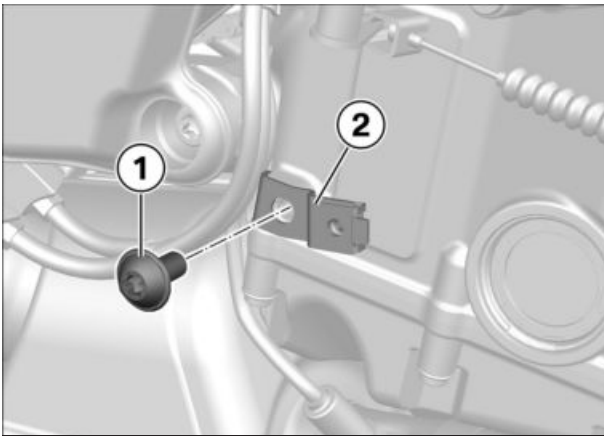

- Position holder **(2)** and install bolt **(1)**.

 <b>Tightening torques</b>		
<b>Bracket for engine spoiler right rear to engine</b>		
M8 x 16	19 Nm	

## 79

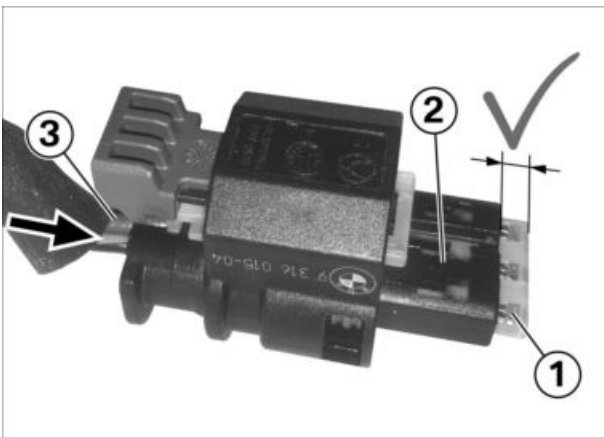

### ▶ Connecting oxygen sensors

#### ▷ Information for connecting vibration-resistant connectors

- Check if the contact carrier **(1)** protrudes significantly from the connector housing **(2)**.
- If necessary, hold down the connector housing **(2)** and slide contact carrier from the rear at the cable inlet **(3)** toward the front until the contact carrier **(1)** is visible

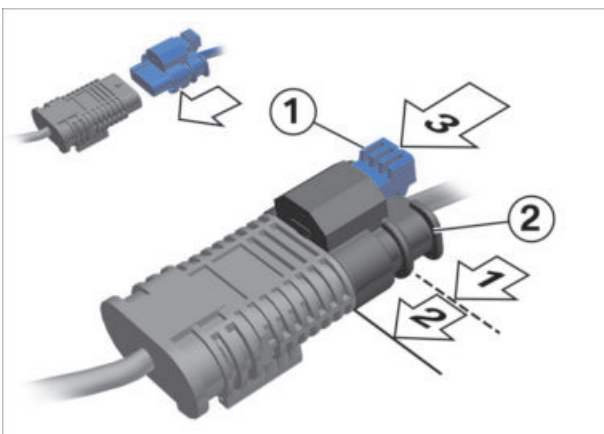

- Ensure that the release tab **(1)** is unlocked.
- Slide connector **(2)** in direction of arrow **(arrow 1)**.
  - » The connector **(2)** engages audibly.
- Slide connector **(2)** in direction of arrow **(arrow 2)** further.
  - » The connector **(2)** engages audibly.
- Slide locking tab **(1)** in direction of arrow **(arrow 3)**.
  - » The locking tab **(1)** engages audibly.

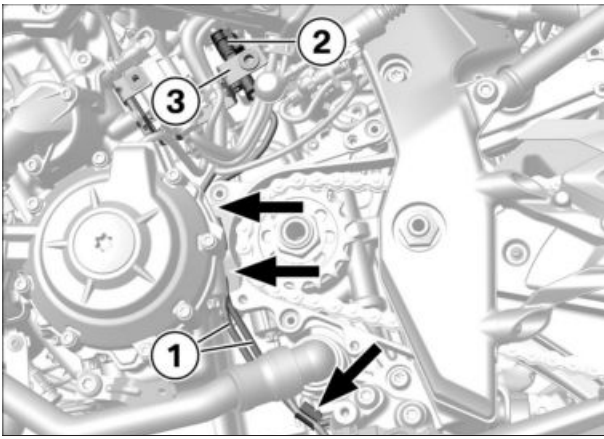

- Connect plug connection **(2)** for left monitoring oxygen sensor.
- Insert plug connection **(2)** behind relay holder **(3)** and secure.
- Secure cable **(1)** for monitoring oxygen sensor and side-stand switch in holder **(arrows)**.

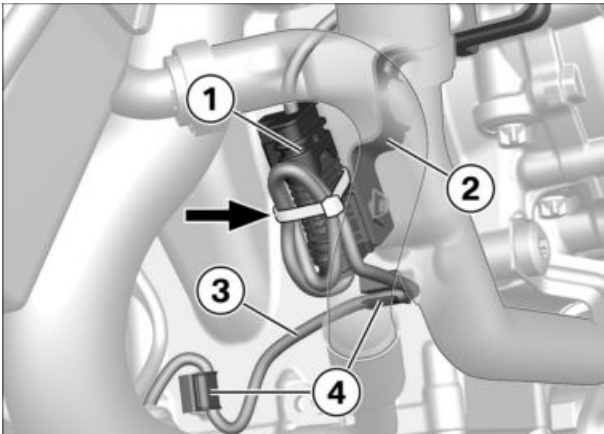

- Route cable **(3)** and secure in holder **(4)**.
- Connect plug connection **(1)** for left front oxygen sensor.
- Route excess cable lengths **(3)** in loops and secure with cable strap **(arrow)**.
- Secure plug connection **(1)** for left front oxygen sensor in holder **(2)**.

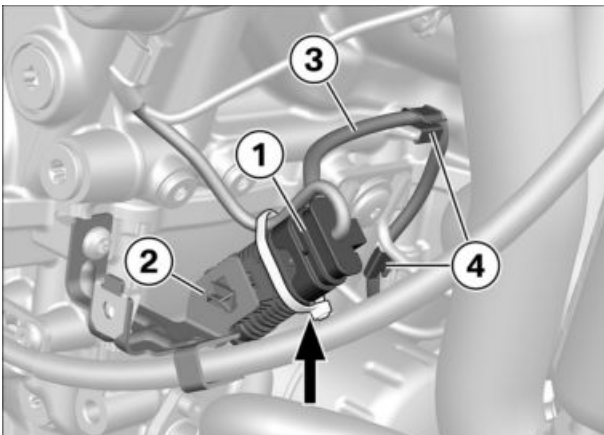

- Lay cable **(3)** and secure in holders **(4)**.
- Connect plug connection **(1)** for right front oxygen sensor.
- Secure plug connection **(1)** for right front oxygen sensor in holder **(2)**.
- Form excess cable lengths **(3)** into loops and secure cable strap **(arrow)**.

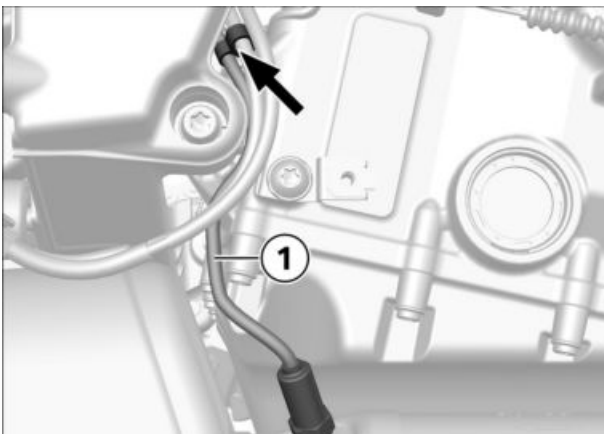

- Secure the cable **(1)** in the holder **(arrow)**.

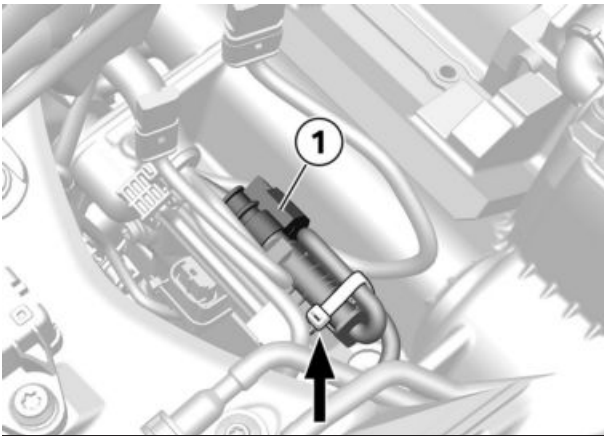

- Connect plug connection **(1)**.
- Secure the cable strap **(arrow)**.

80

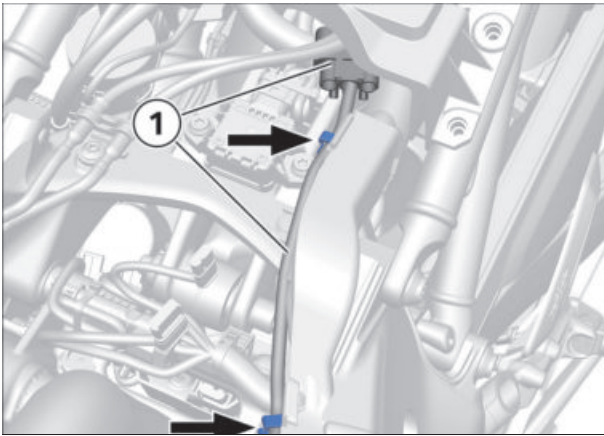

► **Securing cable for voltage regulator**

- Work cable **(1)** for alternator in through frame, route to the rear and secure in holders **(arrows)**.

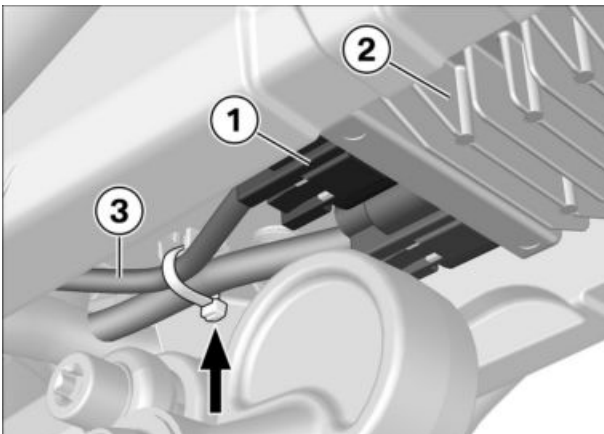

- Work connector **(1)** with cable **(3)** through to the rear.
- Connect connector **(1)** with voltage regulator **(2)**.
- Secure the cable strap **(arrow)**.

# 81

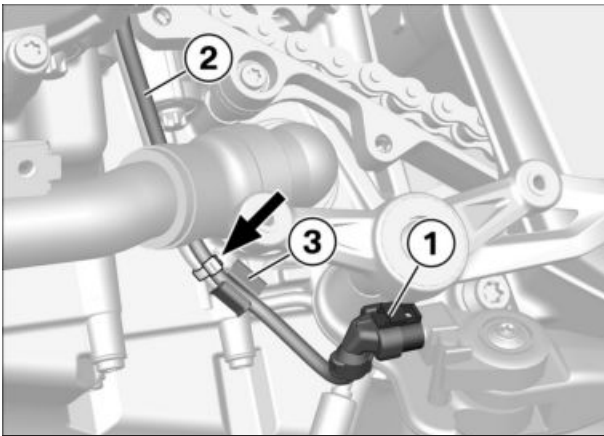

## ▶ Connecting connector for side-stand switch

- Connect connector **(1)** for side-stand switch.
- Secure the clutch cable **(2)** in holder **(3)**.
- Secure the cable strap **(arrow)**.



# 82

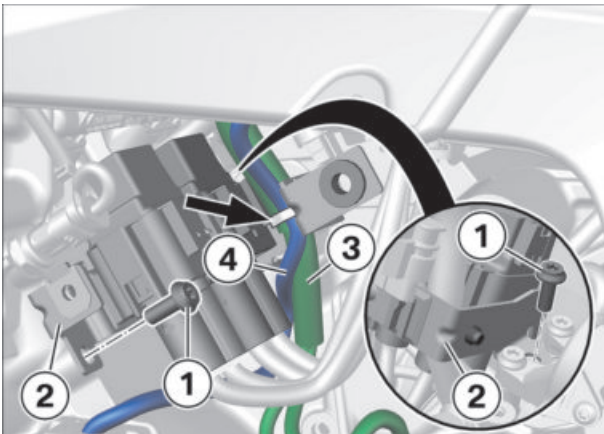

## ▶ Securing the relay holder

- Fit relay holder **(2)**.
- Install screws **(1)**.

🔧 Tightening torques		
Relay carrier to engine		
M6 x 16	8 Nm	

- Secure wiring harness **(3)** for Gear Shift Assistant and side-stand switch and cable **(4)** for alternator with cable strap **(arrow)**.



# 83

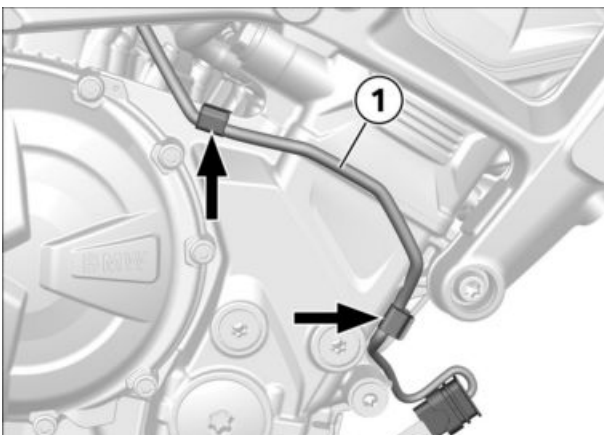

## ▶ Securing engine wiring harness

- Secure wiring harness **(1)** in holders **(arrows)**.

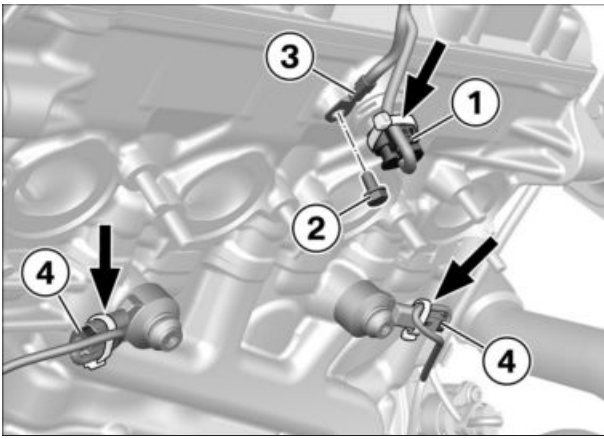

- Connect connector for knock sensors **(4)**.
- Fit ground connection **(3)** and install bolt **(2)**.

Tightening torques		
Engine wiring harness (earth) to cylinder head		
M5 x 10	5 Nm	

- Connect connector **(1)** for camshaft sensor.
- Close the cable strap **(arrows)**.

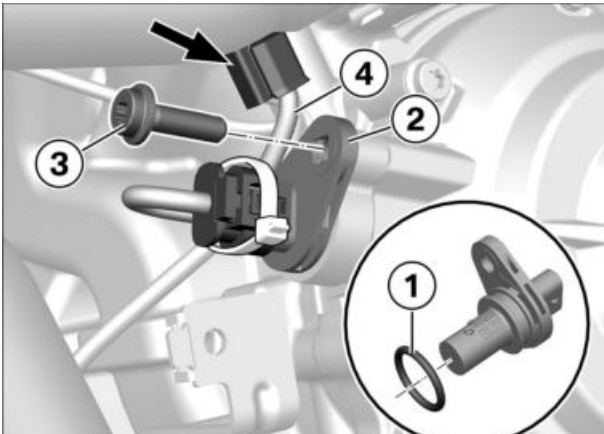

- Check O-ring **(1)** and renew if required.
- Lubricate the O-ring **(1)** with engine oil.
- Secure crankshaft sensor **(2)**.
- Install bolt **(3)**.

Tightening torques		
Crankshaft sensor on engine housing cover		
M6 x 20, Renew screw	5 Nm	

- Secure the cable **(4)** in the holder **(arrow)**.

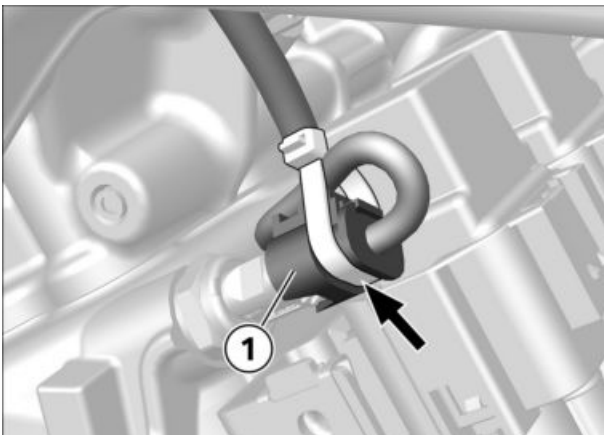

- Connect connector **(1)** for coolant temperature sensor.
- Secure the cable strap **(arrow)**.

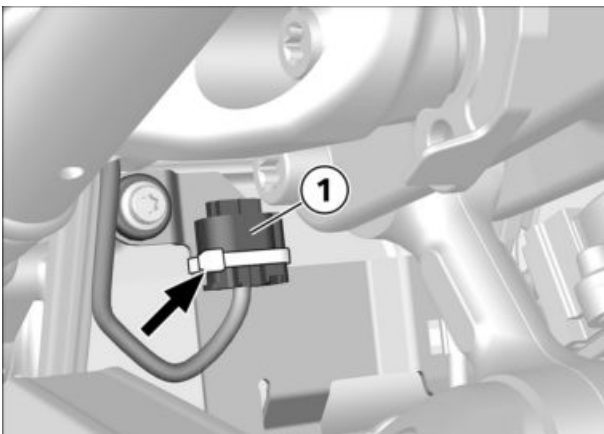

- Fit connector **(1)** and secure cable strap **(arrow)**.

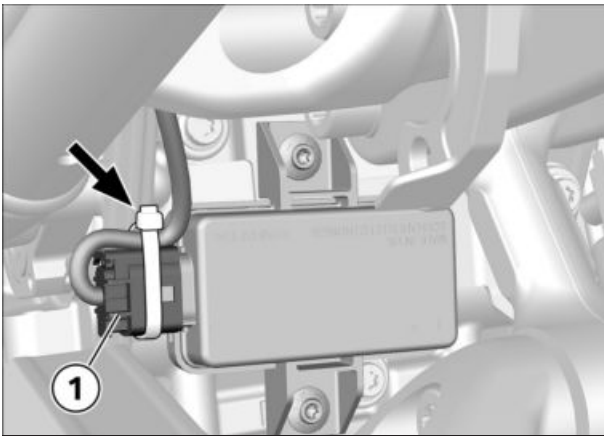

- with tyre pressure control (RDC)<sup>OE</sup> (0530)
- Connect connector **(1)** for RDC control unit.
- Secure the cable strap **(arrow)**.◇

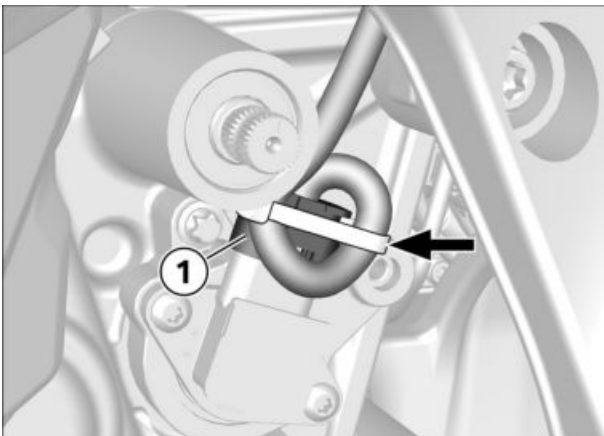

- Connect and lock connector **(1)** for transmission potentiometer.
- Secure the cable strap **(arrow)**.

## 84

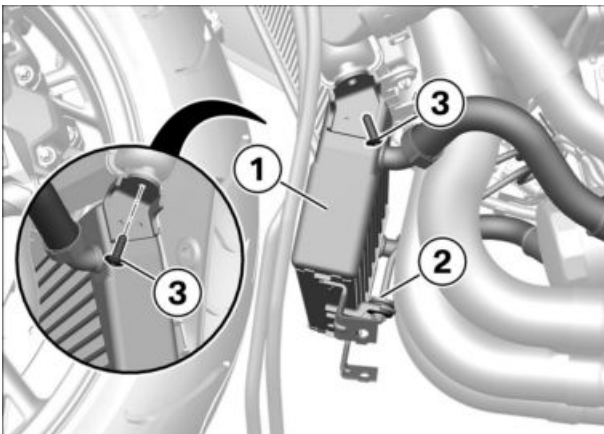

### ► Secure the oil cooler

- Clean the threads.
- Make sure that the oil cooler **(1)** is fastened on holder **(2)**.
- Fit oil cooler **(1)** and install bolts **(3)**.

🔧 Tightening torques		
Oil cooler to radiator		
M5 x 16, Renew screw Thread-locking compound (micro-encapsulated)	5 Nm	

# 85

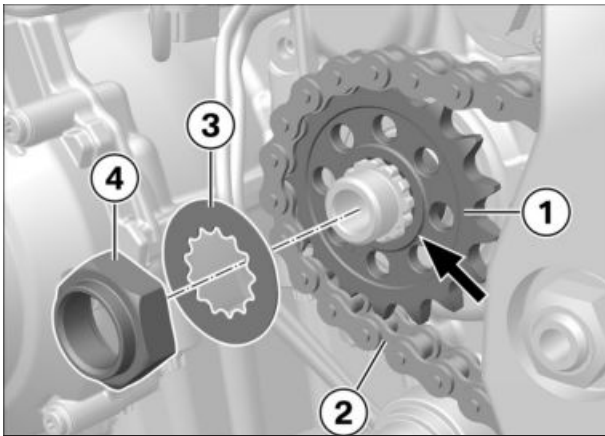

## ► Installing pinion

- Fit pinion (1), with low shoulder (arrow) outward, and work into chain (2).
- Install pinion (1).
- Install new locking washer (3) and nut (4), do not tighten.

# 86

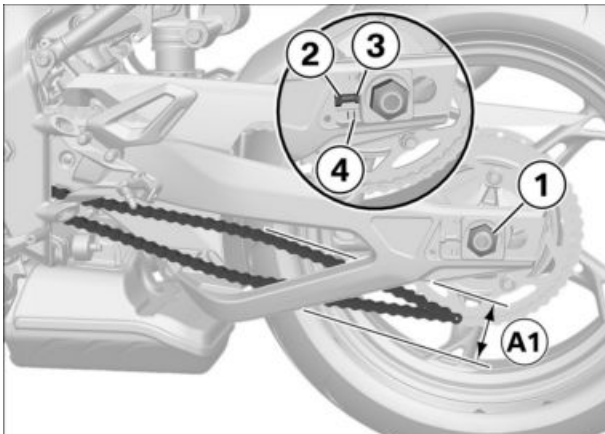

## ► Adjusting chain sag

### ATTENTION

**Rear wheel skewed at a slight angle because tensioning screws not adjusted to same setting**

Accelerated wear at rear wheel and chain drive

- Make sure that the rear wheel is aligned to track correctly (same scale reading on both sides of the rear wheel swinging arm).
- Adjust chain tension (A) with tensioning screw (3) on left and right, making sure the toe adjustment (same scale value (4) on both sides of the rear wheel swinging arm) is correct.

 Technical data			
Chain deflection	Motor-cycle with no weight applied, supported on its side stand	45...50 mm	

- Tighten lock nuts (2) on left and right, counter-holding tensioning screws (3).

 Tightening torques		
Locknut of the final-drive chain tensioning screw		
M8	19 Nm	

- Tighten the nut (1).

🔧 Tightening torques		
Rear quick-release axle in swinging arm		
M24 x 1.5 Thread-locking compound (mechanical)	125 Nm	

## 87

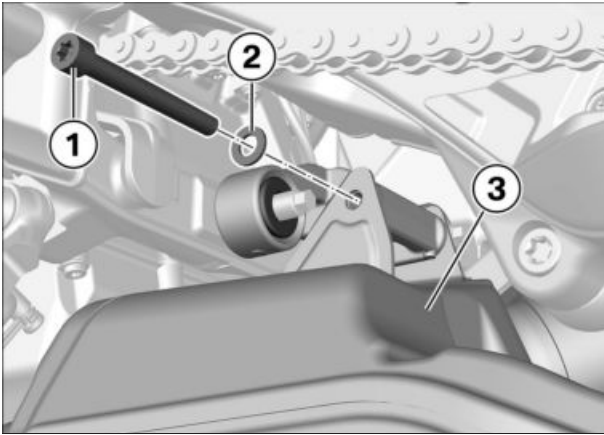

### ► Securing exhaust manifold, rear

- Secure exhaust manifold (3) with bolt (1) and washer (2).

🔧 Tightening torques		
Exhaust manifold to holder		
M8 x 70, Renew screw Thread-locking compound (micro-encapsulated)	18 Nm	

## 88

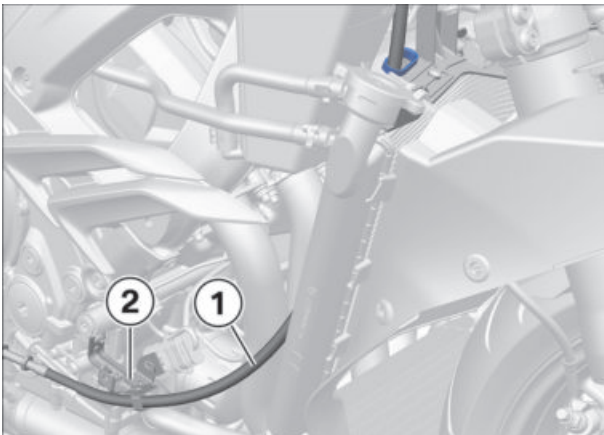

### ► Securing the clutch cable

- Secure the clutch cable (1) in holder (2).

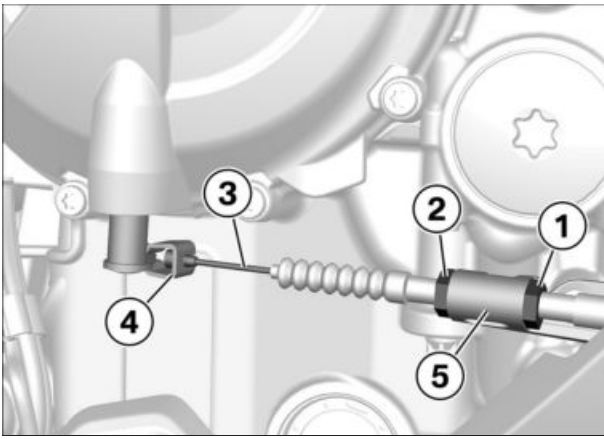

- Secure the clutch cable (3) in holder (5).
- Attach clutch cable (3) in lever (4).
- Hand-tighten adjusting nuts (1) and (2).

## 89

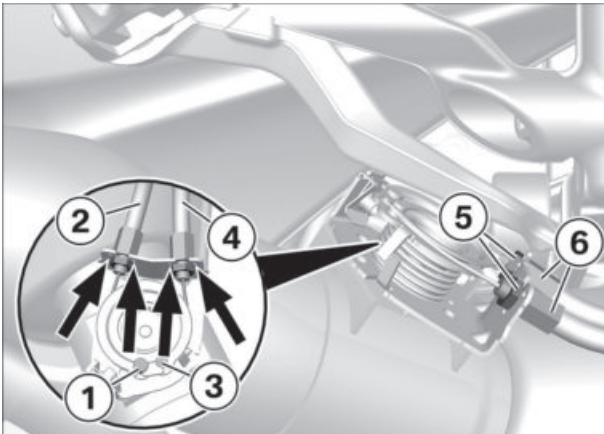

### ► Securing Bowden cables to exhaust-flow control valve

- Attach cable (1) and fit actuating cable (2).
- Attach cable (3) and position retention cable(4).
- Position nuts (5) between stops (arrows).
- Tighten bolts (6) and counter-hold nuts (5) where needed.

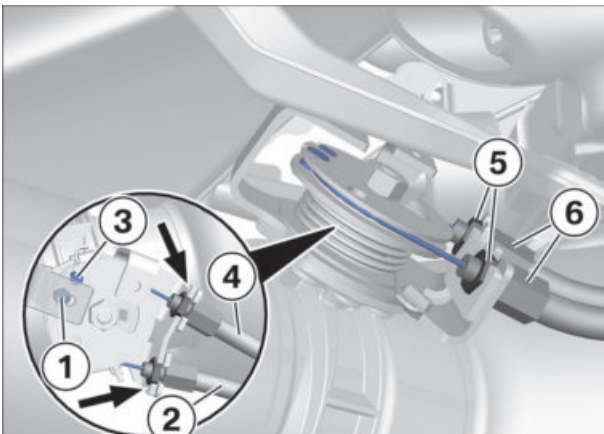

– with M titanium exhaust system<sup>OE</sup> (019H)

- Attach cable (1) and fit actuating cable (2).
- Attach cable (3) and position retention cable(4).
- Position nuts (5) in stops (arrows).
- Tighten bolts (6) and counter-hold nuts (5) where needed.◊

# 90

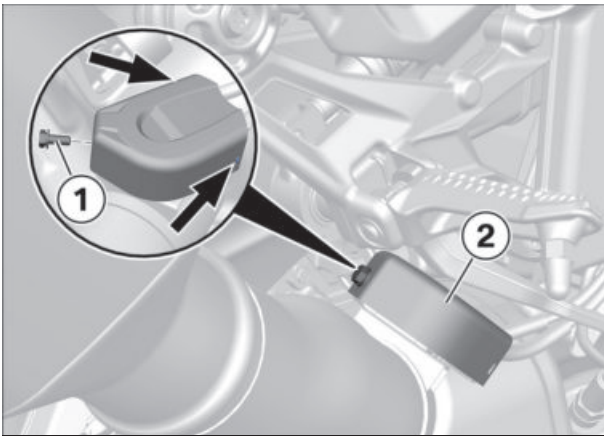

## ► Installing cover of exhaust-flow control valve

- Install cover (2) in locators (arrows).
- Install bolt (1).

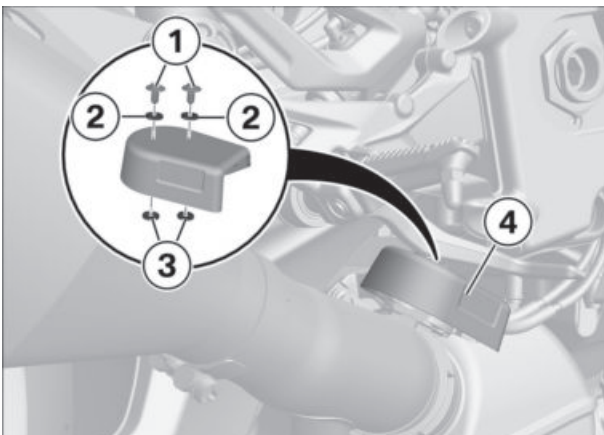

– with M titanium exhaust system<sup>OE</sup> (019H)

- Position cover (4) with preassembled bolts (1) and washers (2) and (3).
- Install screws (1).◇



# 91

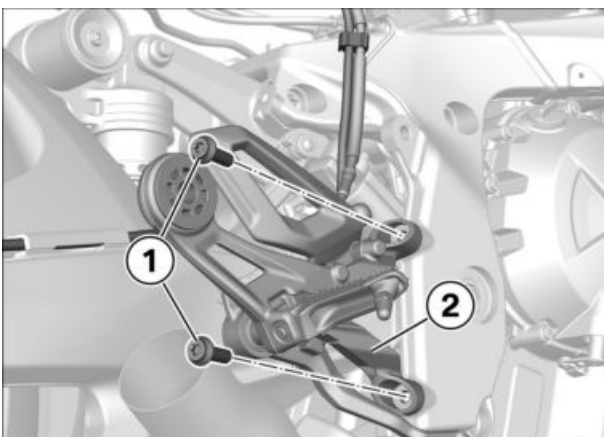

## ► Secure the right footrest plate

- Hold footrest plate (2) in position and install screws (1).



### Tightening torques

#### Front footrest holder to main frame

M8 x 25

19 Nm



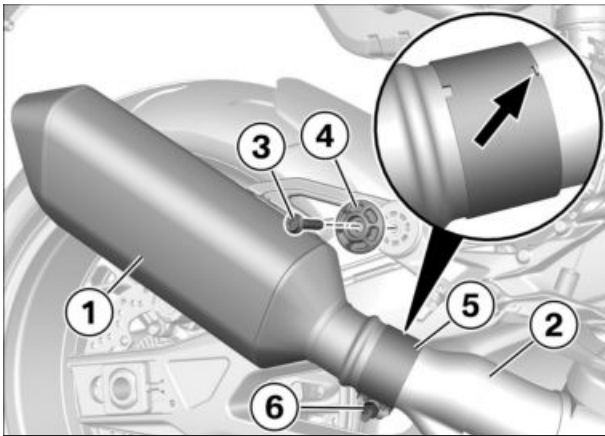

► **Installing silencer**

- Push silencer **(1)** onto front silencer **(2)**.
- Install screw **(3)** and shaped washer **(4)**.

🔧 <b>Tightening torques</b>		
<b>Silencer to footrest system</b>		
M8 x 40	19 Nm	

- Position clamp **(5)** with the recess in the lug **(arrow)**.
- Tighten the nut **(6)**.

🔧 <b>Tightening torques</b>		
<b>Clamping collar for rear silencer</b>		
M8	24 Nm	

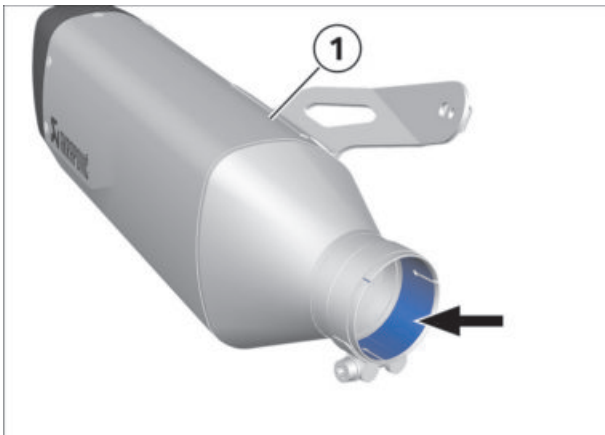

– with M titanium exhaust system<sup>OE</sup> (019H)

or

– with M Sports silencer<sup>OE</sup> (019G)

- Lightly lubricate inner surface **(arrow)** of silencer **(1)**.

🔧 <b>Lubricant</b>	
Optimoly TA	18 21 9 062 599

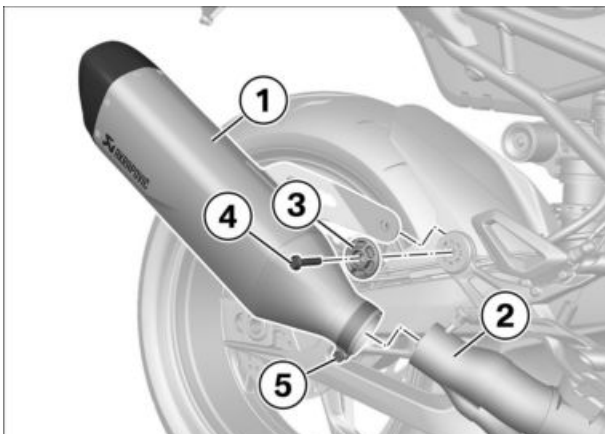

– with M titanium exhaust system<sup>OE</sup> (019H)

or

– with M Sports silencer<sup>OE</sup> (019G)

- Connect silencer **(1)** to exhaust pipe of front silencer **(2)**.
- Position the shaped washer **(3)** and install the screw**(4)**, do not tighten.
- Tighten clamping collar **(5)** hand-tight.◊

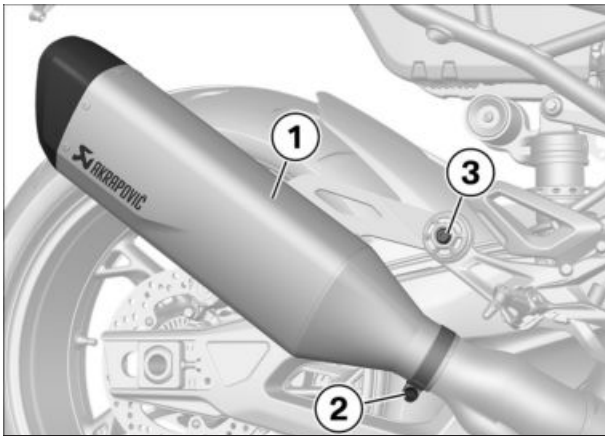

- with M titanium exhaust system<sup>OE</sup> (019H)
- or
- with M Sports silencer<sup>OE</sup> (019G)
- Align silencer **(1)**.
- Tighten clamping collar **(2)**.

Tightening torques		
Clamping collar for rear silencer		
M8	14 Nm	

- Tighten the screw **(3)**.

Tightening torques		
Silencer to footrest system		
M8 x 40	19 Nm	

## 93

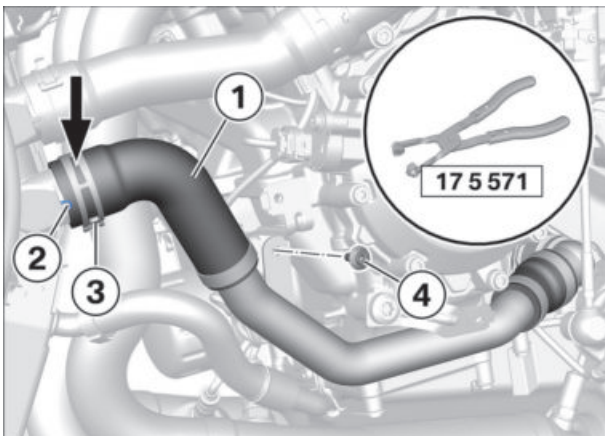

### ► Filling cooling system

- Push on coolant hose **(1)**.
- » Lug **(2)** engages in recess of coolant hose **(1)**.
- Secure clamp **(3)** using pliers (17 5 571) and align to mark **(arrow)**.
- Install bolt **(4)**.

Tightening torques		
Coolant line to bracket		
M5 x 16	5 Nm	

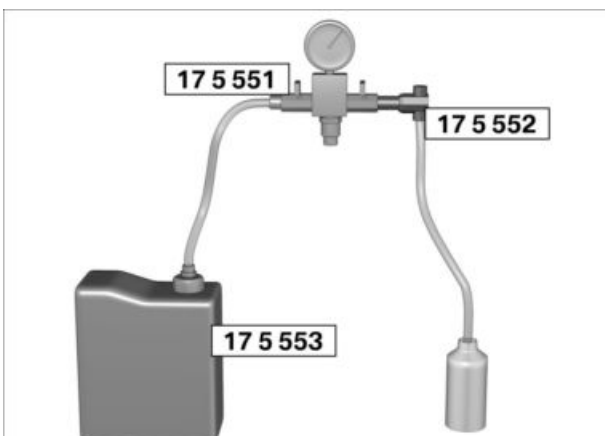

### ▷ Preparing and priming radiator filler for cooling system

- Fill canister (17 5 553) with an adequate quantity of coolant.

Technical data		
Coolant, total capacity		2.95 l
	General consumable (Antifreeze and corrosion inhibitor)	

- Connect canister (17 5 553), venturi nozzle (17 5 552) and distributor unit (17 5 551).
- Put the end of the drain hose of venturi nozzle (17 5 552) into a suitable container.

### **ATTENTION**

#### Connecting compressor to distributor unit of filler adapter with compressed-air valve open

Damage to pressure meter due to pressure peaks

- Make sure the valves are closed when you connect the compressor to the distributor unit.

- Connect the compressor to the venturi nozzle (17 5 552).

 <b>Technical data</b>			
Minimum requirement, compressor	Print	min 8 bar	
	Delivery rate	min 125 l/ min	

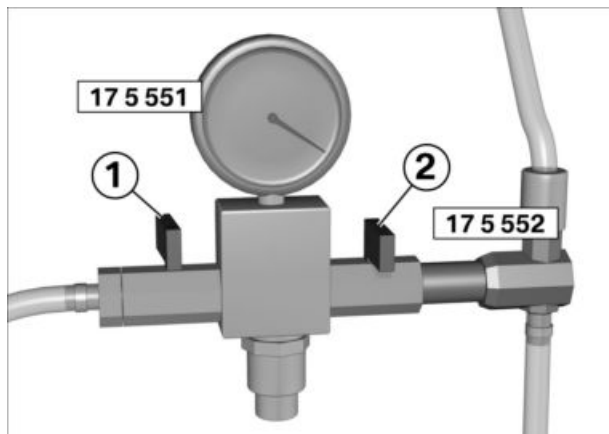

- Begin by fully opening coolant cock **(1)** and then fully opening negative-pressure cock **(2)** of distributor unit (17 5 551).
  - » Coolant is drawn in by vacuum from the tank.
- Draw in coolant until the hose to distributor unit (17 5 551) is full of **bubble-free** coolant.
- Close coolant cock **(1)** and negative-pressure cock **(2)**.
- Disconnect the compressor from venturi nozzle (17 5 552).

△

### ▷ Connecting radiator filler to cooling system

#### Requirement

The coolant canister must be higher than the motorcycle's radiator.

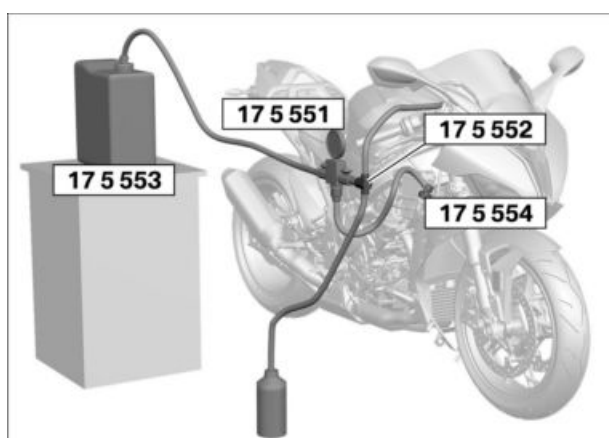

- Position coolant canister (17 5 553) on a higher level.
- Secure the preassembled radiator filler in position at the motorcycle.
- Connect radiator port (17 5 554) to distributor unit (17 5 551) and radiator filler neck.
- Put the end of the drain hose of venturi nozzle (17 5 552) into a suitable container.
- Prepare the compressor.

 <b>Technical data</b>			
Minimum requirement, compressor	Print	min 8 bar	
	Delivery rate	min 125 l/ min	

△

### ▷ Evacuating cooling system

#### ATTENTION

##### Connecting compressor to distributor unit of filler adapter with compressed-air valve open

Damage to pressure meter due to pressure peaks

- Make sure the valves are closed when you connect the compressor to the distributor unit.

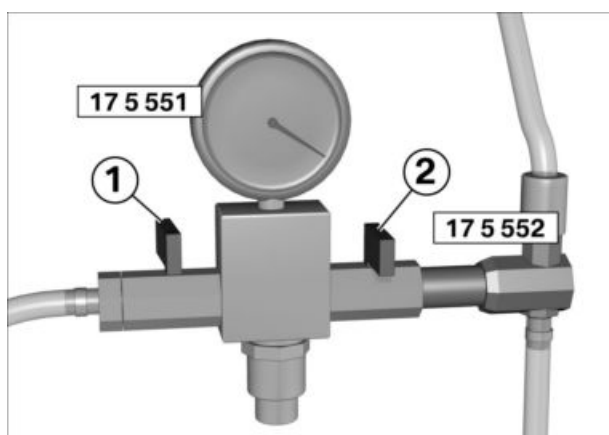

- Connect the compressor to the venturi nozzle (17 5 552).
- Open negative-pressure cock **(2)** of distributor unit (17 5 551).
  - » A vacuum builds up in the system.

- Evacuate the cooling system until the requisite negative pressure is established and the needle of the pressure gauge is steady.

 <b>Technical data</b>			
Requisite vacuum for filling the cooling system		min -0.8 bar	

- Close negative-pressure cock **(2)**.
- Disconnect the compressor from venturi nozzle (17 5 552).
- Observe the needle of the pressure gauge of distributor unit (17 5 551) for a time and check that the partial vacuum in the cooling system does not rise to ambient pressure.

 <b>Technical data</b>			
Requisite vacuum for filling the cooling system		min -0.8 bar	

- Slowly open coolant cock **(1)** until it is fully open.
  - » Coolant flows into the cooling system.
- When the level of fluid in the canister (17 5 553) **ceases to drop** and the vacuum corresponds to ambient pressure, shut coolant cock **(1)**.

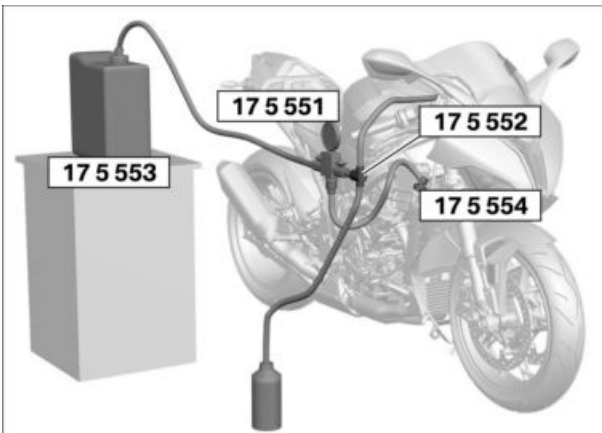

△

#### ▷ Disconnecting radiator filler from radiator

- Disconnect the radiator filler from the radiator and remove it from the vehicle.

△

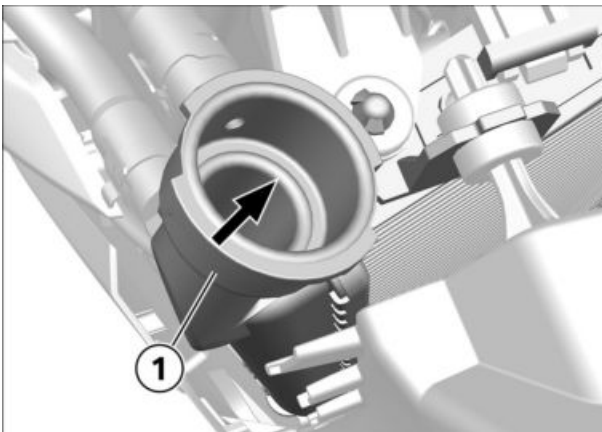

- Check the coolant level; top up if necessary. (Cooling system must be filled with coolant up to the lower edge **(arrow)** of coolant filler neck **(1)**.)

 <b>General consumable</b>	
Antifreeze and corrosion inhibitor	83 51 2 445 463

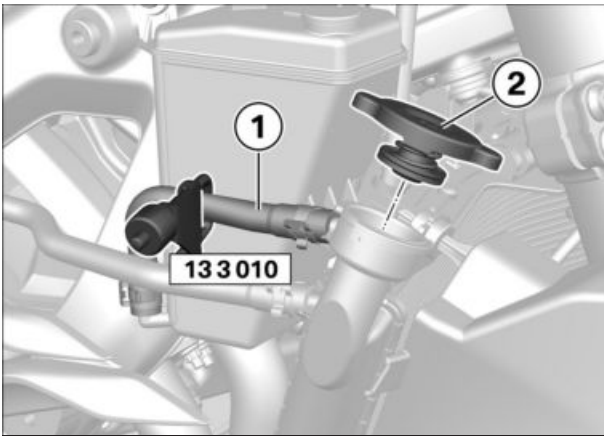

▷ **Install the radiator cap**

- Install the radiator cap **(2)**.
- Remove hose clip (13 3 010) from overflow hose **(1)**.



**94**

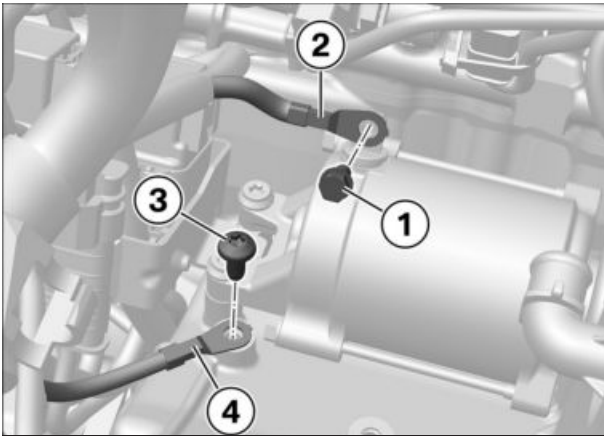

▶ **Connecting starter motor**

- Fit grounding cable **(4)** and install screw **(3)**.

🔧 <b>Tightening torques</b>		
<b>Wiring harness (earth) to crankcase</b>		
M6 x 12	8 Nm	

- Fit the positive wire for the starter motor **(2)** and install the bolt **(1)**.

🔧 <b>Tightening torques</b>		
<b>Wiring harness (positive wire) to starter motor</b>		
M5 x 10	3 Nm	

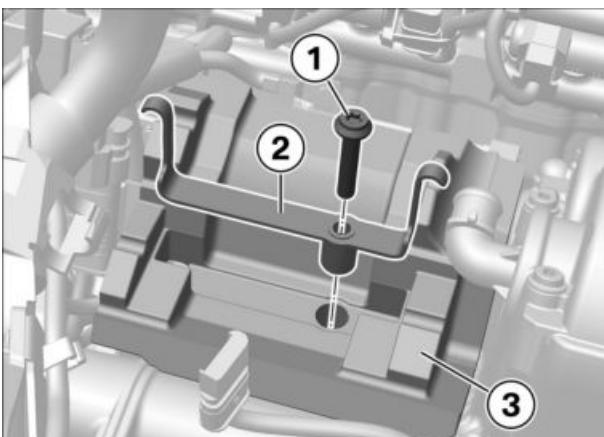

- Install holders **(3)** and retaining brackets **(2)**.
- Install bolt **(1)**.



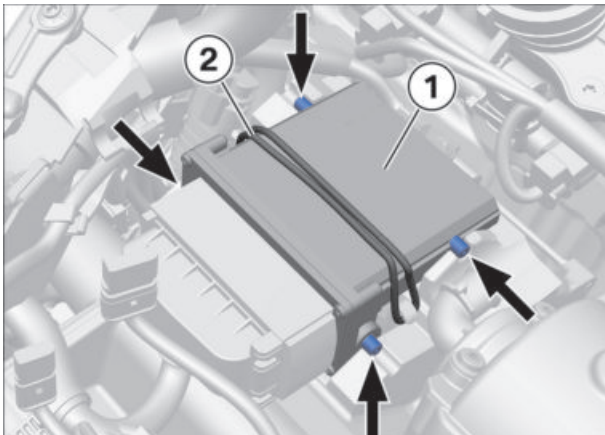

– with Dynamic Damping Control (DDC)<sup>OE</sup> (0223)

► **Securing control unit for electronic suspension adjustment**

- Fit control unit **(1)** observing locators **(arrows)**.
- Install the O-ring **(2)**.◊

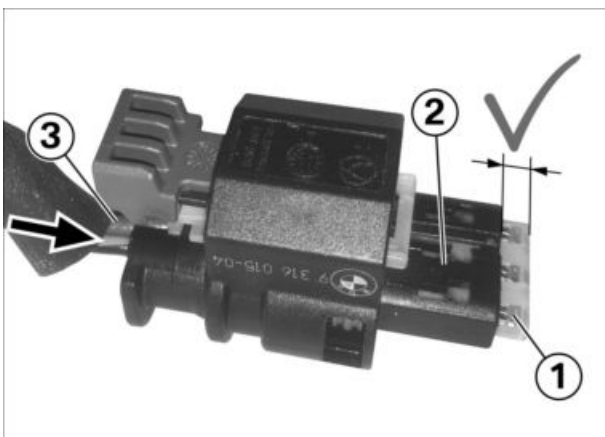

► **Connecting engine wiring harness on cylinder head cover**

▷ **Information for connecting vibration-resistant connectors**

- Check if the contact carrier **(1)** protrudes significantly from the connector housing **(2)**.
- If necessary, hold down the connector housing **(2)** and slide contact carrier from the rear at the cable inlet **(3)** toward the front until the contact carrier **(1)** is visible

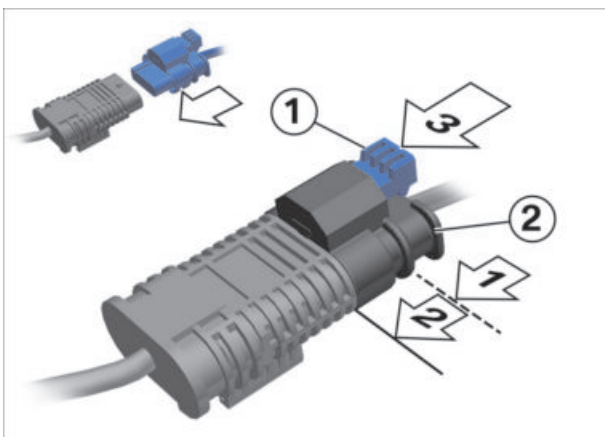

- Ensure that the release tab **(1)** is unlocked.
- Slide connector **(2)** in direction of arrow **(arrow 1)**.
  - » The connector **(2)** engages audibly.
- Slide connector **(2)** in direction of arrow **(arrow 2)** further.
  - » The connector **(2)** engages audibly.
- Slide locking tab **(1)** in direction of arrow **(arrow 3)**.
  - » The locking tab **(1)** engages audibly.



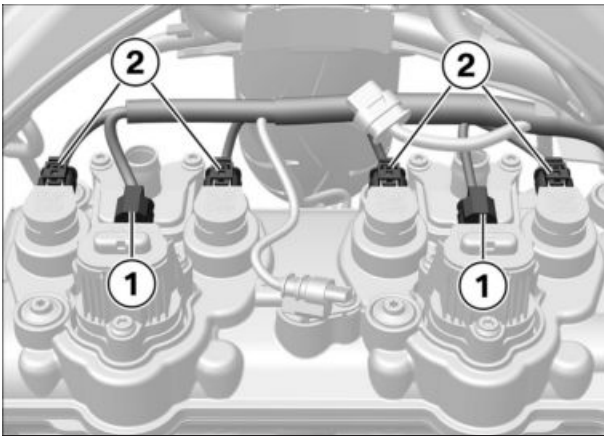

- Connect connectors **(1)** for switching cam adjusters.
- Connect connector **(2)** for direct ignition coils.

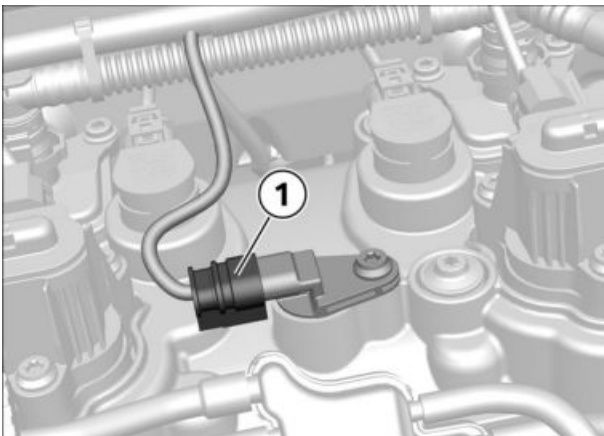

- Connect connector for switching cam sensor **(1)**.

## 97

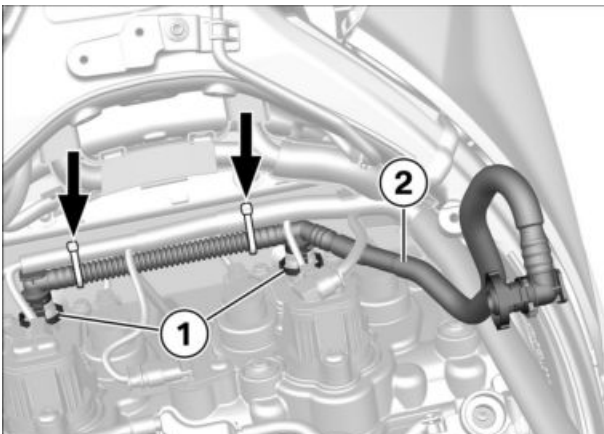

### ► Installing secondary air system line

- Feed in and fit secondary air system line **(2)**.
- Slide on hose connections **(1)** for secondary air system until the locks engage with an audible click.
- Close the cable strap **(arrows)**.

## 98

### ► Installing throttle-valve assembly

#### NOTICE

Connect the connector of the throttle-valve assembly first, then install throttle-valve assembly; otherwise, there is a risk of damaging the connectors.

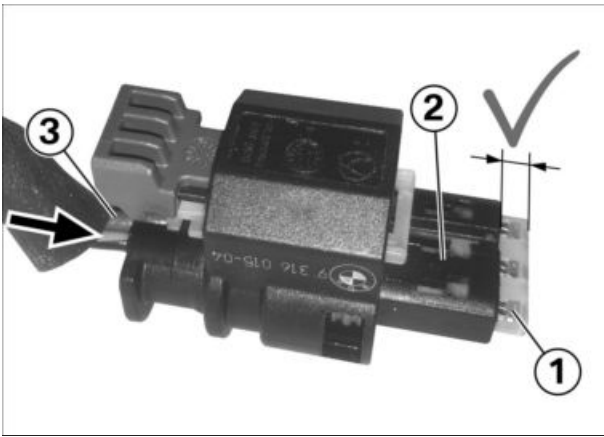

▷ **Information for connecting vibration-resistant connectors**

- Check if the contact carrier **(1)** protrudes significantly from the connector housing **(2)**.
- If necessary, hold down the connector housing **(2)** and slide contact carrier from the rear at the cable inlet **(3)** toward the front until the contact carrier **(1)** is visible

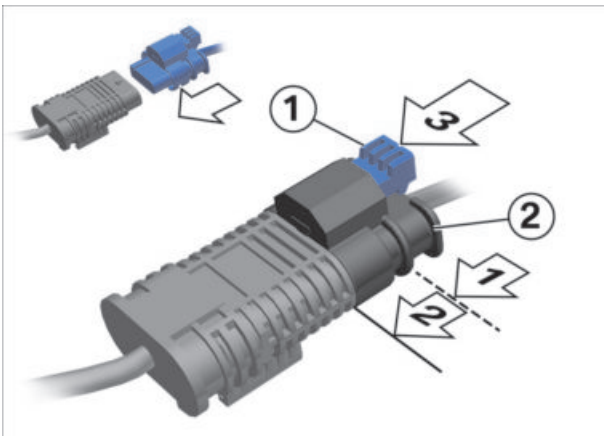

- Ensure that the release tab **(1)** is unlocked.
- Slide connector **(2)** in direction of arrow **(arrow 1)**.
  - » The connector **(2)** engages audibly.
- Slide connector **(2)** in direction of arrow **(arrow 2)** further.
  - » The connector **(2)** engages audibly.
- Slide locking tab **(1)** in direction of arrow **(arrow 3)**.
  - » The locking tab **(1)** engages audibly.

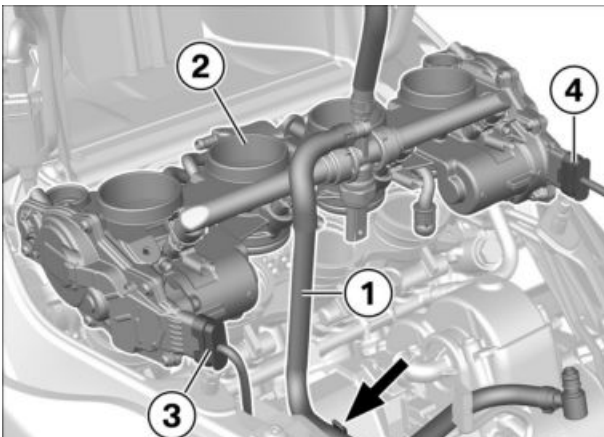

◁

- Remove cap from intake ducts.
- Position throttle valve assembly **(2)**, connect connector **(3)** and **(4)**.
- Secure fuel line **(1)** in holder **(arrow)**.

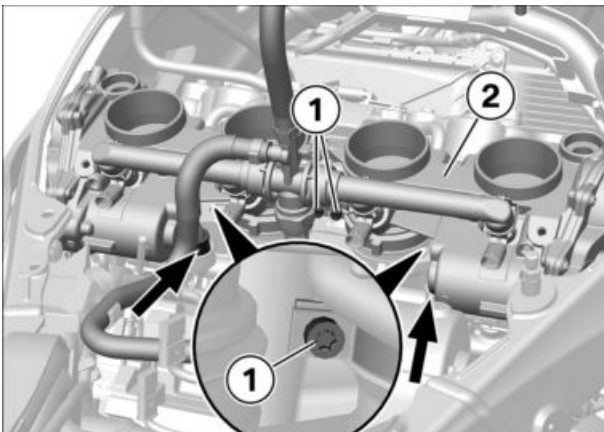

- Lubricate connecting piece of throttle valve assembly **(2)** and connections **(arrows)** for bypass lines.

 <b>Installation tool</b>	
Silicone spray	83 19 2 208 609

- Install throttle valve assembly **(2)** while observing connections **(arrows)** for bypass lines.
- Tighten screw clamp **(1)**.

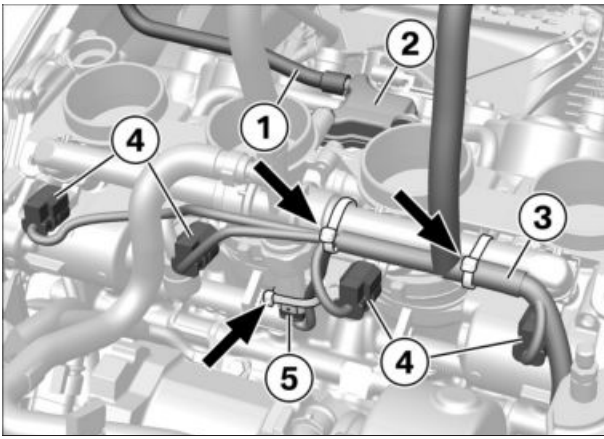

- Connect connector **(5)** for fuel pressure sensor.
- Connect connector **(4)** for fuel injectors.
- Position wiring harness **(3)** and fasten cable ties **(arrows)**.
- Connect hose **(1)** of tank vent valve to distributor **(2)**.

99

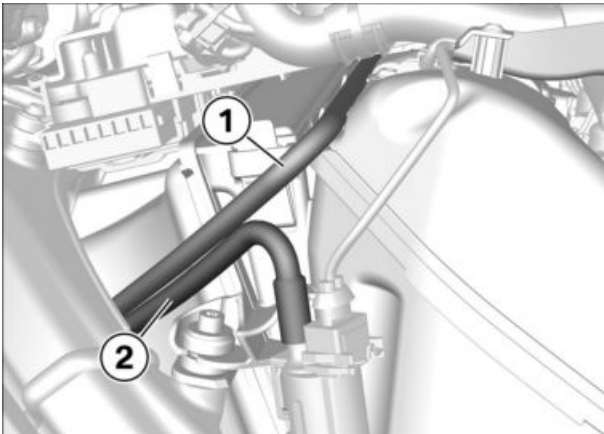

► **Installing rear air intake duct**

- When installing the rear air intake duct, make sure the hoses are routed correctly.
  - Hose **(1)** to carbon filter
  - Hose **(2)** to tank vent valve

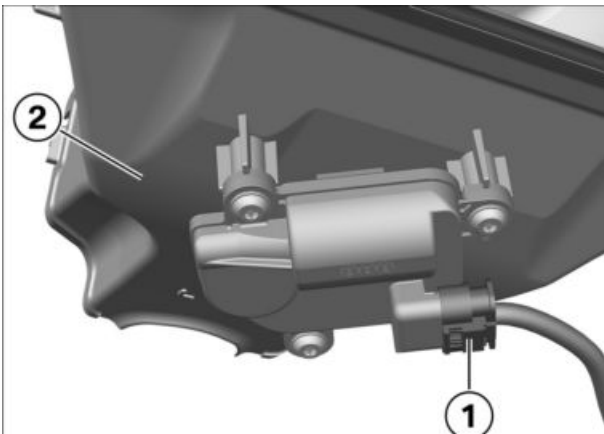

- Fit air intake duct **(2)** and connect connector **(1)**.

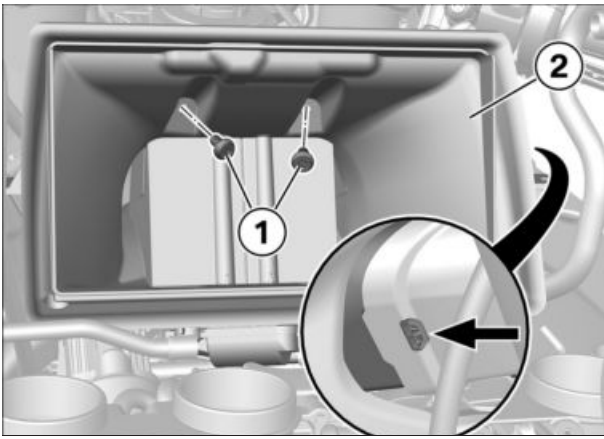

- Install air intake duct **(2)**, and let left and right locators (**arrow**) engage for this purpose.
- Install screws **(1)**.

Tightening torques		
<b>Rear air guide to frame</b>		
M6 x 12	8 Nm	

## 100

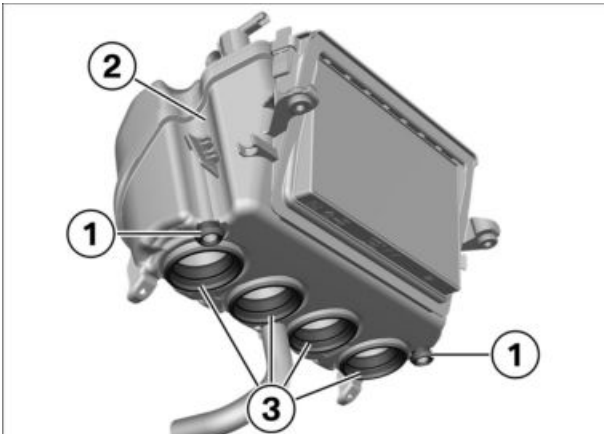

### ► Install the intake air silencer

- Make sure that rubber grommets **(1)** for idle controller are installed on intake silencer **(2)**.
- Lubricate rubber grommets **(1)** and intake rubbers **(3)**.

Installation tool	
Tyre-fitting paste	81 22 0 433 046

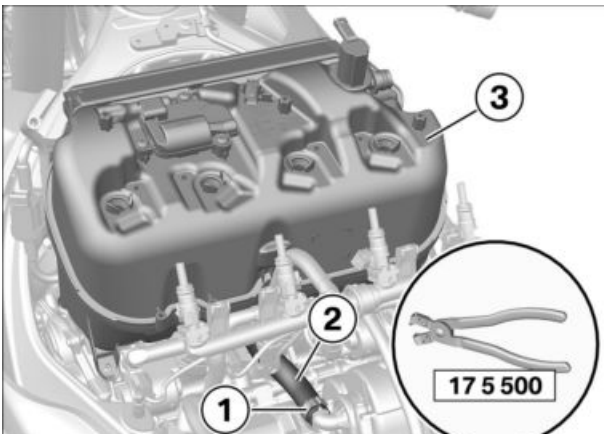

- Fit intake silencer **(3)** and feed in hose **(2)** for crankcase ventilation.
- Install intake silencer **(3)**.

### **NOTICE**

When installing the intake silencer make sure that the carb mount rubbers are not pushed into the intake silencer. Check the position of the carb mount rubbers again after installation and correct where required.

- Connect hose **(2)** for crankcase ventilation with clamp **(1)**.
- Align clamp **(1)** with mark and secure with pliers (17 5 500).

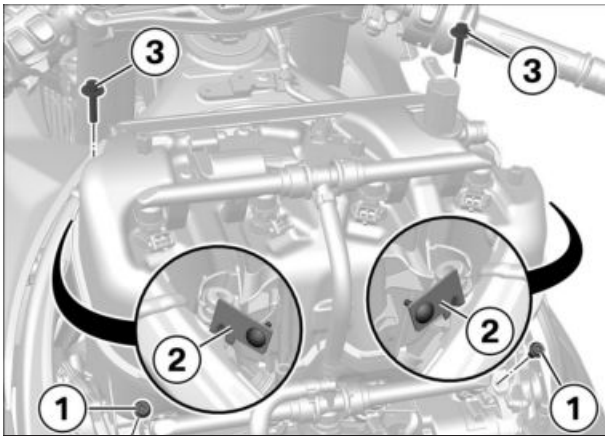

- Install screws **(1)**.

🔧 <b>Tightening torques</b>		
<b>Intake silencer to throttle-valve assembly</b>		
M6 x 12	6 Nm	

- Fit holder **(2)** and install bolts **(3)**.

🔧 <b>Tightening torques</b>		
<b>Intake silencer to frame</b>		
M6 x 30	8 Nm	

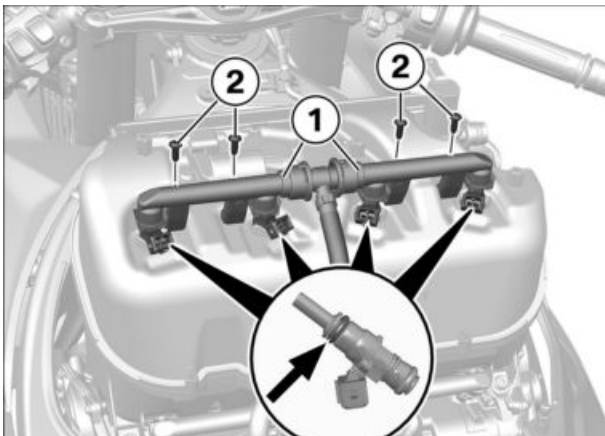

- Check O-rings **(arrow)**; replace if necessary.
- Lubricate O-rings **(arrow)**.

🔧 <b>Installation tool</b>	
Silicone spray	83 19 2 208 609

- Secure fuel injection pipe with injector nozzles **(1)**.
- Install screws **(2)**.

🔧 <b>Tightening torques</b>		
<b>Fuel injection pipe to intake silencer</b>		
TS5 x 14	3 Nm	

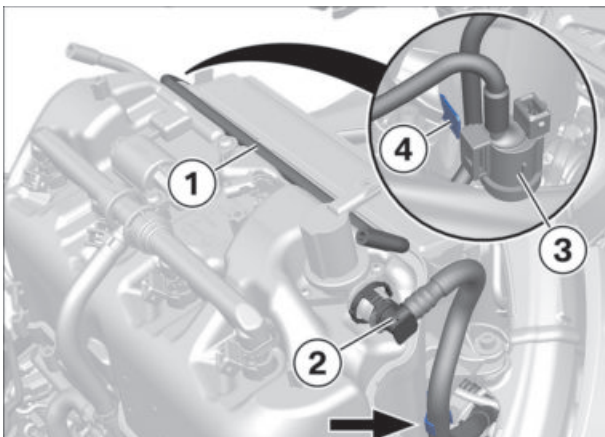

- Secure tank vent valve **(3)** to holder **(4)**.
- Slide on hose connection **(2)** for secondary air system until it locks with an audible click and secure hose in holder **(arrow)**.
- Secure hose **(1)**.

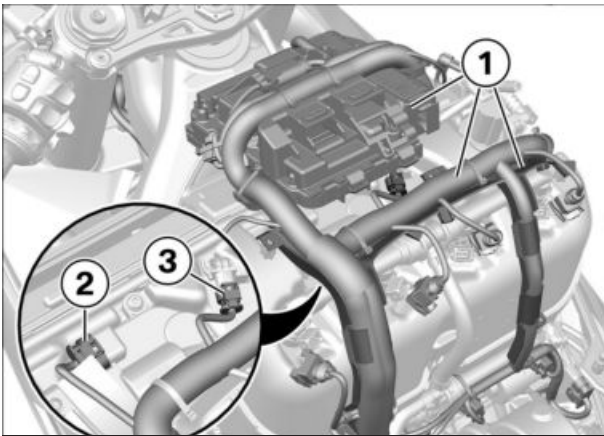

## ► Attaching engine control unit with wiring harness

- Place the control unit **(1)** with cable duct and wiring harness toward the front.
- Connect connector **(3)** for the intake air temperature sensor.
- Connect connector **(2)** for DISA servomotor.
- Position control unit **(1)** with cable duct and wiring harness.

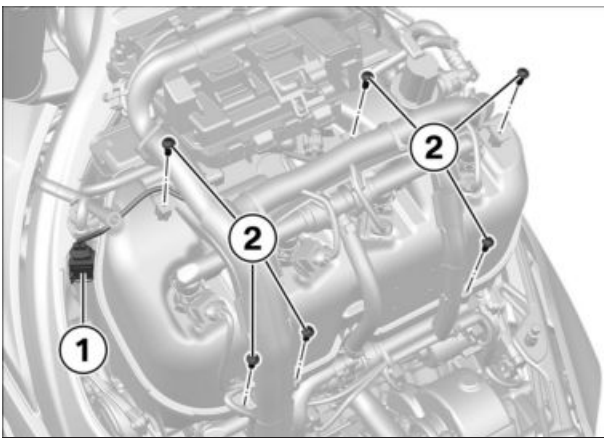

- Install screws **(2)**.
- Connect connector **(1)** for the tank vent valve.

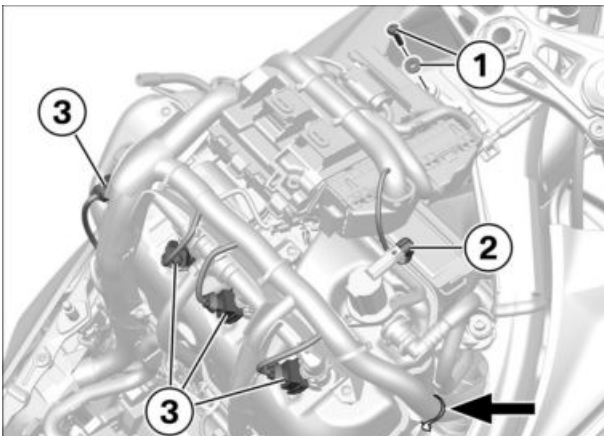

- Connect connector **(2)** for secondary air control valve and connector **(3)** for fuel injectors.
- Install bolt with contact disc **(1)**.

### Tightening torques

#### Engine control unit bracket to frame

M5 x 25	5 Nm	
---------	------	--

- Install cable straps **(arrow)** , do not tighten.

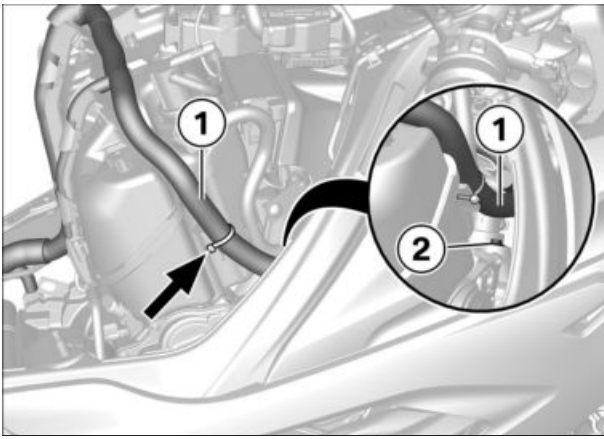

## ATTENTION

### Improper routing of wiring harness and contact to screw connection of cylinder head cover

Chafing at wiring harness

- Install wiring harness with distance to screw connection of the cylinder head cover.
- Pull main wiring harness **(1)** up during routing until it no longer rests against the bolt **(2)** for the cylinder head cover and it is routed with a gap.
- Secure the cable strap **(arrow)**.

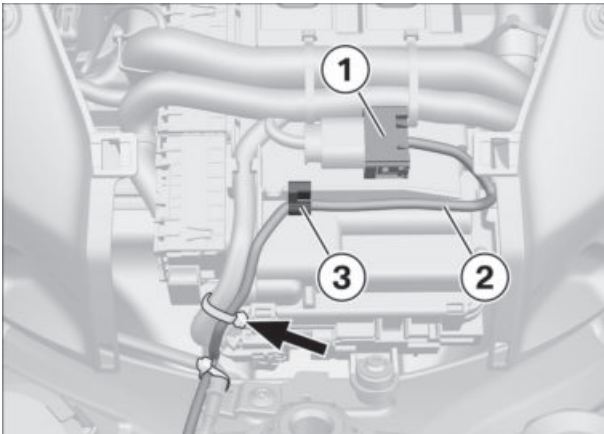

- Connect plug connection **(1)** for throttle grip.
- Secure the clutch cable **(2)** in holder **(3)**.
- Secure the cable strap **(arrow)**.

## 102

### ► Securing pinion

#### Requirement

Engage 1st gear and apply rear wheel brake.

- Tighten the nut **(2)**.

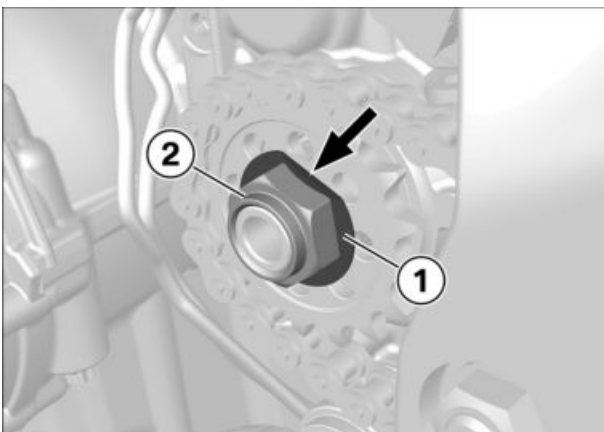

Tightening torques		
Pinion to transmission output shaft		
M24 x 1.5 secure with profile washer, Thread- locking compound (mechanical)	125 Nm	

- Using a suitable tool, bend up the tab **(arrow)** on locking washer **(1)**.

# 103

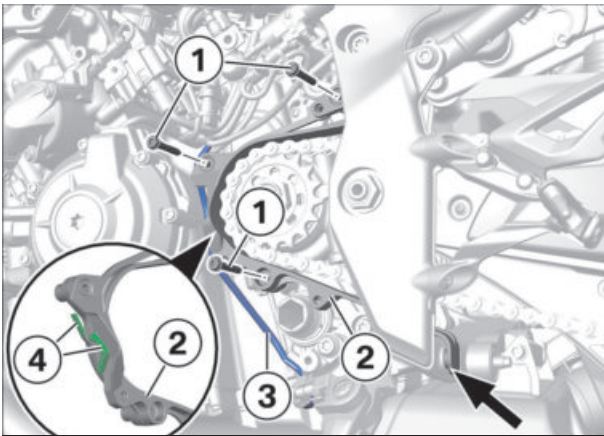

## ► Installing chain drop guard

- Route wiring harness (3) in cable routing (4) of chain failure protection (2).
- Install chain failure protection (2) and clip in mounting (arrow) on frame.
- Install screws (1).

Tightening torques		
Chain drop guard to engine		
M6 x 45	5 Nm	

# 104

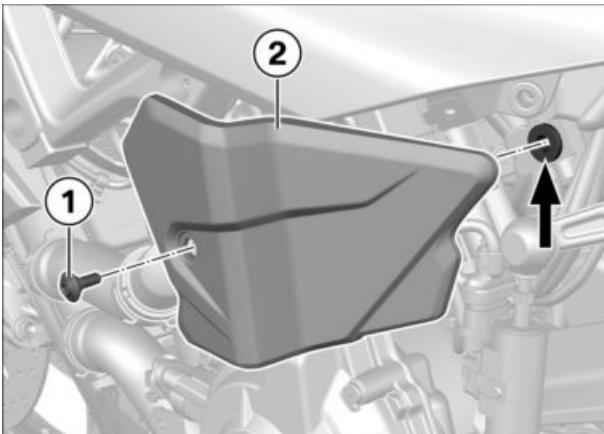

## ► Installing the trim for the relay

- Install trim (2) and secure in rubber grommet (arrow).
- Install bolt (1).

# 105

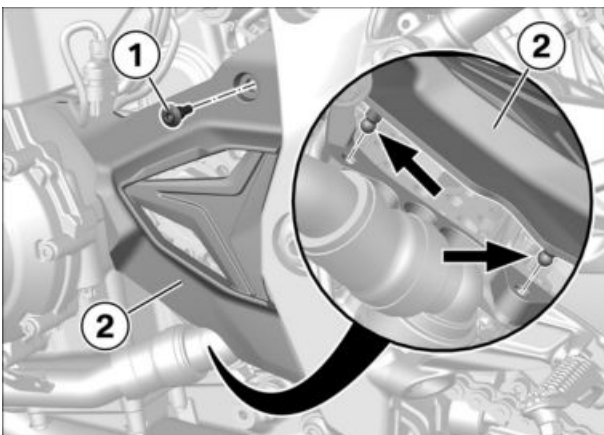

## ► Installing pinion cover

- Lubricate detent pins (arrows).

Installation tool	
Silicone spray	83 19 2 208 609

- Fit pinion cover (2) and let detent pins (arrows) engage.
- Install bolt (1).

Tightening torques		
Pinion cover to chain failure protection		
M5 x 20	2 Nm	

# 106

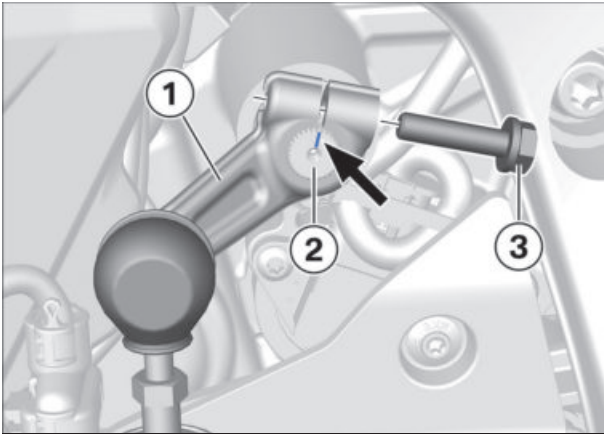

## ► Securing gear shift selector with Gear Shift Assistant

- Install gearshift lever (1) on gearshift shaft (2) while aligning gap with mark (arrow).
- Install bolt (3).

Tightening torques	
Gear selector lever to gearshift shaft	
M6 x 25	8 Nm

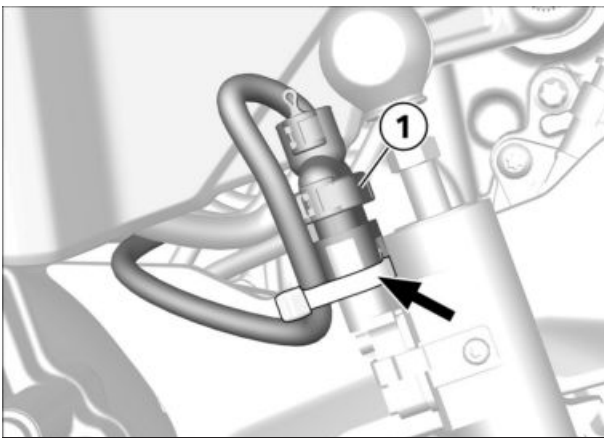

- Connect and lock connector (1) for Gear Shift Assistant.
- Secure the cable strap (arrow).

- Select neutral.

# 107



## ► Installing fuel tank

- Check O-ring of fuel delivery line (1) for damage; replace if necessary.

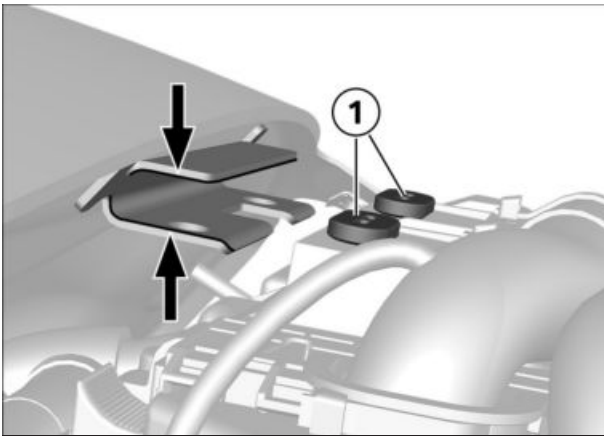

- While installing the fuel tank, ensure that the rubber retainer fits **(1)** in to the guide **(arrows)** of fuel tank.

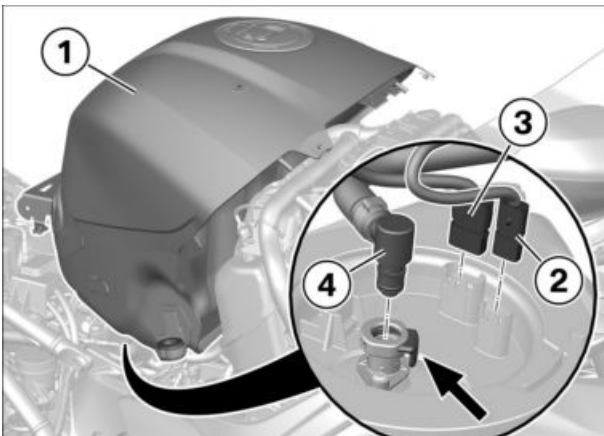

- Position fuel tank **(1)**.

### **ATTENTION**

#### **Application of force to close locked quick-action couplings**

Leak due to damaged O-rings

- Close the quick-action coupling of the fuel line only with the latch open/pressed.

- Push open the lock for fuel delivery line **(arrow)** and push fuel delivery line **(4)** into the bush with slight effort. Release the latch and check that the delivery line is correctly seated.

- Connect plug connection **(2)** for fuel level sensor and plug connection **(3)** for electric fuel pump.

- Position fuel tank **(1)**.

- Connect hoses **(1)** and **(2)**.

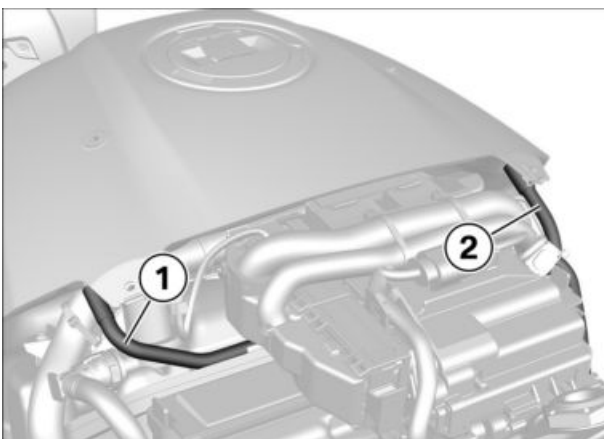

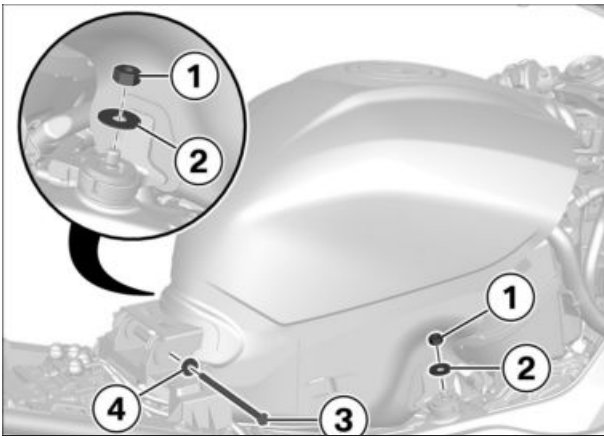

- Install bolt **(3)** with washer **(4)**.

🔧 Tightening torques		
Fuel tank to retaining bridge, rear		
M6 x 115	5 Nm	

- Install nuts **(1)** using washers **(2)**.

🔧 Tightening torques		
Fuel tank to frame		
M8	19 Nm	

# 108

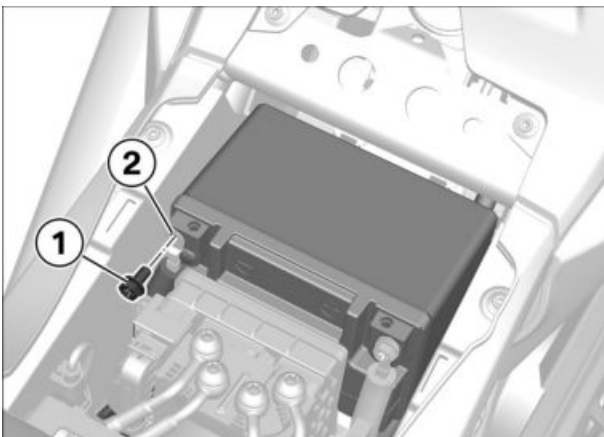

## ▶ Connect battery with vehicle

- Position wiring harness negative terminal **(2)** and install bolt **(1)**.

🔧 Tightening torques		
Wiring harness to battery		
M6 x 13,5	5 Nm	
M6 x 8	4.5 Nm	– with M Lightweight battery <sup>OE</sup> (053B)

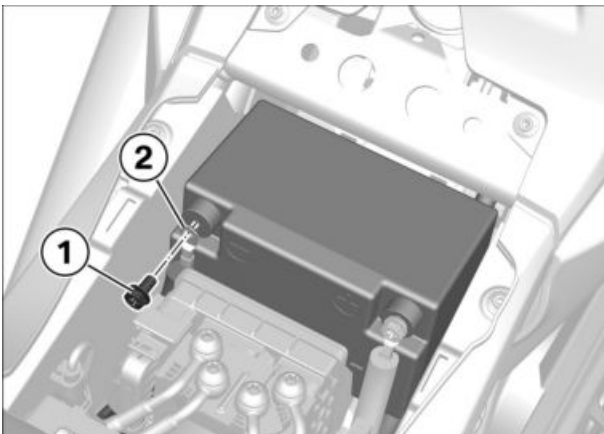

– with M Lightweight battery<sup>OE</sup> (053B)

- Position wiring harness negative terminal **(2)** and install bolt **(1)**.

🔧 Tightening torques		
Wiring harness to battery		
M6 x 13,5	5 Nm	
M6 x 8	4.5 Nm	– with M Lightweight battery <sup>OE</sup> (053B)

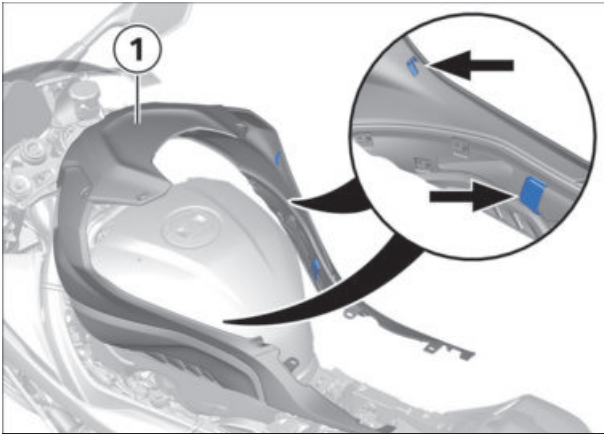

## ► Installing complete cover of fuel tank

- Fit complete cover of fuel tank **(1)**, attach locators (**arrows**) and install.

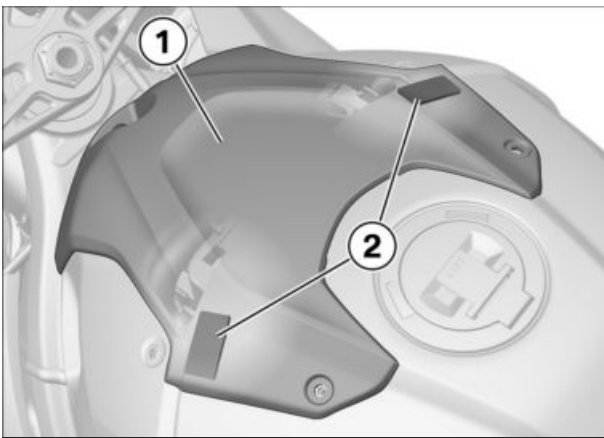

- Position centre fuel tank cover **(1)** and secure hook and loop tape **(2)**.

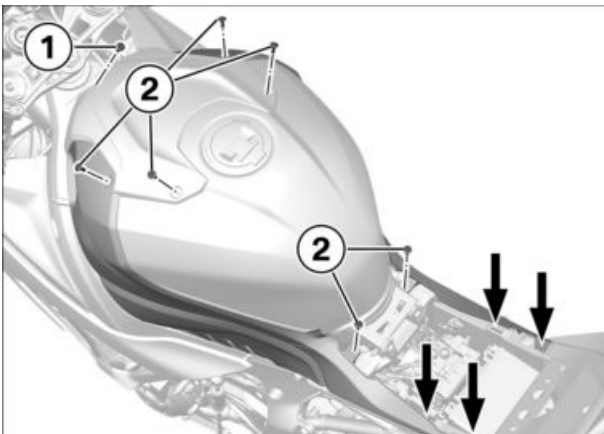

- Install screws (shorter collar) **(2)**.
- Install bolt **(1)** (long collar)
- Engage locators (**arrows**).

# 110

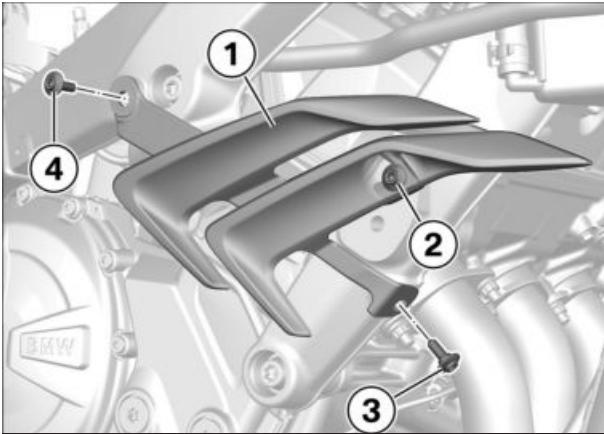

## ► Installing trim for right frame

- Slide trim **(1)** onto bolt **(2)** from the front.
- First, install screw **(3)**, then screw **(4)**.



# 111

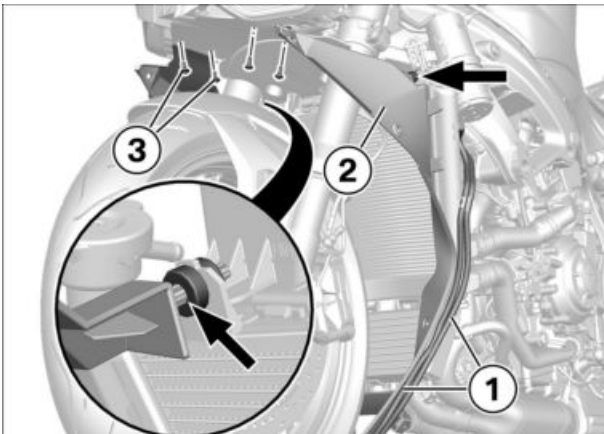

## ► Installing air deflector for radiator

- Fit air duct **(2)** and secure on left and right in rubber grommets **(arrow)**.
- Install screws **(3)**.
- Secure hoses **(1)** for tank ventilation in air duct **(2)**.



# 112

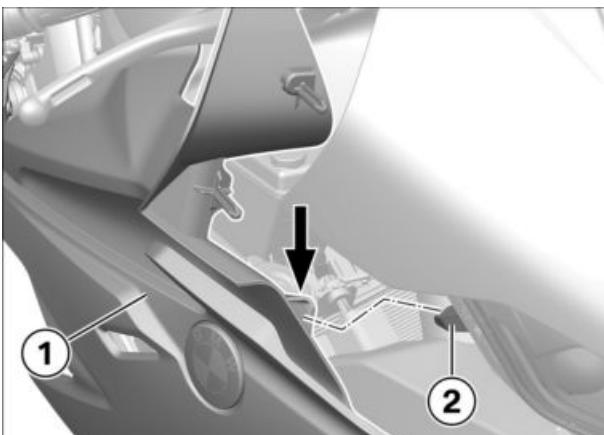

## ► Install fairing side panel with engine spoiler right and left

- When installing right fairing side panel **(1)**, make sure that lug **(2)** engages in holder **(arrow)**.

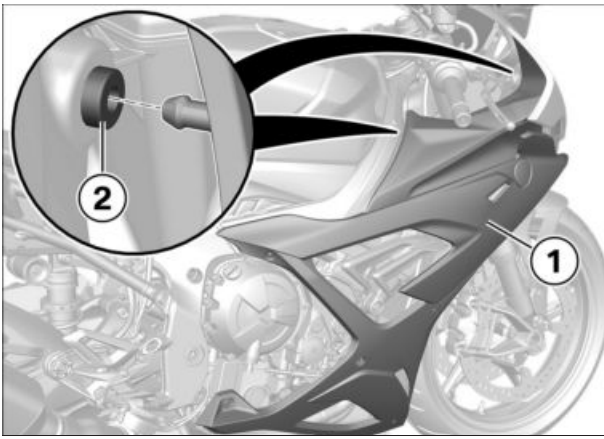

- Fit right fairing side panel **(1)** and secure in grommets **(2)**.

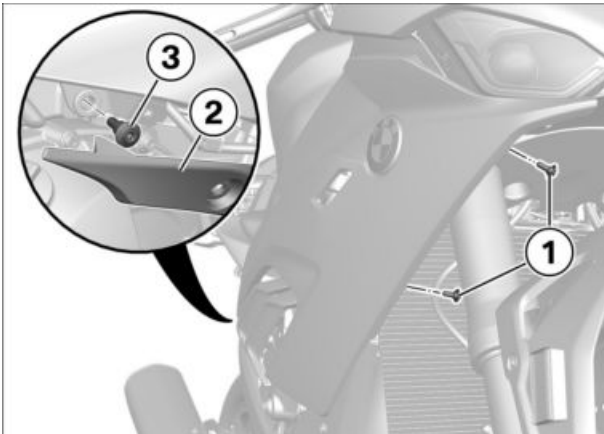

- Bend engine spoiler **(2)** down slightly and install bolt (9 mm collar) **(3)**.
- Position engine spoiler **(2)**.
- Install bolts (3 mm collar) **(1)**.

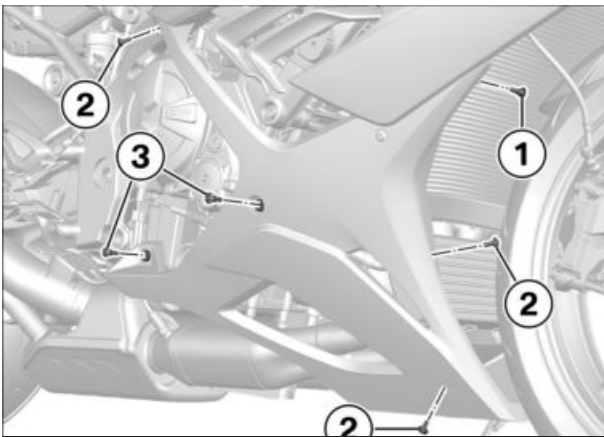

- Install bolts (9 mm collar) **(3)**.
- Install bolts (3 mm collar) **(2)**.
- Install bolt (6 mm collar) **(1)**.

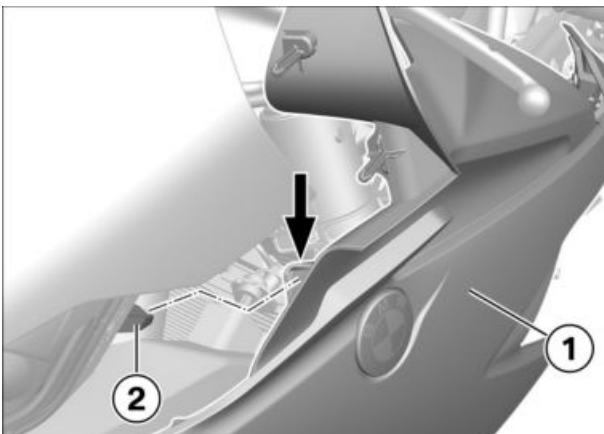

- When installing left fairing side panel **(1)**, make sure that lug **(2)** engages in holder **(arrow)**.

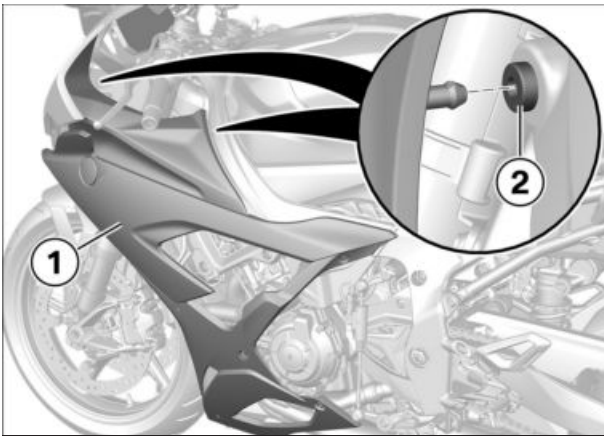

- Fit left fairing side panel **(1)** and secure in grommets **(2)**.

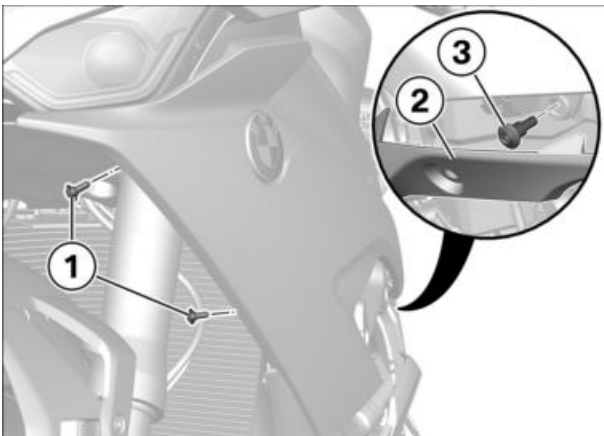

- Bend engine spoiler **(2)** down slightly and install bolt (9 mm collar) **(3)**.
- Position engine spoiler **(2)**.
- Install bolts (3 mm collar) **(1)**.

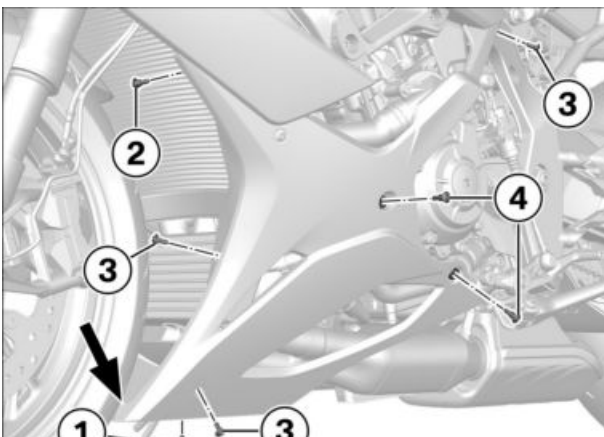

- Clip in locators (**arrow**).
- Install bolts (9 mm collar) **(4)**.
- Install bolts (3 mm collar) **(3)**.
- Install bolt (6 mm collar) **(2)**.
- Install screw (without collar) **(1)**.

# 113

## ► Connecting BMW Motorrad diagnostic system to vehicle

- Connect the BMW Motorrad battery charger.

### NOTICE

When carrying out diagnosis and programming, use a battery charger with 30 A approved by BMW Motorrad that ensures an **on-board system voltage of 13 V**.

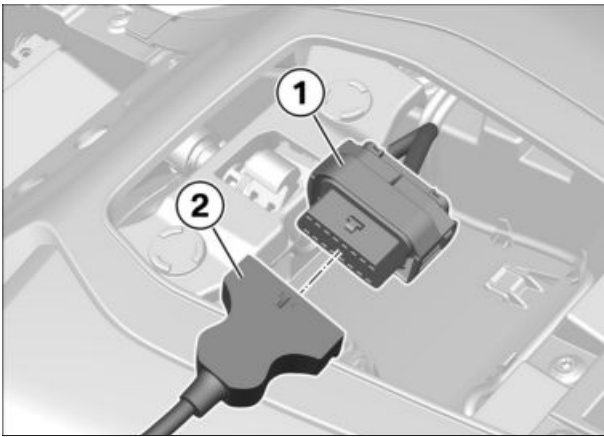

- Release diagnostic connector **(1)**.
- Connect connecting cable **(2)** of the BMW Motorrad diagnosis system to the diagnostic connector **(1)**.

#### **NOTICE**

See the information about the BMW Motorrad diagnostic system for all further instructions.

---

Additional work: 61 35 502 Setting limit for running-in rpm

---

## 114

- ▶ **Perform the vehicle test with BMW Motorrad diagnostic system, read out fault memory and reset adaptation values**

#### **NOTICE**

When working with the BMW Motorrad diagnostic system, always follow the instructions it issues.

- Perform the vehicle test and read out the fault memory.
- Perform all requisite repair work.
- Reset the adaptation values.
  - » This is the only way of ensuring correct operation of the vehicle.

## 115

- ▶ **Restoring date with BMW Motorrad diagnostic system**

- Select **Activities** from the menu and call up the **Service schedules**.
- Go to the **Read and set service date** menu option to calibrate the calendar date in the vehicle with the calendar date of the BMW Motorrad diagnostic system.

# 116

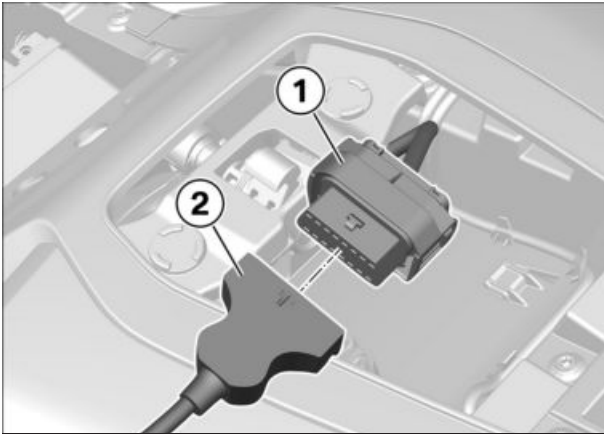

## ► Disconnecting BMW Motorrad diagnostic system from vehicle

- Close all diagnostic programs and switch off the ignition.
- Disconnect connecting cable (2) of the BMW Motorrad diagnosis system from diagnostic connector (1).
- Secure diagnostic connector (1).
- Disconnect the BMW Motorrad battery charger from the vehicle.



# 117

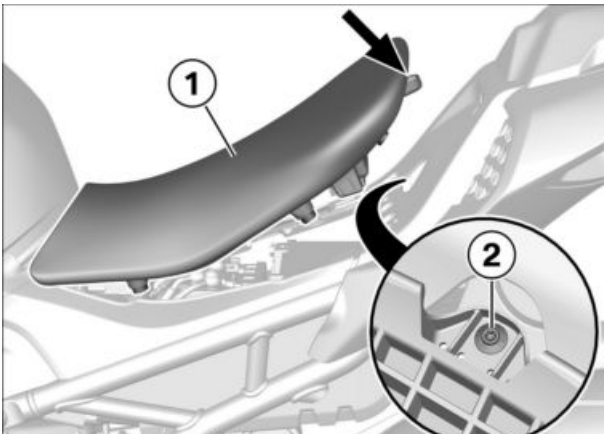

## ► Installing rider's seat

- Insert driver's seat (1) at front and position.
- Press driver's seat (1) to the front at the seat cushion surface (arrow).
- Position bolt (2) and install.



# 118

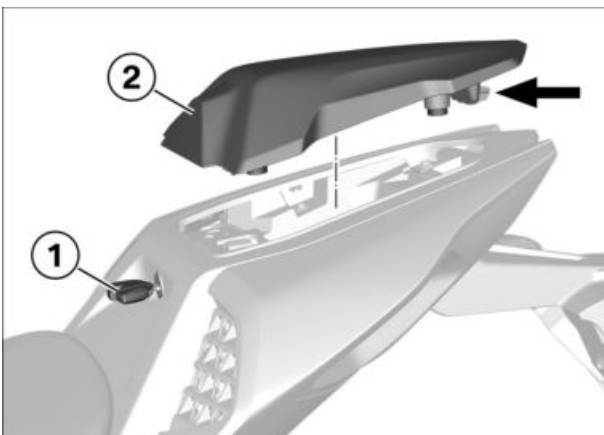

## ► Installing tail-hump cover

- Position tail-hump cover (2) while hooking fixture (arrow).
- Press tail-hump cover (2) down and lock with ignition key (1).



# 119

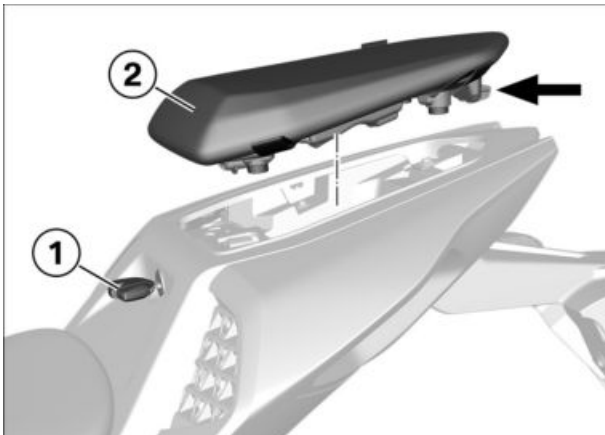

– with two-up riding package<sup>OE</sup> (0413)

## ► Installing passenger seat

- Position passenger seat **(2)** and hook in fixture **(arrow)**.
- Press passenger seat **(2)** downwards and lock using ignition key **(1)**.◊

# 120

## ► Final check of work performed

- Check the following:
  - The work as performed achieved the intended purpose.
  - All reservoirs and containers have been filled and all fluids and lubricants are at their correct levels.
  - All threaded fasteners released beforehand have been correctly retightened.
  - The fuel system is free of leaks.
  - The lights and signalling equipment are fully operational and the vehicle is roadworthy.
  - The brake pads of the front and rear brakes are bedded against the brake discs.

## ▷ Function test, engine start suppression

### Check

- Set kill switch to "ON" position.
- Select neutral.
  - » Neutral indicator light "N" lights up.
- Switch on the ignition.
  - » Neutral indicator light "N" goes out.
- Select a gear.
  - » Neutral indicator light "N" goes out.
- Press the starter button.
  - » Starter does **not** operate.
- Extend the side stand.
  - » Starter does **not** operate.
- Pull the clutch lever.
  - » Starter does **not** operate.
- Press the starter button.
  - » Starter does **not** operate.
- Retract the side stand.
  - » Starter does **not** operate.
- Press the starter button without releasing the clutch lever.
  - » Starter operates.

**Result**

Not all test steps completed successfully.

**Measure**

- Check the appropriate parts with the BMW Motorrad diagnostic system.



# Service Information Bulletin

Engine

March 15, 2021

11 02 21

## SERVICE ACTION: REPLACE CYLINDER HEAD



**BMW  
MOTORRAD**

### MODEL

E-Series	Model Description	Production Date
K67	S 1000 RR	To May 17, 2020

The affected vehicles have been marked with campaign number 0011460000 in AIR.

In order to determine if a specific vehicle is affected by this campaign it will be necessary to verify the vehicle VIN in AIR (Aftersales Information Research). Based on the response of the system, either proceed with the repair or take no further action. Please note, open campaigns or vehicle stops may not appear in DCS Warranty Vehicle Inquiry or sales systems until 24-72 hours after they are announced, therefore AIR is always the recommended method for determining open campaigns and vehicle stops.

### SITUATION

In the production of the titanium valves, a process deviation occurred in the surface coating of a production lot. The changed surface can result in increased wear of the valve guides over the service life.

For vehicles that have already been delivered, customers will be notified by BMW via first class mail. The letter will describe the situation and ask them to schedule an appointment as soon as possible to have the Technical Campaign carried out.

For vehicles that have not been delivered, the service campaign must be carried out **before delivery** to customers.

### CORRECTION

Engines produced since May 18, 2020 do not exhibit this condition and are not included in this campaign.

### PROCEDURE

Replace Cylinder Head. See repair instruction "00 60 383 Replace cylinder head"

NOTICE: Cylinder heads ship from the factory with certain bolts that will need to be tightened by the technician.

Screws for rocker arm axle are tightened with only 1 Nm from factory and need to be retightened to the specification shown below. A new sealing ring is not necessary.

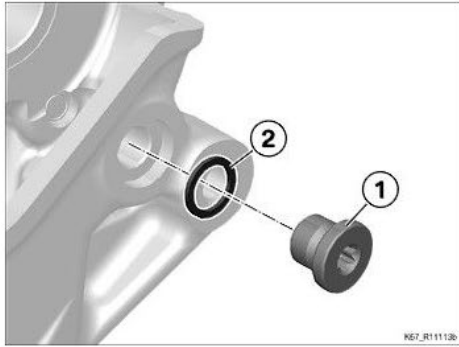

- Renew sealing ring (2) .
- Install screw plug (1) with sealing ring (2) .

Tightening torques		
Threaded plug (cam-follower shaft) to cylinder head		
M10 x 1	10 Nm	

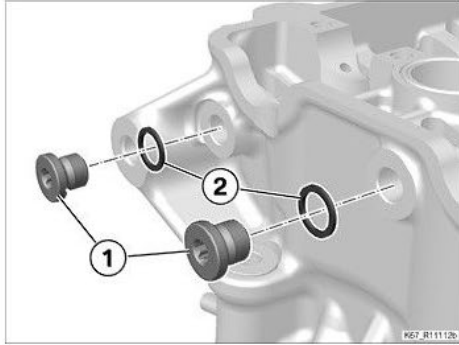

- Renew sealing rings (2) .
- Install screw plugs (1) with sealing rings (2) .

Tightening torques		
Threaded plug (cam-follower shaft) to cylinder head		
M10 x 1	10 Nm	

## PARTS INFORMATION

### Part Number

11 12 7 105 934	Cylinder head with valves
06 32 7 657 949	2× Bolt to MK oil cooler
06 32 7 727 783	Bolt M6×16 MK - Oil cooler return line to engine
07 11 9 909 546	O-ring (37.82×1.78) for housing cover screw plug, right
07 11 9 963 252	3× Sealing ring chain tensioner guides, oil drain plug
07 11 9 963 340	Sealing ring A20x24-AL
07 12 9 909 586	Cheese head screw MK to manifold
07 14 6 778 500	2× Nut M6
11 12 7 726 964	Set, O-ring for shaft coil
11 12 9 480 983	Gasket set for cylinder head cover and secondary air system
11 12 9 899 963	10× Cylinder head bolts
11 14 8 358 847	2× O-ring for switching cam actuator
13 53 9 480 898	O-ring for fuel pressure line
13 62 8 658 854	3× O-ring (switching cam sensor, camshaft sensor, crankshaft sensor)
13 64 7 675 557	3× O-ring for fuel injectors
17 22 7 680 668	2× O-ring for oil cooler to crankcase
18 51 8 542 088	4× Gasket, exhaust manifold
23 00 8 569 916	Locking washer (tab) pinion
23 00 8 569 927	Nut pinion 24×1.5

### Part number as needed

11 11 7 717 367	2× Fitting sleeve
11 12 8 569 342	Cylinder head gasket (1.02 mm 1-hole)
11 12 8 569 343	Cylinder head gasket (1.12 mm 2-hole)

## WARRANTY INFORMATION

Covered under the terms of the BMW New Vehicle Limited Warranty for Motorcycles, if applicable.

### **Defect code**

00 11 46 00 00	Replace cylinder head
----------------	-----------------------

### **Labor Operation**

00 60 383	Replace cylinder head	77 FRU
+00 60 883	Replace cylinder head	76 FRU
00 60 993	Bonus time for Technical Campaign	18 FRU

FRUs includes all repair procedures to complete the task with allowance for necessary ancillary tasks (e.g., visual inspection, lubrication, cleaning parts etc.) and administrative tasks.

Labor operation code 00 60 383 is a Main labor operation. If you are using a Main labor code for another repair, use the Plus code labor operation instead.

NOTICE: Affected vehicles can be retrieved from the customers to perform the campaign. A flat rate of 7 FRU with FRU number 00 98 510 can be invoiced for each vehicle for pickup and return.

NOTICE: Required oil/coolant can be entered on the warranty claim under a Sublet 04. BMW Motorrad recommends BMW Motorrad ADVANTEC Ultimate oil.

## QUESTIONS REGARDING THIS BULLETIN

Technical inquiries	Contact the BMW Technical Support Group via TSARA
Warranty inquiries	Submit an IDS ticket to the Warranty Department
Parts inquiries	Submit an IDS ticket to the Motorrad Parts Department

## Additional Information for SI B11 02 21: Replace Cylinder Head

Screws for rocker arm axle are tightened with only 1 Nm from factory and need to be retightened during assembly! A new sealing ring IS NOT necessary!

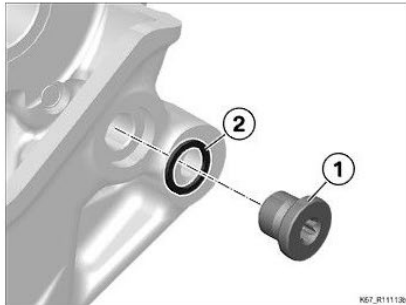

- Renew sealing ring (2) .
- Install screw plug (1) with sealing ring (2) .

Tightening torques		
Threaded plug (cam-follower shaft) to cylinder head		
M10 x 1	10 Nm	

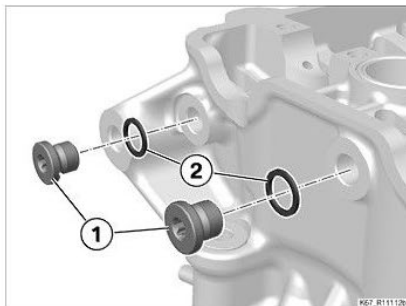

- Renew sealing rings (2) .
- Install screw plugs (1) with sealing rings (2) .

Tightening torques		
Threaded plug (cam-follower shaft) to cylinder head		
M10 x 1	10 Nm	

Parts delivery



7



Änderungseck ankleben