



## SIB 52 03 20

2021-03-01

## RATTLING NOISE FROM THE FRONT HEADREST

This Service Information Bulletin (Revision #1) replaces SI B52 03 20 **dated April 2020**.

**What's New** (Specific text highlighted):

- Production range expanded
- Warranty/Question sections updated

## MODEL

E-Series	Model Description	Production Date	Affected Option Code
G12	7 Series Sedan	All	04F4 Executive Lounge Seating

## SITUATION

A rattling noise can be heard coming from the front seat headrest.

This noise is only heard from headrests on vehicles equipped with the optional Executive Lounge Seating, SA (Option Code) 04F4.

## CAUSE

Excessive movement between the headrest's internal rod and sleeve.

## CORRECTION

Install anti-friction film tape on the headrest rod.

## PROCEDURE

1. Confirm the described noise in the Situation section.
2. If the noise can be reproduced, then remove the headrest from the front captain's chair as per the preliminary work in REP 67 31 570



3. Wrap film tape (arrows) around both headrest guideposts.

The wrapping should be 2-3 cm (approx.  $\frac{3}{4}$ " to 1  $\frac{1}{4}$ " wide).

4. Install the headrest onto the seat.
5. If the complaint also applies to the other front seat, then repeat the procedure on the other seat.
6. Perform a test drive to verify the noise is no longer heard.

## PARTS INFORMATION

Part Number	Description	Quantity
83 19 9 407 798	Film Tape (W=15 mm, L=33 m)	Sublet as needed

## WARRANTY INFORMATION

Covered under the terms of the BMW New Vehicle Limited Warranty for Passenger Cars and Light Trucks.

<b>Defect Code:</b>	<b>5210173900</b>	<b>Head restraint, front seat disruptive noises</b>
---------------------	-------------------	---

### Repairing one side-

Labor Operation	Description	Labor Allowance
51 14 394	Replace (remove and install) crash-active head restraint (Captain's Chair) <b>(Main work – one side) and repair</b>	Refer to AIR
Or:		
51 14 894	Replace (remove and install) crash-active head restraint (Captain's Chair) <b>(Plus work – one side) and repair</b>	Refer to AIR

Or:

### Repairing both sides-

Labor Operation	Description	Labor Allowance
51 14 394	Replace (remove and install) crash-active head restraint (Captain's Chair) <b>(Main work – one side) and repair</b>	Refer to AIR
Or:		
51 14 894	Replace (remove and install) crash-active head restraint (Captain's Chair) <b>(Plus work – one side) and repair</b>	Refer to AIR
And:		
52 99 000	Work time to remove and install the crash-active head restraint (Captain's Chair) on the <b>other side and repair</b>	18 FRU

If you are using a Main labor code for another repair, use the Plus code labor operation 51 14 894 instead of 51 14 394.

Refer to AIR for the corresponding flat rate unit (FRU) allowances.

Work time labor operation code 52 99 000 is not considered a Main labor operation.

As applicable to your center, please refer to **SI B01 01 20** or **B01 07 20** for claiming your diagnosis work time, job/repair work time (WT), RO/Claim WT and/or repair explanation procedures, unless otherwise required by State law.

And, as needed:

### Sublet – Bulk Materials (RO and Claim Comments Required)

<b>Sublet Code 4</b>	See the sublet reimbursement calculations below	Reimbursement for the repair-related bulk material (Do not use the BMW part number for claim submission)
----------------------	---	--

Sublet reimbursement calculation for claiming the applicable repair-related bulk material (BMW part number) is at the dealer net price amount for the quantity used plus your center's handling.

Enter this material cost in sublet and itemize the amount on the repair order and in claim comment section.

### **QUESTIONS REGARDING THIS BULLETIN**

Technical inquiries	Submit feedback at the top of this bulletin
Warranty inquiries	Please contact the Warranty department by either using the Live Chat that's available in the Warranty Documentation Portal or through IDS by selecting Coverage, Policy, Coding Questions and Mileage Corrections
Parts inquiries	Submit an IDS ticket to the Parts Department

#### Supporting Materials

[picture\\_as\\_pdf B52 03 20 REP 67 31 570.pdf](#)

BMW Group - AIR: 2020-03-31 / 11:47

Dealer: -/-

Model: 750Li

Development code: G12

Model code: 7F03

Lead type: 7F03

Removing and installing/replacing the drive for the headrest height adjustment at the front seat on the left or right (left or right) (after vehicle diagnosis) »



## NOTE

Description is for left component only. Procedure on the right side is identical.

## Preliminary work

### Remove the rear panel of the front seat backrest



- Loosen the expanding rivet (1).



- Loosen the rear panel in the following sequence.
  - Pull the left-hand rear panel towards the outside.
  - Detach the rear panel detents on the left towards the rear.
  - Pull the right-hand rear panel towards the outside.
  - Detach the rear panel detents on the right towards the rear.

- Pull out the rear panel (1) in this area (2) from the

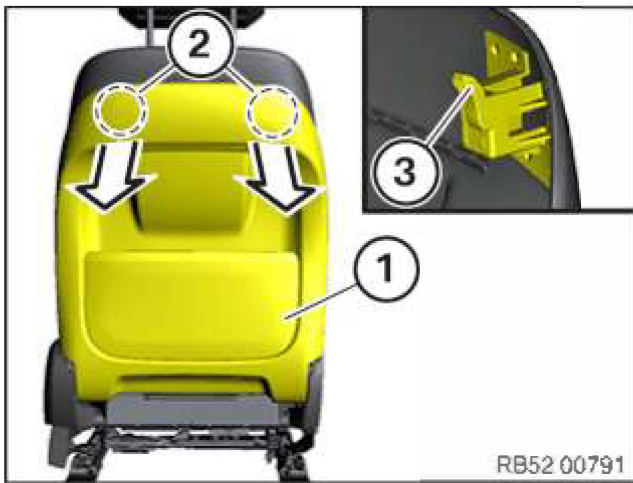

guides (3) towards the bottom.

- If necessary, unlock associated plug connection and disconnect.

## Install head restraint on front seat

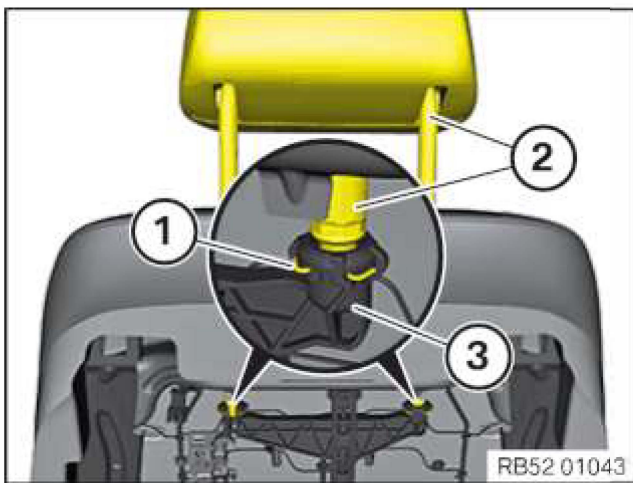

- Slightly spread the clamps (1) and pull the head restraint (2) from the drive (3).

Replace the drive for the headrest height adjustment (3) as soon as the head restraint is removed.

- Remove the head restraint (2) upwards out of the backrest.

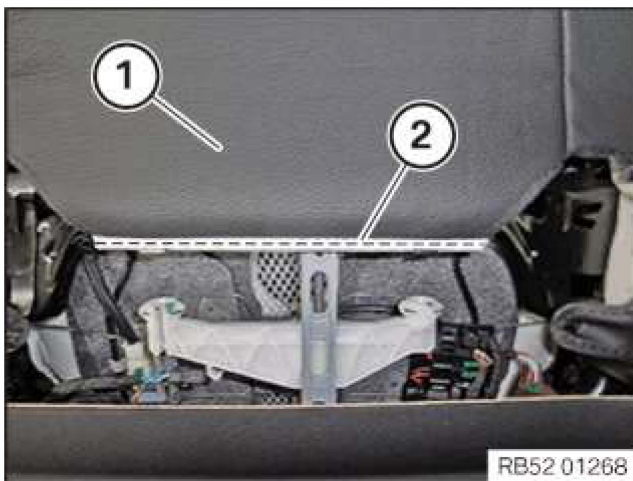

- Detach the cover of the backrest (1) in the area (2) and fold up.

- Disconnect plug connection (1).
- Unlock the retaining lug (2) and shift the drive (3) in the direction of the arrow.
- Feed out the drive for the headrest height adjustment (3) downwards.

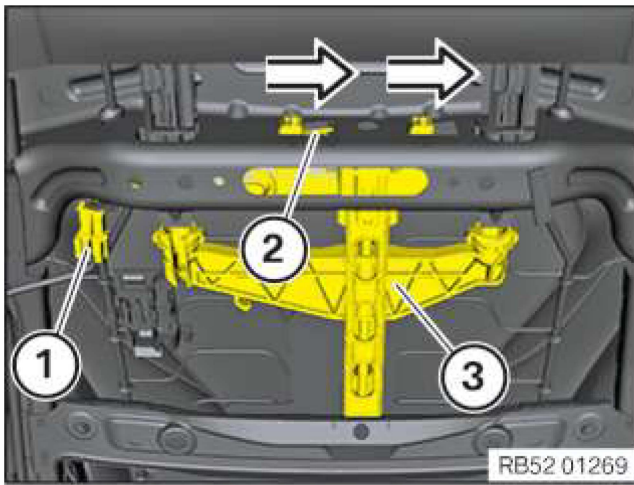

## Main Works

### Removing the drive for the headrest height adjustment on the front seat

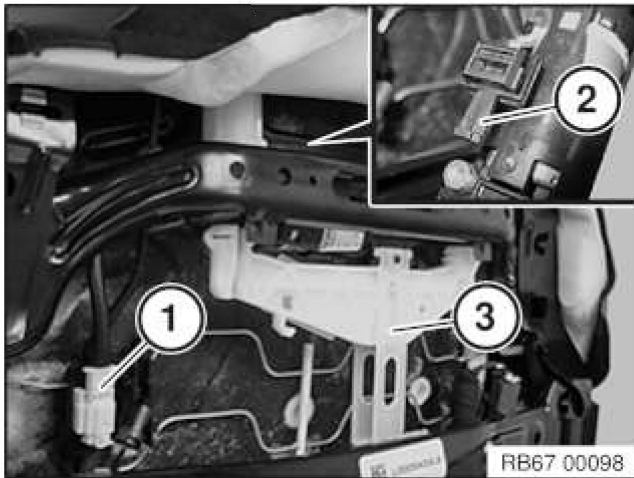

- Unlock and disconnect connector (1).
- Unlock the detent (2).
- Slide the drive for the headrest height adjustment (3) to the right and remove.

### Installing the drive unit for the headrest height adjustment on the front seat

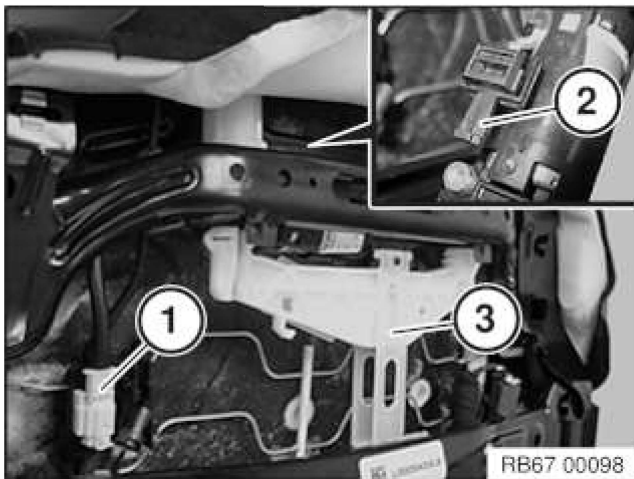

- Correctly position the drive unit for the headrest height adjustment (3) and push it to the left until the detent (2) engages.
- Connect plug (1).

## Follow-up works

### Install head restraint on front seat

- Renew the drive for the headrest height adjustment

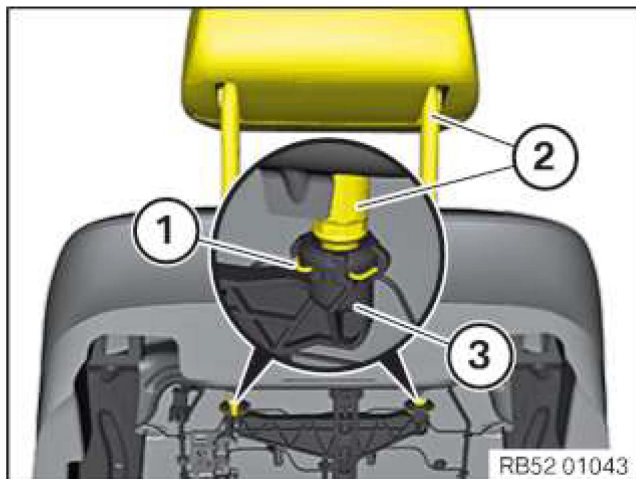
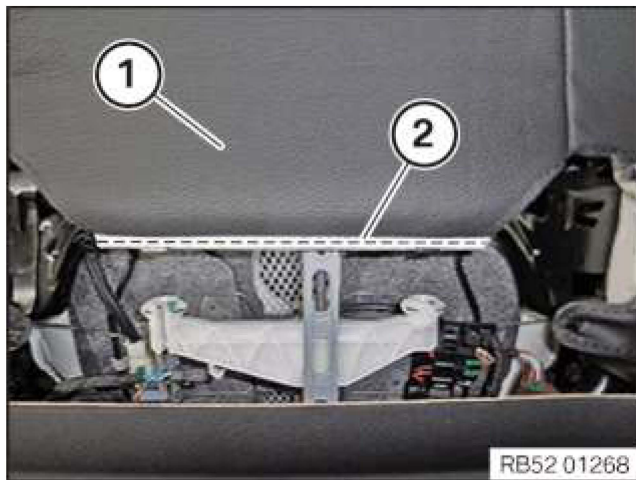
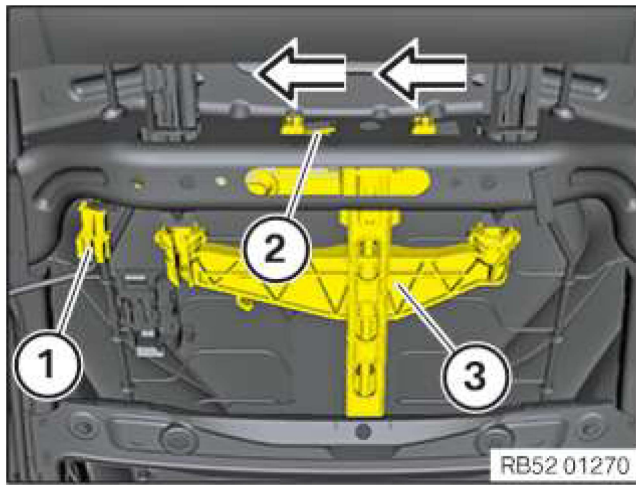

(3).

Parts: Drive for the headrest height adjustment.

- Feed the drive (3) into the backrest and position.
  - Shift drive (3) in arrow direction until retaining lug (2) is securely locked.
  - Connect connector (1).
- 
- Position cover of backrest (1) in area (2) and attach.

- Insert head restraint (2) from the top in the backrest.

- Insert head restraint (2) into the drive (3).

The clamps (1) must engage.

- Check the correct fit of the head restraint (2) in clamps (1).

## Mount the rear panel on the front seat backrest

- Check the retaining lugs (1) and guides (2) of the rear panel (3) for damage.

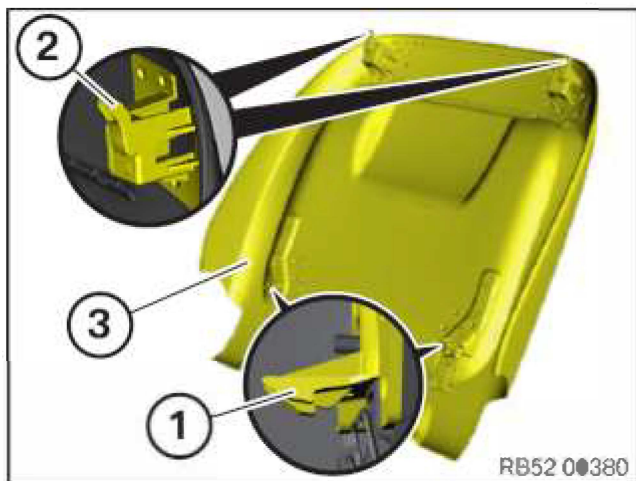

- If required, connect the associated connector.
- Insert the rear panel (1) towards the top in this area (2), including the guides (3).

- Install the rear panel in the following sequence.
  1. Pull the right-hand rear panel towards the outside.
  2. Press the right rear panel towards the front and hold it.
  3. Pull the left-hand rear panel towards the outside.
  4. Press the left rear panel towards the front and center the rear panel.

- Attach the expanding rivets (1).





## Initializing the electrical seat adjustment drives

### **i** TECHNICAL INFORMATION

During initialization, the end positions of the respective electrical drive for the seat adjustment are recorded and stored.

An initialization must be performed: after renewal of a drive for the seat adjustment and after renewal/programming of the control unit for the seat adjustment.

- Shift the corresponding seat adjustment drives to both end positions using the operating unit.