

# MIL ON DTC P125D71 - Fuel Flow Control Valve Stuck

**Service Category** Engine/Hybrid System

**Section** Fuel System

**Market** USA

Toyota Supports  
ASE Certification 

## Applicability

YEAR(S)	MODEL(S)	ADDITIONAL INFORMATION
2015 - 2017	NX200T	
2018 - 2020	NX300	

### REVISION NOTICE

March 12, 2021 Rev1:

- The Introduction, Warranty Information, and Parts Information sections have been updated. Any previous printed versions of this bulletin should be discarded.

## Introduction

Some 2015 – 2017 NX 200t and 2018 – 2020 NX 300 model year vehicles may exhibit a MIL ON condition with Diagnostic Trouble Code (DTC) P125D71 (Fuel Flow Control Valve Performance Actuator Stuck) present. The Multi-Information Display (MID) may tell the customer “reduced engine power – take vehicle to nearest dealer.” The Engine Control Module (ECM) (SAE term: Powertrain Control Module/PCM) logic has been modified to reduce the possibility of this condition. Follow the Repair Procedure in this bulletin to address this condition.

## Warranty Information

OP CODE	DESCRIPTION	TIME	OFF	T1	T2
EG1916	R & R of Fuel Suction Plate, Harness, Filter, and PDV Recalibrate Engine ECU	3.2	89661-78XXX*	8A	99

### APPLICABLE WARRANTY

- This repair is covered under the Lexus Federal Emission Warranty. This warranty is in effect for 96 months or 80,000 miles, whichever occurs first, from the vehicle’s in-service date.
- Warranty application is limited to occurrence of the specified condition described in this bulletin.

\*Choose the correct OFF for the vehicle being repaired by searching the parts in EPC using the EPC VIN filter. Warranty claims must be submitted with the correct OFF with 10 digits.

## MIL ON DTC P125D71 - Fuel Flow Control Valve Stuck

### Parts Information

PART NUMBER		PART NAME	QTY
PREVIOUS	NEW		
77024-78020	77024-78040	Plate Sub-assy, Fuel Suction	1
23990-36010		Valve Assy, Pressure Discharge	1
77785-78040		Harness, Fuel Pump	1
23217-36010		Filter, Suction	1
90301-04013		Ring, O	1
90301-15024			1
90301-08019	90301-A0021		1
90301-11025	90301-A0027		1
00451-00001-LBL			Authorized Modifications Labels
89661-78XXX		Computer, Engine Control (ECM/PCM)	–

**NOTE**

- The ECM (PCM) should NOT be replaced as part of the Repair Procedure.
- Authorized Modifications Labels may be ordered in packages of 25 from the Materials Distribution Center (MDC) through *Dealer Daily – Parts – Dealer Support Materials Orders*.

### Required Tools & Equipment

REQUIRED EQUIPMENT	SUPPLIER	PART NUMBER	QTY
Techstream ADVI*	ADE	TSADVUNIT	1
Techstream 2.0		TS2UNIT	
Techstream Lite		TSLITEPDLR01	
Techstream Lite (Green Cable)		TSLP2DLR01	

\*Essential SST.

**NOTE**

- Only ONE of the Techstream units listed above is required.
- Software version 15.30.027 or later is required.
- Additional Techstream units may be ordered by calling Approved Dealer Equipment (ADE) at 1-800-368-6787.
- Use Techstream or an approved J2534 interface to perform flash reprogramming updates. Visit [techinfo.toyota.com](http://techinfo.toyota.com) for more information regarding J2534 reprogramming.

## MIL ON DTC P125D71 - Fuel Flow Control Valve Stuck

---

### Required Tools & Equipment (continued)

SPECIAL SERVICE TOOLS (SST)	PART NUMBER	QTY
Battery Diagnostic Tool*	<a href="#">DCA-8000P T</a>	1

\*Essential SST.

**NOTE**

Additional SSTs may be ordered by calling 1-800-933-8335.

### Calibration Information

MODEL	YEAR	CALIBRATION ID	
		PREVIOUS	NEW
NX 200t	2015 – 2017	896637805900	<a href="#">896637870000</a>
		896637805800	
		896637805700	
		896637805600	
		896637805500	
		896637805400	
		896637805300	
		896637805200	
		896637806900	<a href="#">896637871000</a>
		896637806800	
		896637806700	
		896637806600	
		896637806500	
		896637806400	
		896637806300	
		896637806200	
		896637807900	<a href="#">8966378F3000</a>
		896637807800	
		896637807700	
		896637807600	
		896637807500	
		896637807400	
		896637807300	
		896637807200	

## MIL ON DTC P125D71 - Fuel Flow Control Valve Stuck

---

### Calibration Information (continued)

MODEL	YEAR	CALIBRATION ID	
		PREVIOUS	NEW
NX 300	2018	896637850100 896637850000	<a href="#">896637850200</a>
		896637851100 896637851000	<a href="#">896637851200</a>
		896637852100 896637852000	<a href="#">896637852200</a>
	2019	896637873200 896637873100 896637873000	<a href="#">896637873300</a>
		896637878200 896637878100 896637878000	<a href="#">896637878300</a>
		896637879200 896637879100 896637879000	<a href="#">896637879300</a>
	2020	8966378B2000	<a href="#">8966378B2100</a>
		8966378B3000	<a href="#">8966378B3100</a>
		8966378B4000	<a href="#">8966378B4100</a>

### Repair Procedure

- Using Techstream, check for DTC P125D71 (Fuel Flow Control Valve Performance Actuator Stuck).  
Is DTC P125D71 present?
  - YES** — Continue to step 2.
  - NO** — This bulletin does NOT apply. Continue diagnosis using the applicable Repair Manual.
  
- Perform Active Test using Techstream (*Powertrain – Engine – Active Test – Activate the Fuel Pressure Discharge*).  
Does the fuel pressure fluctuate by at least 4 psig?
  - YES** — This bulletin does NOT apply. Continue diagnosis using the applicable Repair Manual.
  - NO** — Continue to step 3.

## MIL ON DTC P125D71 - Fuel Flow Control Valve Stuck

### Repair Procedure (continued)

3. Use Techstream to confirm if the ECM (PCM) calibration has been updated and check for the Authorized Modifications Label affixed to the vehicle in the location shown below. Is the calibration ID listed in Techstream and on the label the latest ECM (PCM) calibration?
  - **YES** — This bulletin does NOT apply. Continue diagnosis using the applicable Repair Manual.
  - **NO** — Continue to step 4.

**Figure 1. Location of Authorized Modifications Label on 2015 – 2017 NX 200t and 2018 – 2020 NX 300**

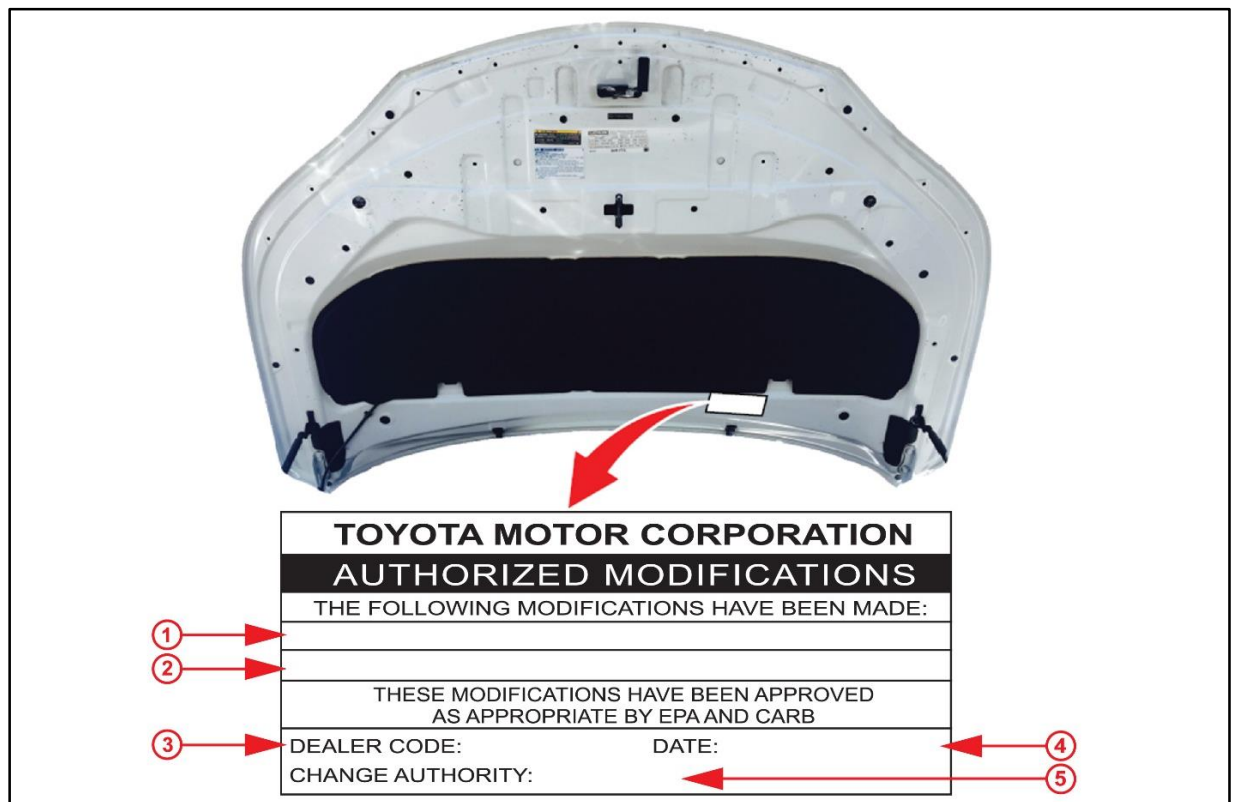

<b>1</b>	Replacement ECM (PCM) Part Number (e.g., 89661-78XXX)
<b>2</b>	New Calibration ID (e.g., 896637870000)
<b>3</b>	Dealer Code

<b>4</b>	Date Completed
<b>5</b>	This SB Number

## MIL ON DTC P125D71 - Fuel Flow Control Valve Stuck

---

### Repair Procedure (continued)

4. Flash reprogram the ECM (PCM).

**NOTE**

- The battery diagnostic tool **MUST** be used in Power Supply Mode to maintain battery voltage at 13.5V while flash reprogramming the vehicle.
- For details on how to use the battery diagnostic tool, refer to the [DCA-8000 Instruction Manual](#) located at *TIS – Diagnostics – Tools & Equipment – Battery Diagnostics*.

Follow the procedures outlined in Service Bulletin [L-SB-0001-18](#), *Techstream ECU Flash Reprogramming Procedure*, and flash the ECM (PCM) with the NEW calibration file update.

5. Prepare and install the Authorized Modifications Label.
  - A. Using a permanent marker, enter the following information on the label:
    - ECM (PCM) part number [Refer to the Parts Information section for the NEW PART NUMBER]
    - Calibration ID(s) [Refer to the Calibration Information section for the NEW CALIBRATION ID]
    - Dealer Code
    - Repair Date
    - Change Authority [This bulletin number]
  - B. Install the Authorized Modifications Label onto the vehicle at the location shown in Figure 1. The Authorized Modifications Label is available through the MDC, P/N 00451-00001-LBL.

6. Remove the fuel pump assembly.

Refer to TIS, applicable model and model year Repair Manual:

- [2015 – 2017](#) NX 200t:  
*Engine/Hybrid System – Fuel System – “8AR-FTS (Fuel): Fuel Pump: Removal”*
- [2018 – 2020](#) NX 300:  
*Engine/Hybrid System – Fuel System – “8AR-FTS (Fuel): Fuel Pump: Removal”*

7. Disassemble the fuel pump assembly.

Refer to TIS, applicable model and model year Repair Manual:

- [2015 – 2017](#) NX 200t:  
*Engine/Hybrid System – Fuel System – “8AR-FTS (Fuel): Fuel Pump: Disassembly”*
- [2018 – 2020](#) NX 300:  
*Engine/Hybrid System – Fuel System – “8AR-FTS (Fuel): Fuel Pump: Disassembly”*

## MIL ON DTC P125D71 - Fuel Flow Control Valve Stuck

### Repair Procedure (continued)

8. Remove the pressure discharge valve from the fuel suction plate sub-assembly.
  - A. Disconnect the connector from the pressure discharge valve assembly.
  - B. Detach the two claws and pressure discharge valve assembly from the fuel suction tube assembly with pump.

**Figure 2.**

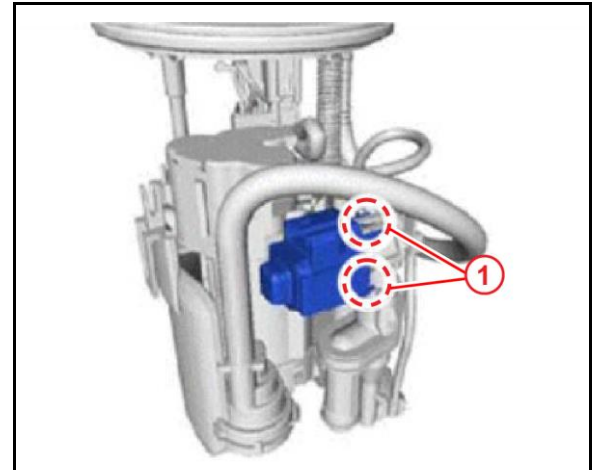

<b>1</b>	<b>Claw Location</b>
----------	----------------------

9. Install the NEW pressure discharge valve and attach the two claws and pressure discharge valve assembly to the fuel suction tube assembly with pump.
  
10. Reassemble the fuel pump with the NEW fuel suction tube assembly with pump and applicable O-rings.  
 Refer to TIS, applicable model and model year Repair Manual:
  - [2015 – 2017](#) NX 200t:  
*Engine/Hybrid System – Fuel System – “8AR-FTS (Fuel): Fuel Pump: Reassembly”*
  - [2018 – 2020](#) NX 300:  
*Engine/Hybrid System – Fuel System – “8AR-FTS (Fuel): Fuel Pump: Reassembly*
  
11. Install the fuel pump assembly into the fuel tank.  
 Refer to TIS, applicable model and model year Repair Manual:
  - [2015 – 2017](#) NX 200t:  
*Engine/Hybrid System – Fuel System – “8AR-FTS (Fuel): Fuel Pump: Installation”*
  - [2018 – 2020](#) NX 300:  
*Engine/Hybrid System – Fuel System – “8AR-FTS (Fuel): Fuel Pump: Installation”*

## MIL ON DTC P125D71 - Fuel Flow Control Valve Stuck

---

### Repair Procedure (continued)

12. Install the fuel tank assembly.

Refer to TIS, applicable model and model year Repair Manual:

- [2015 – 2017](#) NX 200t:  
*Engine/Hybrid System – Fuel System – “8AR-FTS (Fuel): Fuel Tank: Installation”*
- [2018 – 2020](#) NX 300:  
*Engine/Hybrid System – Fuel System – “8AR-FTS (Fuel): Fuel Tank: Installation”*

13. Complete the Confirmation Driving Pattern to confirm the DTC is no longer present.

Refer to TIS, applicable model and model year Repair Manual:

- [2015 – 2017](#) NX 200t:  
*Engine/Hybrid System – Engine Control – “8AR-FTS (Engine: Control): SFI System: P125D71”*
- [2018 – 2020](#) NX 300:  
*Engine/Hybrid System – Engine Control – “8AR-FTS (Engine: Control): SFI System: P125D71”*