



Spartan RV Chassis

Technical Service Bulletin
CSB21-340-001

<u>DATE:</u>	March 11, 2021
<u>APPLIES TO:</u>	This service bulletin applies to certain 2018 through 2022 model year K2, K3 and K4 model Spartan RV motor home chassis built between May 7, 2018 and December 3, 2020 that are equipped with RTS and RTSe rear suspensions supplied by Reyco Granning, LLC.
<u>CONDITION:</u>	RTS and RTSe rear suspension component identified below is under desired torque value.
<u>CORRECTION:</u>	See details below.
<u>LABOR ALLOCATION:</u>	Up to 1 hour
<u>CLASSIFICATION:</u>	V3
<u>TOOLS NEEDED:</u>	Calibrated torque tool capable of applying 770 lbs-ft +/- 25 lbs ft.

Please Read the Entire Bulletin and reference Reyco Granning manuals D713816 and D715154 before proceeding with any work. Follow industry standards regarding safety equipment and procedures. Refer any questions to Spartan RV Chassis Customer & Product Support Group (855) 589-9836.



WARNING: Use jack stands or other safety devices to properly support vehicle. Failure to safely support the vehicle and follow the procedures in this bulletin can lead to property damage and/or personal injury.

Ensure vehicle's air suspension is at the designed ride height prior to starting work. Ride height can be measured vertically from the bottom of the frame rail to the center of the wheel spindle and must be 8.25 inches.

Service Bulletins are intended for use by Professional Technicians only. They are written to guide Professional Technicians in performing service to vehicles of specific nature in conjunction with industry standards. Professional Technicians should be appropriately trained on industry standards and have the tools and equipment to perform procedures safely and properly.

Step by Step Instructions:

1. Referring to Figure 1, from the nut side of the eight (8) fasteners, torque the fastener to 700 lbs ft, +/- 25 lbs ft.
2. If the nut side of the fastener is not accessible, torque the bolt side of the eight (8) fasteners to 770 lbs ft, +/- 25 lbs ft.

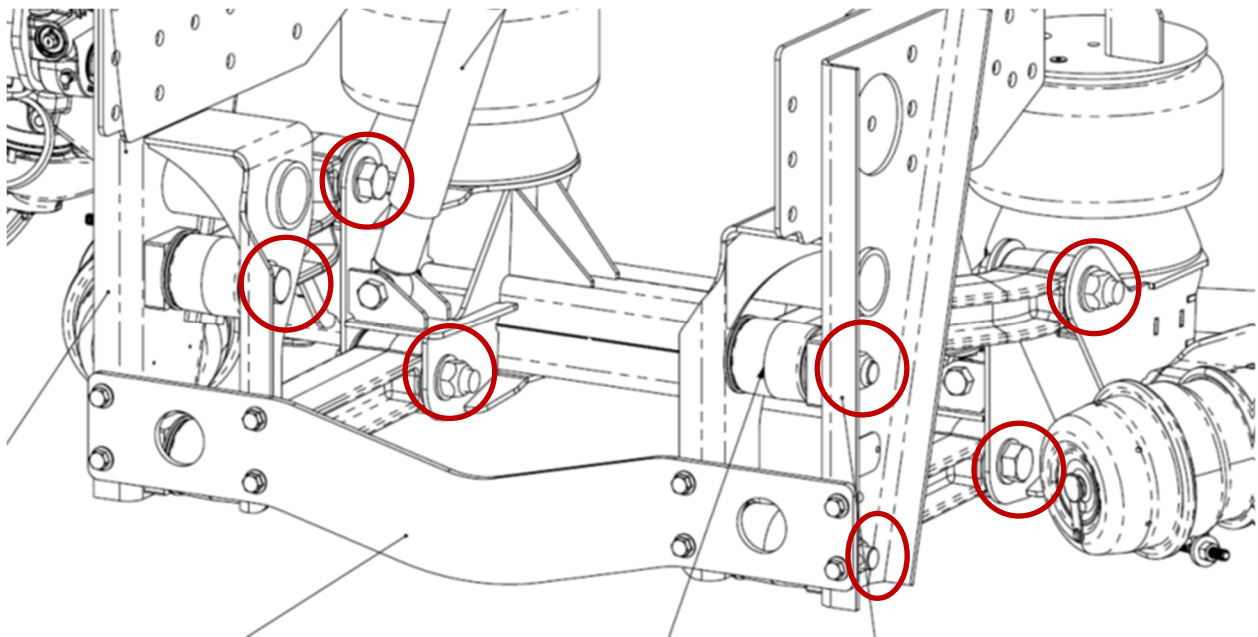

Figure 1

Note: There are a total of eight (8) fasteners to be torqued. Only seven (7) are visible in Figure-1.

Service Bulletins are intended for use by Professional Technicians only. They are written to guide Professional Technicians in performing service to vehicles of specific nature in conjunction with industry standards. Professional Technicians should be appropriately trained on industry standards and have the tools and equipment to perform procedures safely and properly.



Spartan RV Chassis

Technical Service Bulletin CSB21-340-001

For campaign coverage, the following must be supplied with the warranty claim and submitted to Spartan RV Chassis. Not submitting this information may delay payment of the invoice.

1. Suspension serial number (located on tag at front of suspension on driver's side hanger)
2. Repair Date
3. Vehicle mileage

Service Bulletins are intended for use by Professional Technicians only. They are written to guide Professional Technicians in performing service to vehicles of specific nature in conjunction with industry standards. Professional Technicians should be appropriately trained on industry standards and have the tools and equipment to perform procedures safely and properly.