

FSB 258-041, Diesel exhaust fluid (DEF) crystallization, dosing valve, clean (DTC P20EE SCR NOx Catalyst Efficiency Below Threshold (Bank 1))
CHU, CXU, GU, AN, GR

FSB 258-041 Diesel Exhaust Fluid (DEF) crystallization, Dosing valve, Clean

DTC P20EE SCR NOx Catalyst Efficiency Below Threshold (Bank 1)

(March 2021)

MACK Trucks built between January, 2019 and December, 2020, experiencing DTC P20EE –SCR NOx Catalyst Efficiency Below Threshold (Bank 1) and having a large amount of Crystals present in the 1-Box SCR should follow the outlined repair to clean out the crystal build up, remove the dosing valve gasket, and run a Sulfur regeneration.

Required Parts

Quantity	Part Number	Part Description
1	23108406	Clamp and Gasket Kit
3	990413	Dosing Valve Screws
1	21376801	Dosing Valve Sealing Plate

Confirm the truck was built between the above date range and has a large amount of Crystal buildup.

An example of expected crystal buildup can be seen below:



T2167961

Note: This FSB only applies to 1-Box EATS Systems. 2-Box systems are not covered in this bulletin.

Repair Procedure

NOTE: Information is subject to change without notice. Illustrations are used for reference only and can differ slightly from the actual vehicle being serviced. However, key components addressed in this information are represented as accurately as possible.

With the truck confirmed to be within the build date range and a large amount of crystal build up is present follow the below steps:

- 1 Apply the parking brake.
- 2 Place the transmission in neutral or park.
- 3 Install the wheel chocks.

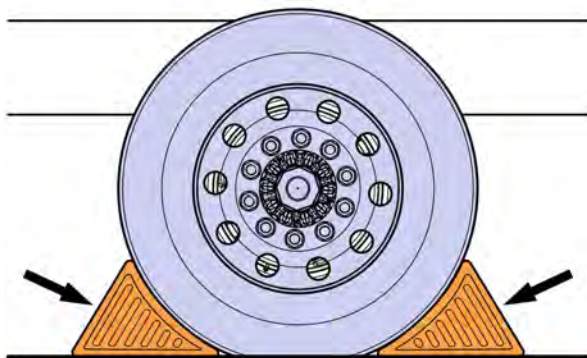

W7086748

- 4 Unlatch and remove the battery box cover.
- 5 Disconnect the cable from the battery's negative terminal.

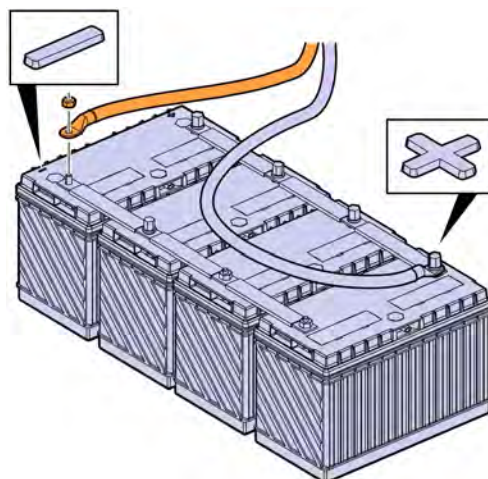

T3164283

- 6 Unlatch and raise the hood
- 7 Remove the chassis side fairings or step rail assembly
- 8 Remove the lower right splash shield.
- 9 Remove the chassis side fairing or step rail bracket assemblies.
- 10 Remove the heat shields.

 WARNING	
<p>Risk of chemical burn. Reagent (Diesel Exhaust Fluid) can cause personal injury and damage to equipment.</p> <ul style="list-style-type: none">▶ Use the appropriate protective equipment.▶ Reagent (Diesel Exhaust Fluid) that is spilled on hot parts can vaporise quickly. Turn away your face!▶ If reagent (Diesel Exhaust Fluid) comes into contact with skin or eyes, rinse thoroughly with water.▶ If reagent (Diesel Exhaust Fluid) is inhaled, breathe in fresh air.▶ When work is finished, clean the equipment and tools that have come into contact with reagent (Diesel Exhaust Fluid). Discard used gloves in the container for recycling.	

- 11 Disconnect the connector.

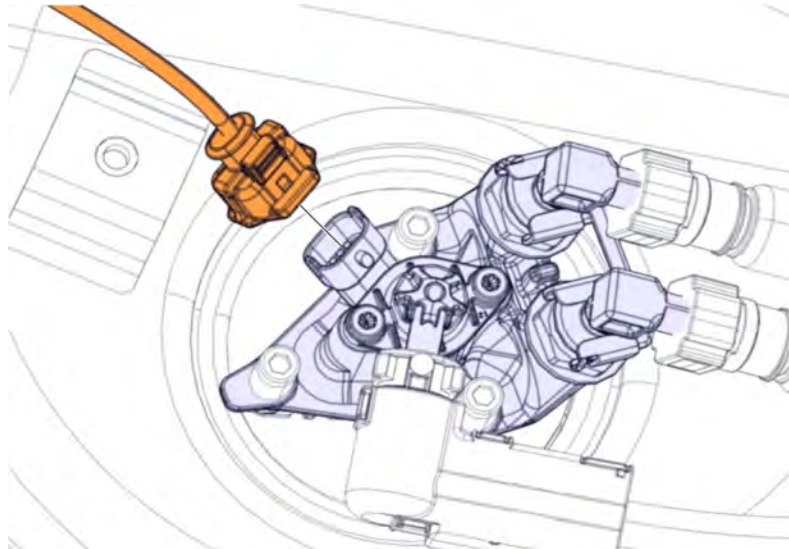

T2167946

12 Remove the screws.

13 Remove the dosage valve.

Note: Discard the screws.

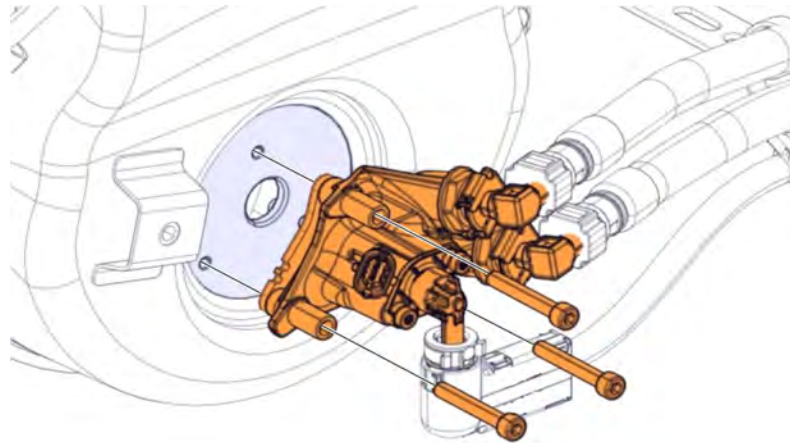

T2167947

14 Remove the gasket.

Note: Discard the gasket.

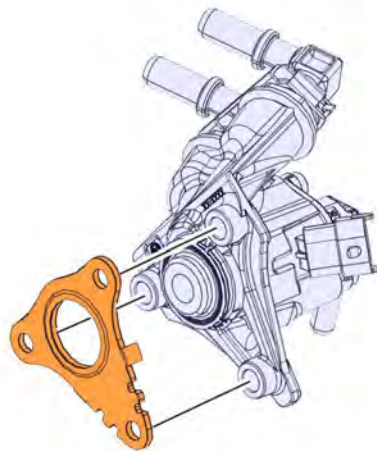

T2167959

15 Remove the sealing plate.

Note: Discard the sealing plate.

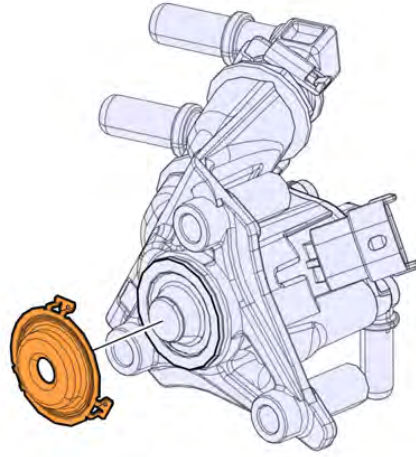

T2167948

16 Remove the screws.

Note: Discard the screws.

17 Remove the bracket.

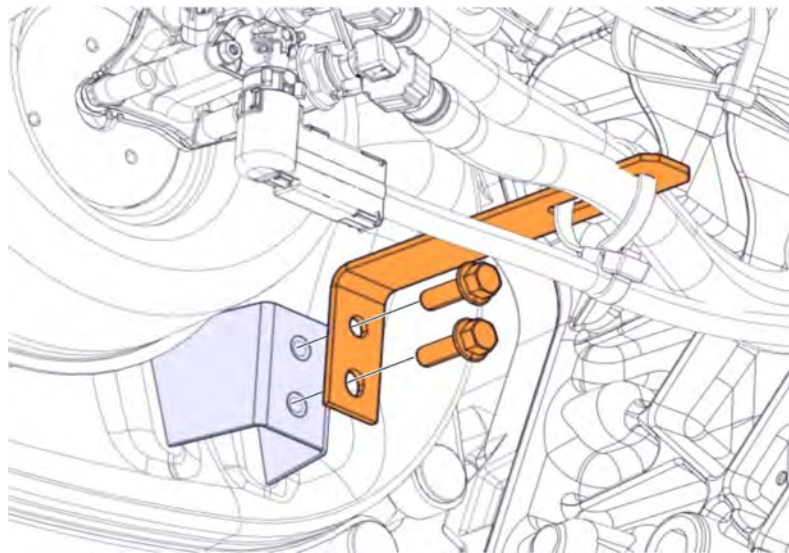

T2167949

18 Use a plastic bag to cover the dosage valve.

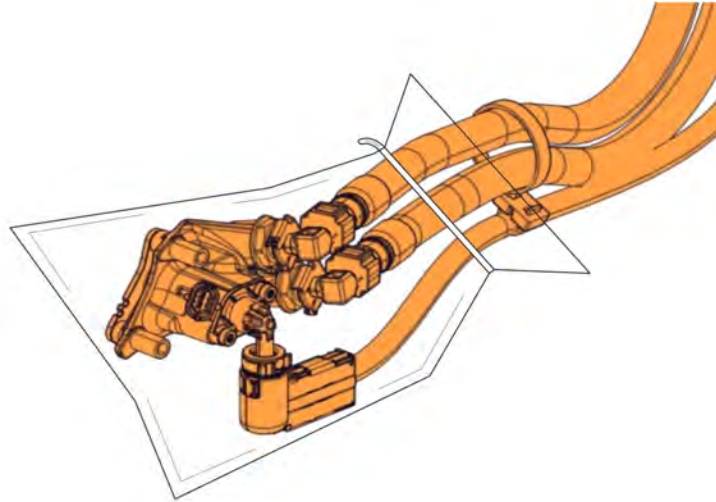

T2167950



WARNING

Risk of burn injuries. Heated components and mechanical parts can cause burns.
► Exercise caution when working with heated components. Always use the appropriate protective equipment.



DANGER

Risk of serious injury. Risk of inhaling noxious soot and toxic gases. Particulate matter can be absorbed through the skin. ► Always wear a protective filter mask, eye protection and nitrile gloves.

19 Remove the tube.

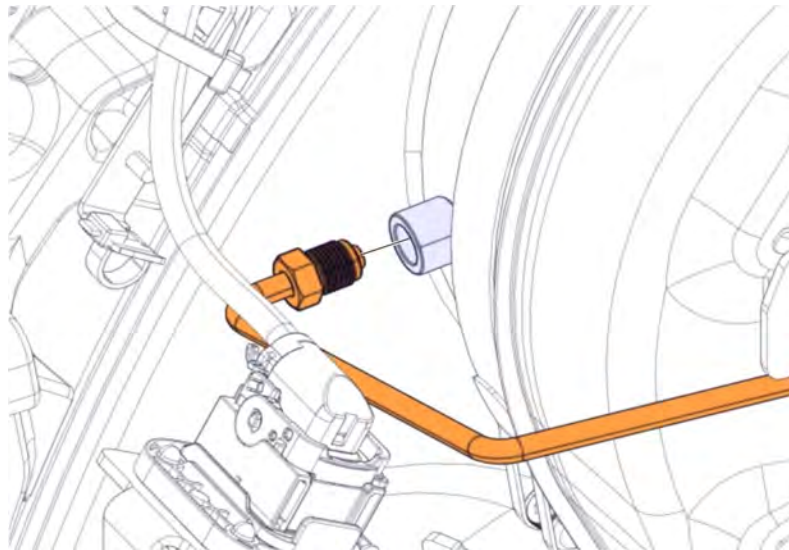

T2167951

20 Disconnect the connector.

21 Remove the cable ties as needed.

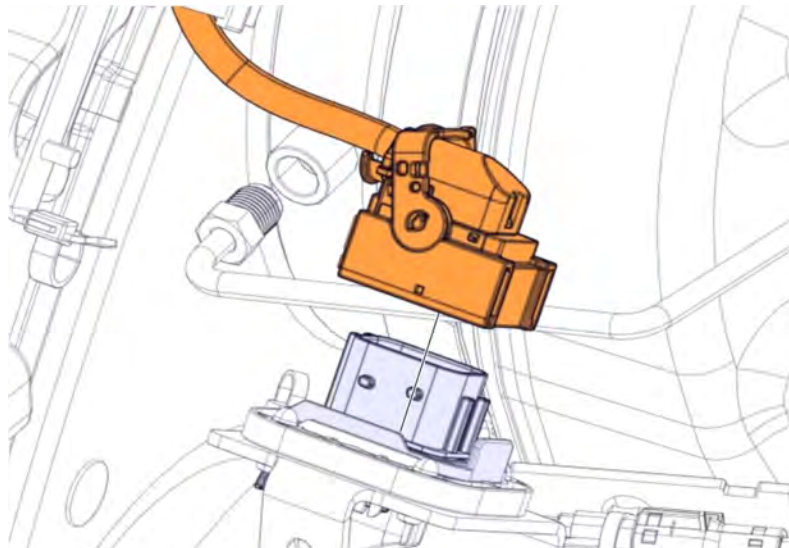

T2167952

22 Loosen the V-clamps.

Note: Clamps are one time use.

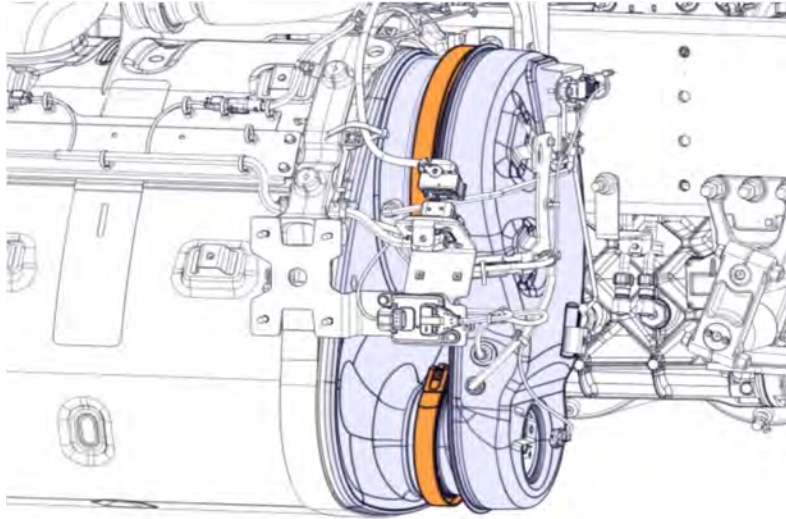

T2167953

23 Remove the cover.

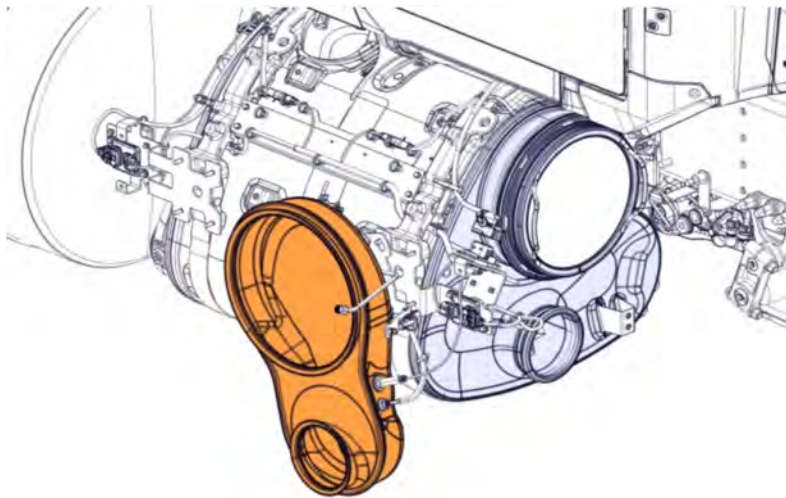

T2167954

24 Remove the V-clamps.

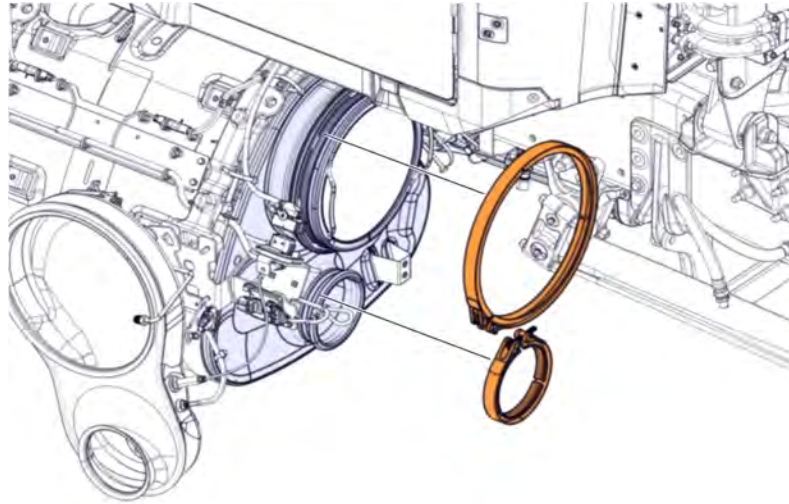

T2167955

25 Remove the gasket.

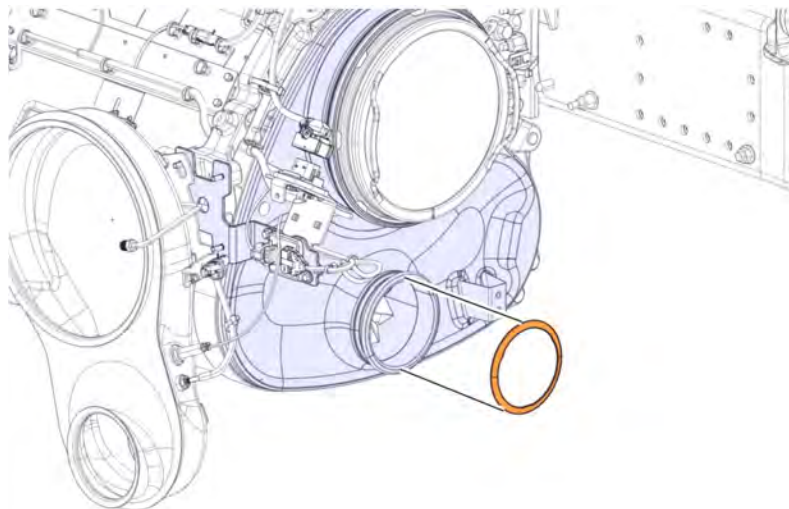

T2168764

26 Remove the filter.

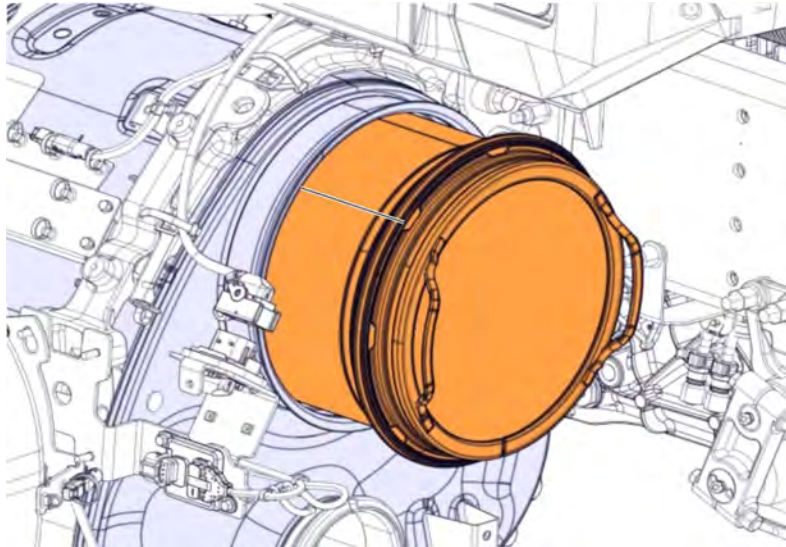

T2168765

27 Remove the gaskets.



T2168766

28 Clean the sealing surfaces.



T2168767

29 Install the gaskets.

Note: Use new gaskets.



T2168766

30 Install the filter.

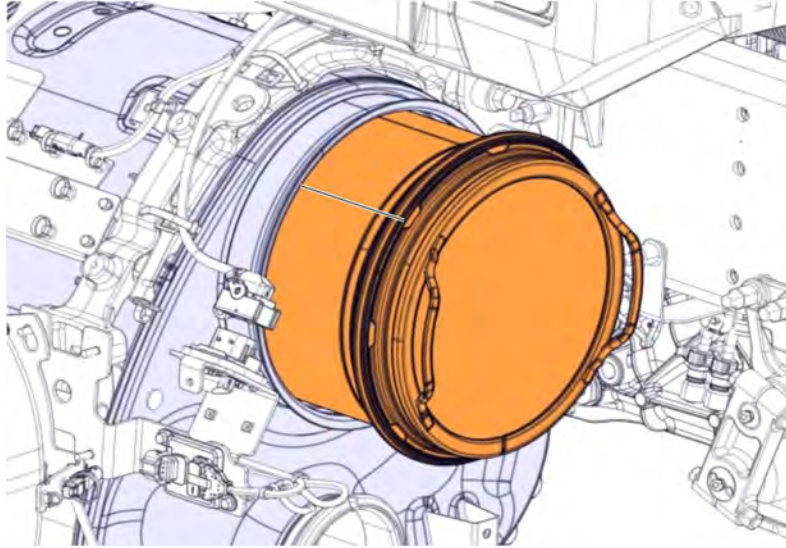

T2168765

31 Clean the mixer.

Note: Use a damp cloth to remove residue from the mixer.

Note: Do not use sharp objects to clean the mixer.

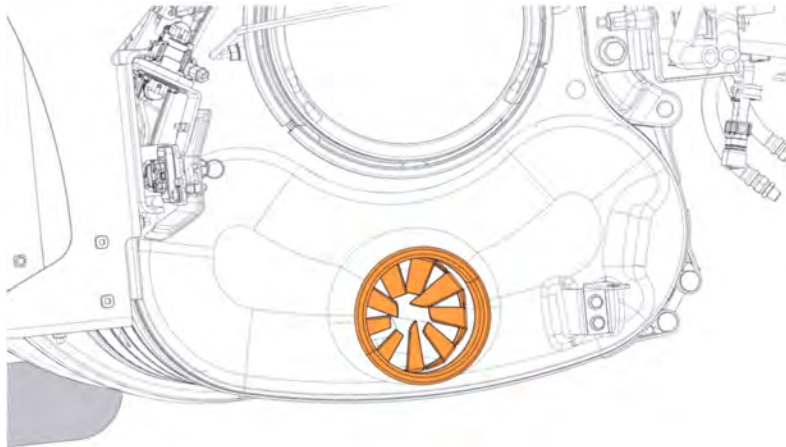

T2167957

32 Remove the tape from the gasket.

Note: Use a new gasket.

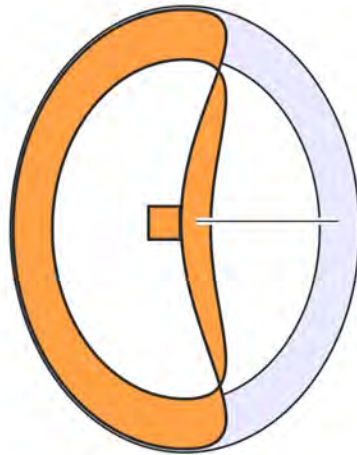

T2168768

33 Install the gasket.

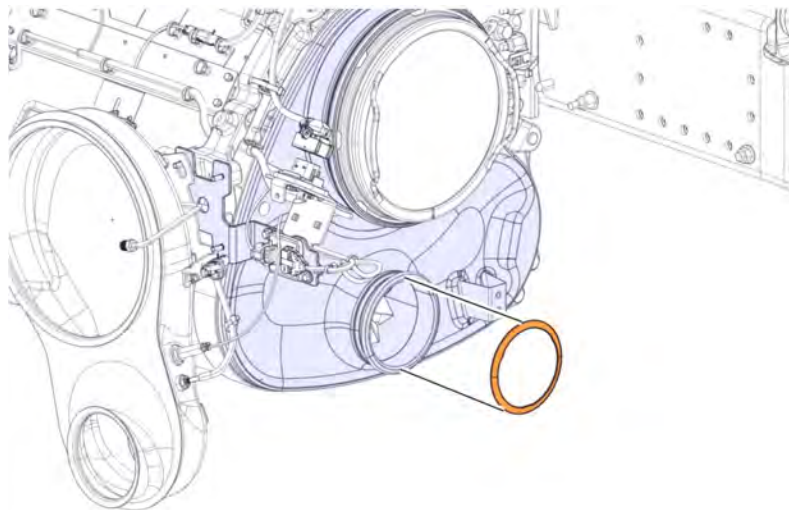

T2168764

34 Install the V-clamps.

Note: Use new V-clamps.

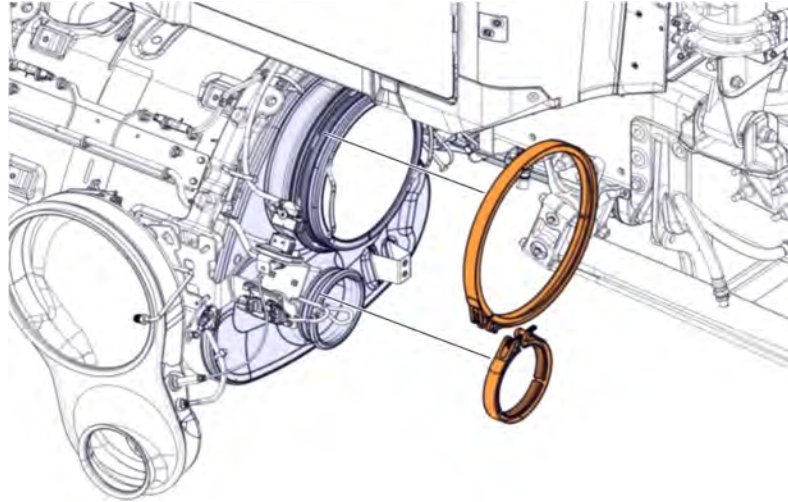

T2167955

35 Clean the sealing surface.

36 Clean any crystal build up from DPF end cover.

37 Install the cover.

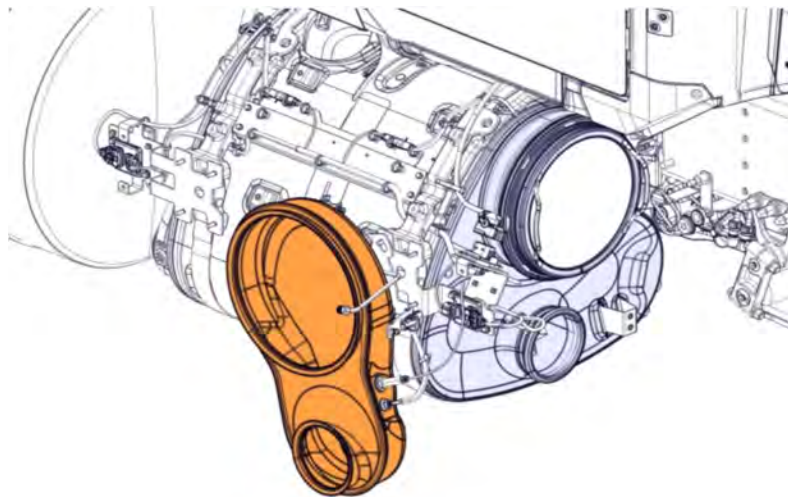

T2167954

38 Torque tighten the V-clamps to 15 ± 1 Nm (11 ± 0.75 lbf-ft).

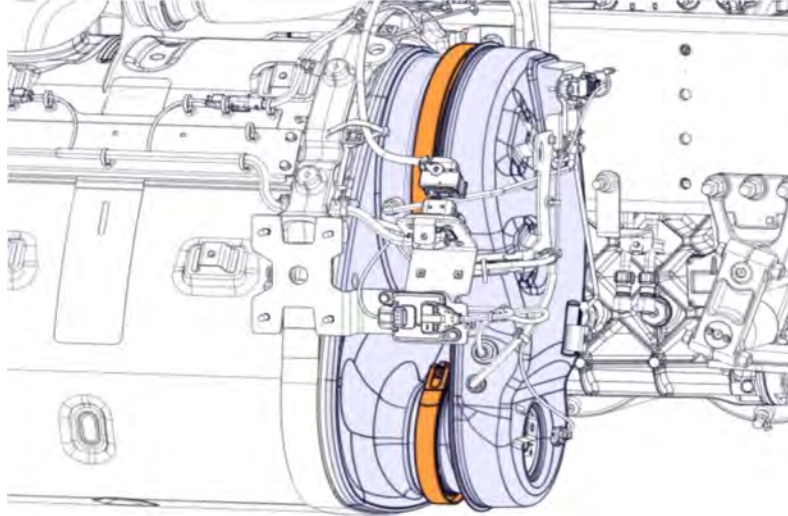

T2167953

39 Connect the connector.

40 Install cable ties as needed.

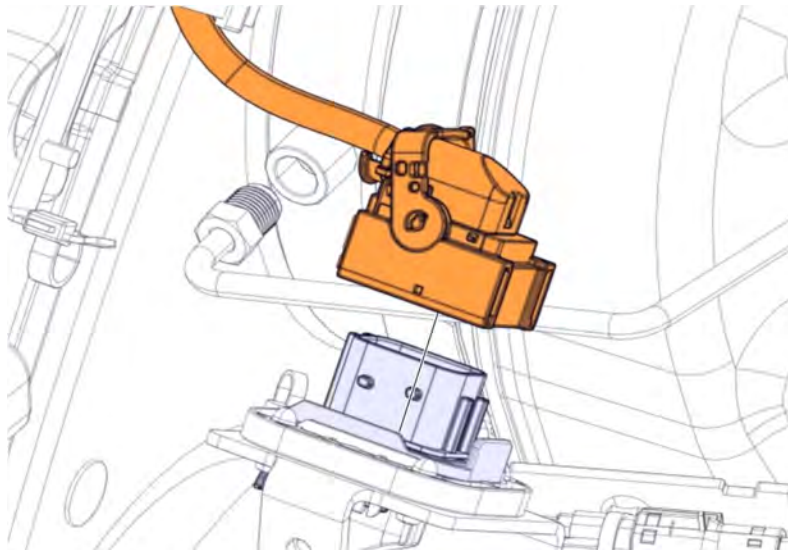

T2167952

41 Install the tube.

42 Torque tighten the fitting to 30 ± 5 Nm (22 ± 4 lbf-ft).

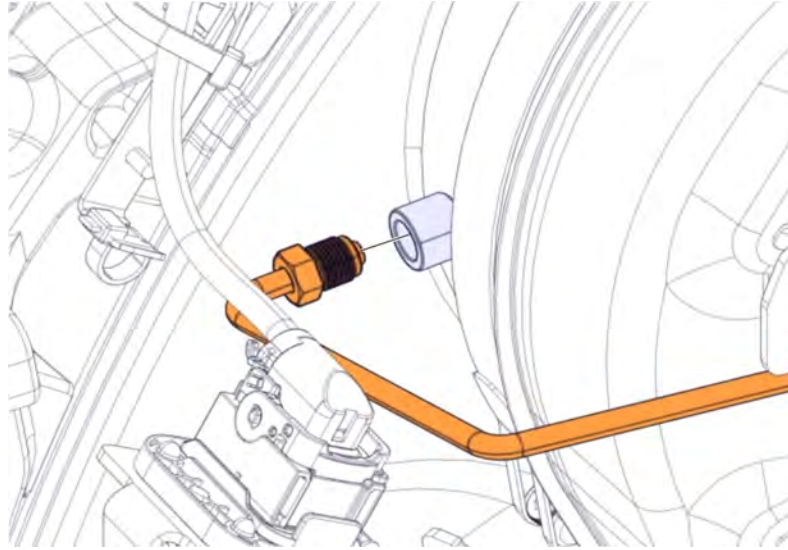

T2167951

43 Remove dosage valve from the bag.

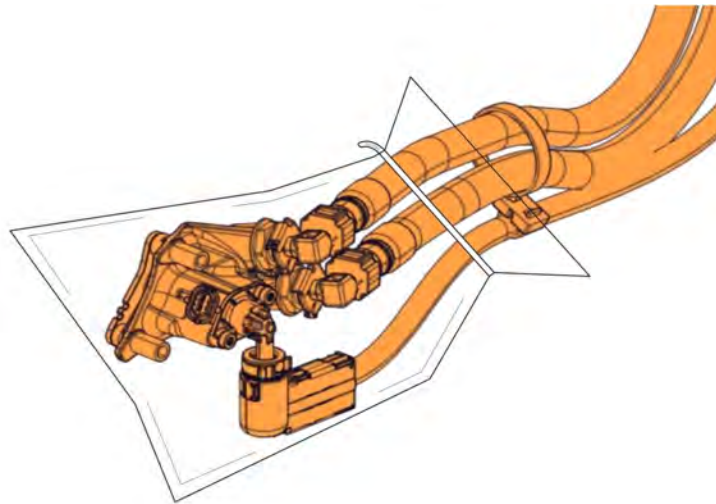

T2167950

44 Install the bracket.

45 Install the screws.

46 Torque tighten the screws.

- ▶ If M6 screws are used : 10 ± 1.5 Nm (7 ± 1 lbf-ft)
- ▶ If M8 screws are used : 24 ± 4 Nm (18 ± 3 lbf-ft)

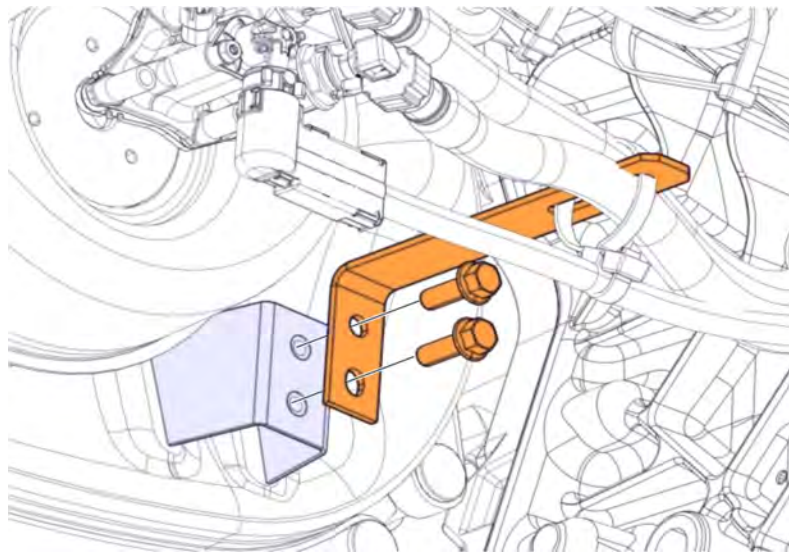

T2167949

47 Clean the nozzle.

Note: Use a damp cloth to remove residue from the nozzle tip.

Note: Do not use sharp objects to clean the tip.

48 Install the sealing plate.

Note: Use a new part.

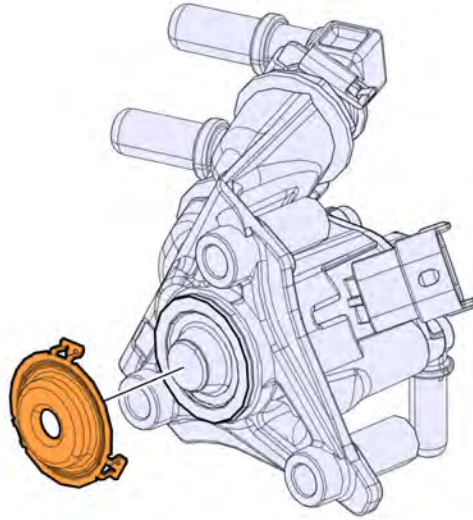

T2167948

49 Install the dosage valve.

Note: Do not install the gasket.

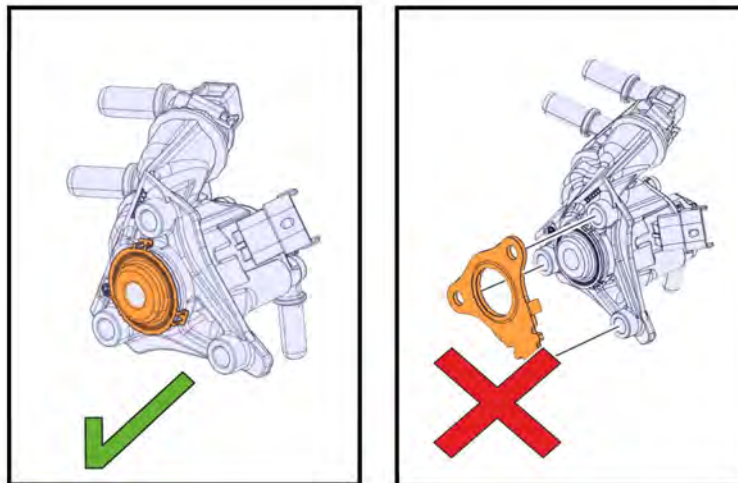

T2169407

50 Install the screws.

Note: Use new parts.

51 Torque tighten the screws to 10 ± 1.5 Nm (7 ± 1 lbf-ft)

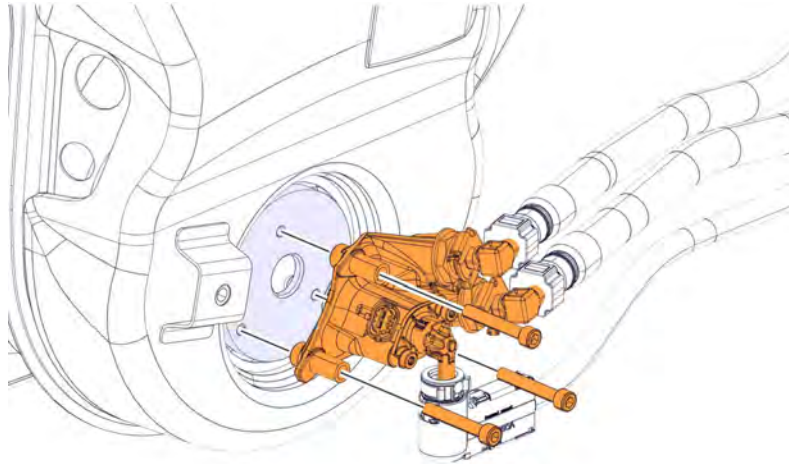

T2167960

52 Connect the connector.

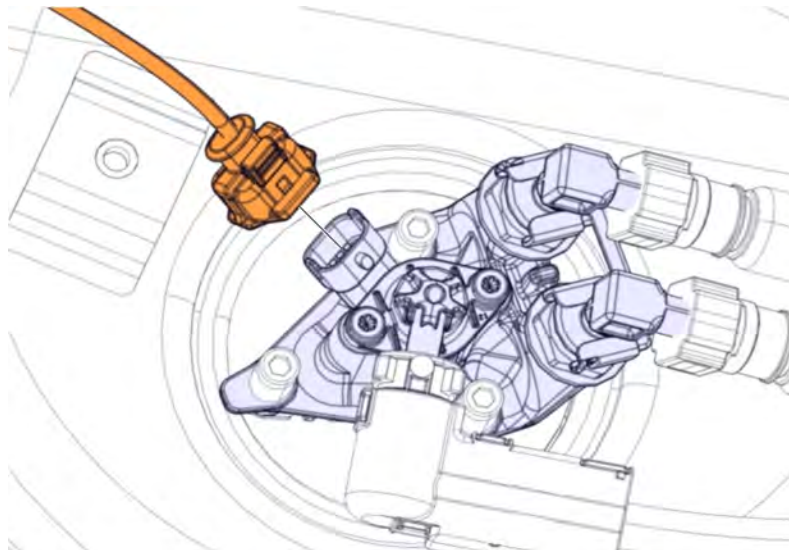

T2167946

53 Install the heat shields.

54 Install the chassis side fairing or step rail bracket assemblies.

55 Install the lower right splash shield.

56 Install the chassis side fairing or step rail assembly.

57 Lower the hood.

Note: Ensure that the hood is latched.

58 Connect the cable to the negative terminal.

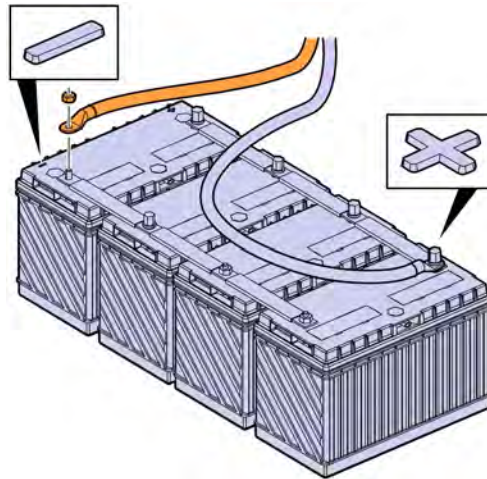

T3164283

59 Delete the diagnostic trouble codes according to the diagnostic tool instructions.

60 Perform Operation ID **2589-11-03-07, Sulfur Regeneration Service Information.**

61 Remove the wheel chocks.

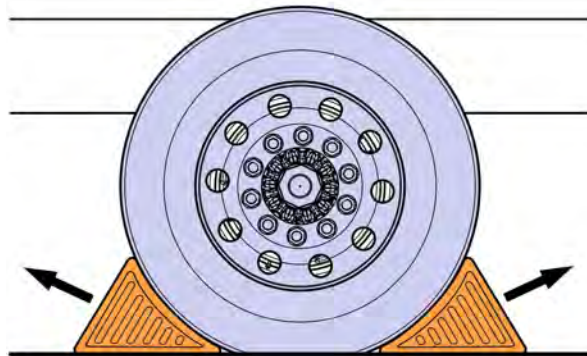

W7086759

Reimbursement

<p>This repair may be eligible for reimbursement if a product failure was experienced within time and mileage limits of the applicable Warranty coverage. Reimbursement is obtained via the normal claim handling process.</p>	<p>UCHP Reimbursement</p>
<p>Claim Type (used only when uploading from the Dealer Bus. Sys.)</p>	
<p>Labor Code</p>	
<p>Primary Labor Code Diesel exhaust fluid (DEF) crystallization, dosing valve, clean</p> <p>Sulfur Regeneration Service Information</p>	<p>2584-11-09-02 (1.5 hrs)</p> <p>2589-11-03-07 (1.2 hrs)</p>
<p>Causal Part</p>	<p>22677399</p>

MACK Trucks North America reserves the right to make any changes in design or to make additions to or upon its products without incurring any obligations to install the same on vehicles previously built.