

March 26, 2021

Version 1

Warranty Extension: 2014 Accord Plug-In Hybrid (PHEV) High Voltage Battery Pack Deterioration

AFFECTED VEHICLES

Year	Model	Trim	VIN Range
2014	Accord Plug-In Hybrid (PHEV)	ALL	Check the iN VIN status for eligibility.

BACKGROUND

Due to the possibility of early deterioration of the high-voltage battery, American Honda is extending the warranty coverage on these batteries to 12 years from the original date of purchase or 200,000 miles, whichever comes first.

CUSTOMER NOTIFICATION

Owners of affected vehicles will be sent a notification of this campaign.
Do an iN VIN status inquiry to make sure the vehicle is shown as eligible.

CORRECTIVE ACTION

Do an inspection and if necessary, replace the high-voltage battery pack.

NOTE: Update the high-voltage battery BCM software before doing this repair. Refer to service bulletin 21-037, *Emissions Recall: 2014 Accord Plug-In Hybrid (PHEV) Battery Software Update*.

PARTS INFORMATION

NOTE: Each 2014 Accord Plug-In Hybrid replacement high-voltage lithium ion battery assembly order includes the loan of a special tool kit that includes the tools required for the battery replacement procedure. For battery ordering, handling, and return information, Refer to Parts Information Bulletin 13-0003, *Lithium Ion Battery Exchange Program, 2014 Accord Plug-In*.

Part Name	Part Number	Quantity
High-Voltage Battery Pack	1D100-5K0-A00	1
Flange Bolt (8 x 20 mm)	90081-T3V-A00	8
Flange Bolt (8 x 45 mm)	90082-T3V-A00	2
Flange Bolt (10 x 50 mm)	90101-T3V-A00	2

CUSTOMER INFORMATION: The information in this bulletin is intended for use only by skilled technicians who have the proper tools, equipment, and training to correctly and safely maintain your vehicle. These procedures should not be attempted by "do-it-yourselfers," and you should not assume this bulletin applies to your vehicle, or that your vehicle has the condition described. To determine whether this information applies, contact an authorized Honda automobile dealer.

TOOL INFORMATION

NOTE: Each 2014 Accord Plug-In Hybrid replacement high-voltage lithium ion battery assembly order includes the loan of a special tool kit that includes the tools required for the battery replacement procedure. For tool handling and return information, Refer to 14-011, *High Voltage Lithium Ion Battery Replacement Equipment (2014 Accord Plug-In)*.

Tool Name	Part Number	Quantity
Accord PHEV Battery R&R Equipment Loan Kit	07PHEVBATOLKIT	1

WARRANTY CLAIM INFORMATION

Operation Number	Description	Flat Rate Time	Defect Code	Symptom Code	Template ID	Failed Part Number
1185B8	All DTC Check (includes charging and test-drive).	0.6 hr.	6B600	NA700	A21038A	1D100-5K0-A00
A	Replace the high-voltage battery pack.	3.5 hr.				

Skill Level: Repair Technician

INSPECTION PROCEDURE

Do an all DTC check and confirm DTC P0A7F (High Voltage Battery Capacity Serious Deterioration). If the DTC is found, clear the DTC, and charge the HV battery to 100% SOC. Drive the vehicle at approximately 30mph for at least 5 minutes. If the DTC recodes, replace the high voltage battery. If the DTC does not recode, follow normal system troubleshooting.

REPAIR PROCEDURE

NOTE: Refer to the service information for detailed images.

1. Turn off the main switch to the high voltage circuit. Refer to the service information.
2. From the cabin side, remove the right side cover, and disconnect the high voltage connectors and battery lead caps.
3. Disconnect the left lower IPU harness connectors.
4. Disconnect the right lower IPU harness connector.
5. Disconnect the IPU upper harness connectors and remove the harness clamp.
6. Remove the ground cable.
7. Disconnect the high voltage motor power inverter module cable connector and remove the harness clamp.
8. Remove the harness clamp, then disconnect the D/V 12 volt plus cable and the ground cable.
9. Remove the junction board cover.
10. Remove the right air inlet trim, right battery inlet duct, and DC-DC inlet duct.

11. Disconnect the high voltage cable terminals, and remove the harness clamps.

NOTE: Take note of the color bands on the cables red and blue and their positions before disconnecting the cables.

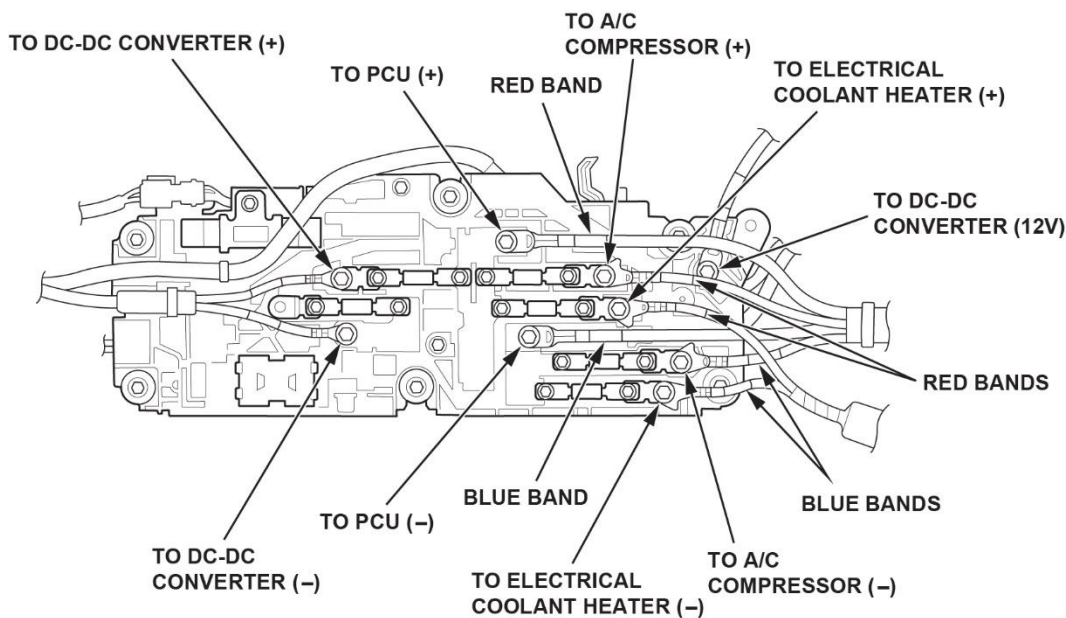

12. Remove the trunk floor cover, the trunk rear trim panel, the trunk tool box, the trunk front trim panel, and the trunk rear side trim panel.

13. From the trunk side, remove the IPU guard.

14. Remove the DC-DC fan outlet duct, the rear DC-DC inlet duct, and the harness clamp.

15. Remove the bolts that hold the battery pack upper component from the cabin side. From the trunk side remove the bolts, then carefully remove the battery pack upper component from the trunk.

16. Battery Pack A removal: From the cabin side, disconnect the high voltage motor power inverter module cable terminals and remove the harness clamps, then remove the junction board connector bracket.

NOTE: Take note of the color bands on the cables red and blue and their positions before disconnecting the cables.

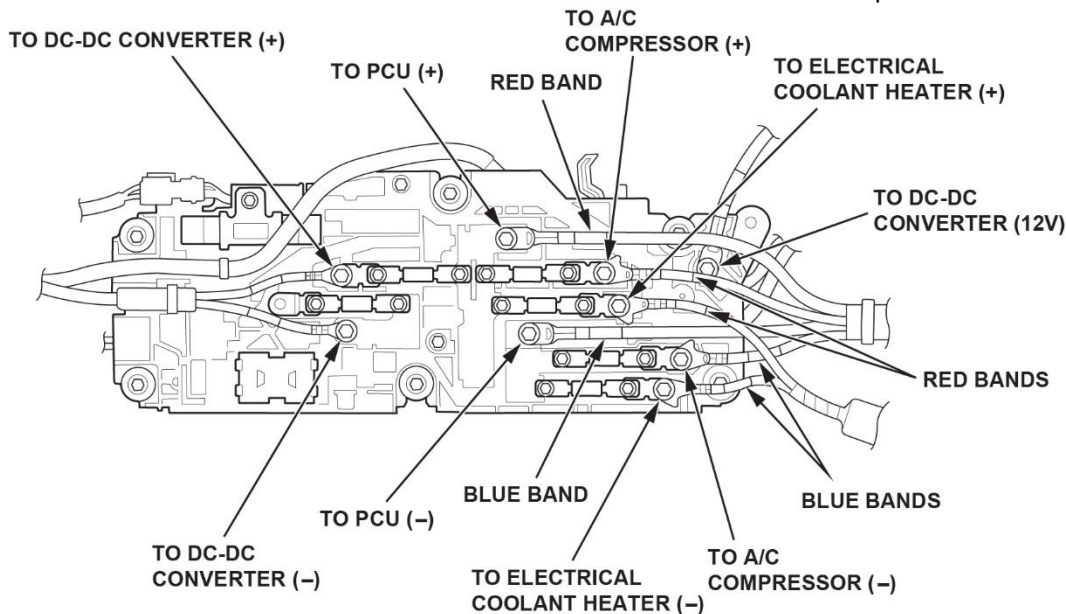

17. Disconnect the right lower IPU harness connector.
18. Remove the junction board connector bracket.
19. Disconnect the battery system leak sensor connector.
20. Remove the junction board.
21. From the trunk side, remove the charge rail plates and the battery insulator.
NOTE: Squeeze inward on the ends of the charge rail plates to release the lock tabs.
22. Remove the left battery outlet duct and the right battery outlet duct.
23. From the cabin side, disconnect the right IPU lower harness connector and remove the harness clamps.
24. Disconnect the right side wire harness connector.
25. Remove the upper front bracket and the harness clamps.
26. From the trunk side, disconnect the left IPU lower harness connector.
27. From the cabin side, remove the left IPU upper mounting bracket and the right IPU upper mounting bracket.

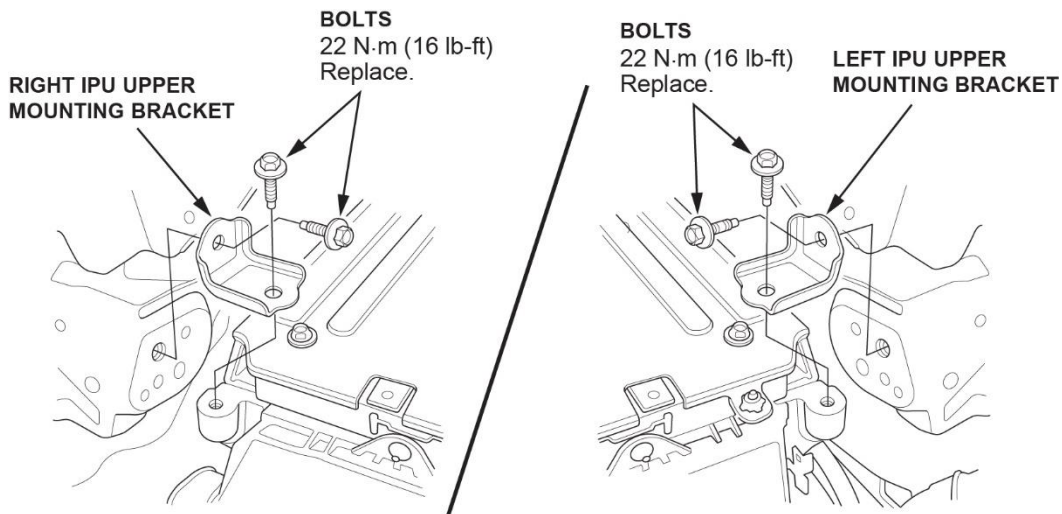

28. To remove battery pack A, remove the 6 battery mounting bolts. There will be an additional 6 battery mounting bolts that cannot be removed, loosen them and lift-up the bolts one at time and install an 80 mm long slit plastic tube around each of the bolts. Refer to the service information for images.

NOTE:

- The slit plastic tubes are included in the Accord PHEV Battery R&R Equipment Loan Kit (07PHEVBATOLKIT).
- The plastic tubes keep the mounting bolts up and out of way to allow battery pack A to slide out.

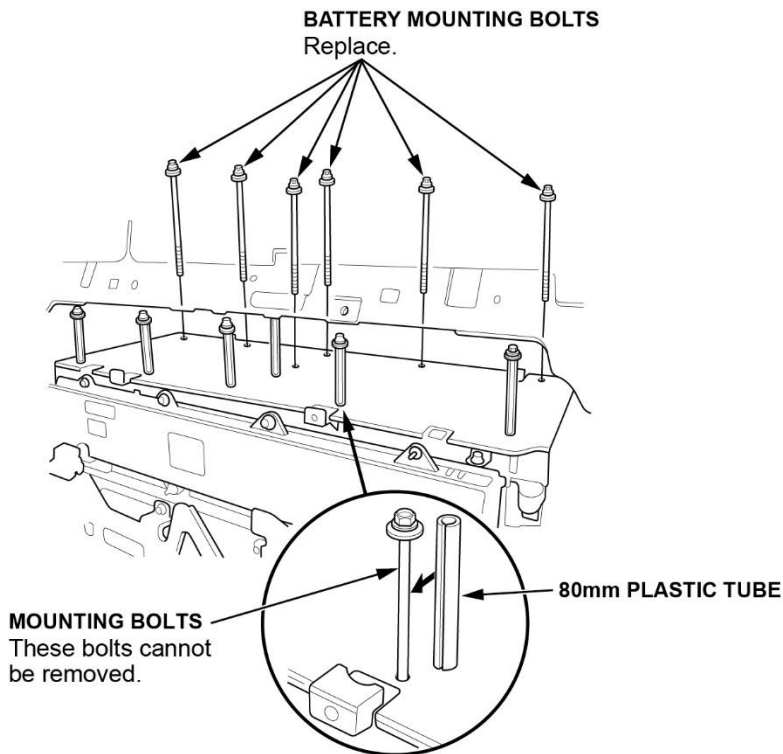

29. Place fender covers over the rear fenders and the trunk opening to avoid damaging the vehicle. Attach the battery removal/installation carrier onto battery pack A. Loosely tighten the bolts.
30. Install the carrier adapter mount with the "A" mark side to the right rear battery pack mount. Loosely tighten the bolts, then tighten the five bolts to **24.4 N·m (18 lb·ft)**.
31. Install the inside handle to the battery removal/installation carrier and install the pin. Set the battery removal/installation table in the trunk area with the table legs extended.
32. With the help of an assistant on the inside of the vehicle, carefully lift and transfer battery pack A onto the battery removal/installation table. Remove the inside handle from the battery pack removal/installation carrier
33. With the help of an assistant at the rear of the vehicle, carefully lift the battery pack A and remove it from the trunk area. Set the battery pack on the work surface provided with the Accord PHEV Battery R&R Equipment Loan Kit (07PHEVBATOLKIT).
34. Battery Pack B removal: From the cabin side, remove the DC cable bracket.
35. Disconnect the leak sensor connector and remove the leak sensor.
36. Disconnect the left side wire harness connector and remove the left IPU side cover.
37. Remove the left air inlet trim and the left battery inlet duct.

38. From the trunk side, remove the IPU lower mounting brackets.

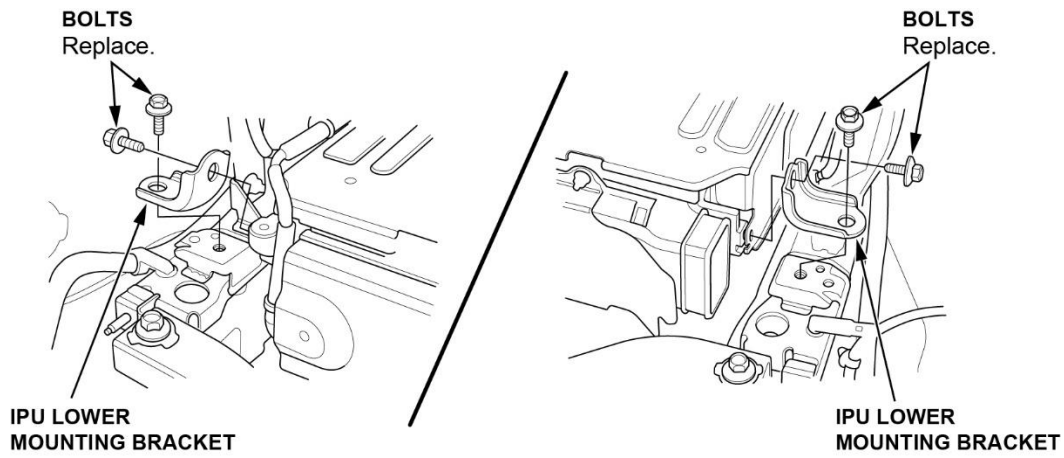

39. From the cabin side, remove the IPU center frame bolts and the harness clamp.

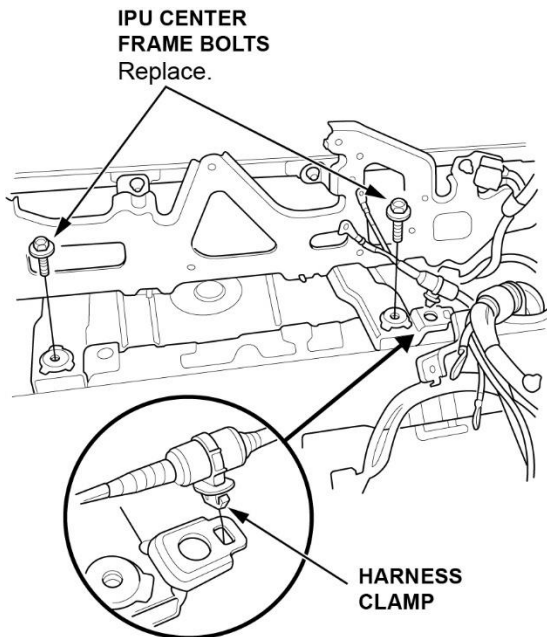

40. From the trunk side, remove the IPU rear cross member bolts.

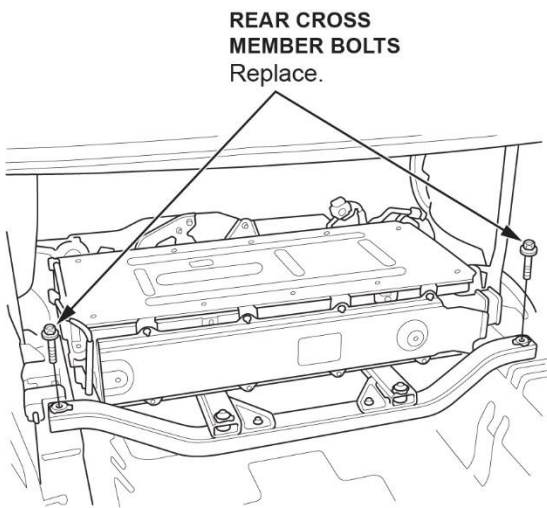

41. Place fender covers over the rear fenders and the trunk opening to avoid damaging the vehicle. Attach the battery removal/installation carrier onto battery pack. Loosely tighten the bolts.
42. Install the carrier adapter mount with the "B" mark side to right rear battery pack mount. Loosely tighten the bolts then tighten the five bolts to **24.4 N·m (18 lb·ft)**.
43. Install the inside handle to the battery removal/installation carrier and install the pin. Set the battery removal/installation table in the trunk area as shown (table legs folded).
44. With the help of an assistant on the inside of the vehicle, carefully lift and transfer battery pack B onto the battery removal/installation table. Remove the inside handle from the battery pack removal/installation carrier
45. With the help of an assistant at the rear of the vehicle, carefully lift the battery pack B and remove it from the trunk area. Set the battery pack on the work surface provided with the Accord PHEV Battery R&R Equipment Loan Kit (07PHEVBATOLKIT).
46. If needed, flip the battery pack upside-down, and remove the IPU center frame.
47. Transfer over the IPU harnesses from the old battery packs to the new battery packs.
48. First install battery pack B, then battery pack A in the reverse order of removal.
Note: Make sure to torque all bolts to the torque specification shown in the service information.
49. Install the remaining parts in the reverse order of removal.
50. Turn on the main switch to the high voltage circuit. Refer to the service information.
51. Do an all DTC check.
52. Do a Battery Condition Monitor Module Reset. Refer to the service information.
53. Fully charge the high-voltage battery then, test-drive the vehicle and confirm no DTCs are set.

END