

Technical Service Bulletin

Mazda North American Operations
Irvine, CA 92618-2922



Subject: MAZDA SERVICE PROGRAM (MSP49) - CREAKING / SQUEAKING NOISE FROM RIGHT REAR SUSPENSION	Bulletin No.: 02-005/21
	Last Issued : 03/25/2021

BULLETIN NOTES

This bulletin supersedes the previously issued bulletin(s) listed below. The changes are noted in Red text.

Previous TSBs:	Date(s) Issued:
02-004/18	02/14/18
02-004/17	01/13/17 and 03/01/17

APPLICABLE MODEL(S)/VINS

2016-2017 CX-9 vehicles built from February 11, 2016 through November 8, 2016

- 2016 VIN Range: JM3TC****G0 100053 – 127083
- 2017 VIN Range: JM3TC****H0 127084 – 127908

DESCRIPTION

Certain CX-9 vehicles may experience a creaking/squeaking noise from the right rear suspension. The noise may occur while traveling at lower speeds or coming to a stop, or when starting from a stop. The noise can also be duplicated by gently bouncing the right rear suspension (i.e. simulating the movement of a passenger exiting the right rear door).

The creaking noise may be caused by stick-slip between the upper spring seat rubber and the coil spring.

NOTE:

- **UNDER THE MAZDA SERVICE PROGRAM (MSP49), ALL CURRENT DEALER INVENTORY AND RETAILED VEHICLES FOUND TO BE WITHIN THE ABOVE VIN AND PRODUCTION DATES RANGES MUST BE REPAIRED ACCORDING TO THE INSTRUCTIONS CONTAINED IN THIS SERVICE BULLETIN.**
- **BEFORE PERFORMING ANY REPAIR, VALIDATE THE VEHICLE IS APPLICABLE TO THIS PROGRAM BY PERFORMING AN "eMDCS WARRANTY VEHICLE INQUIRY" AND VERIFYING THE VEHICLE DISPLAYS CAMPAIGN "MSP49" AND ITS CAMPAIGN STATUS DISPLAYS "OPEN". SEE "VEHICLE INSPECTION PROCEDURE" BELOW.**
- Some vehicles have already been repaired under Technical Service Bulletin 02-004/17, 02-004/18 or by normal warranty claim. These vehicles will **NOT** display the MSP49 campaign in eMDCS as those vehicles will be removed from this service program.

DEALER INVENTORY:

Repair all applicable vehicles currently in dealer inventory according to the procedures contained in this service bulletin.

Page 1 of 8

CONSUMER NOTICE: The information and instructions in this bulletin are intended for use by skilled technicians. Mazda technicians utilize the proper tools/ equipment and take training to correctly and safely maintain Mazda vehicles. These instructions should not be performed by "do-it-yourselfers." Customers should not assume this bulletin applies to their vehicle or that their vehicle will develop the described concern. To determine if the information applies, customers should contact their nearest authorized Mazda dealership. Mazda North American Operations reserves the right to alter the specifications and contents of this bulletin without obligation or advance notice. All rights reserved. No part of this bulletin may be reproduced in any form or by any means, electronic or mechanical--including photocopying and recording and the use of any kind of information storage and retrieval system ---without permission in writing.

RETAIL VEHICLES:

When an applicable retailed vehicle is brought into the dealer for any type of repair or scheduled maintenance, review the "Warranty Vehicle Inquiry" page in eMDCS to check the status of MSP49. If the status is "OPEN" for MSP49, repair the vehicle according to the procedures contained in this service bulletin.

VEHICLE INSPECTION PROCEDURE

1. Verify the vehicle is within one of the following VIN ranges:

2016 - 2017 CX-9 vehicles built from February 11, 2016 through November 8, 2016

- 2016 VIN Range: JM3 TC**** G0 100053 – 127083
- 2017 VIN Range: JM3 TC**** H0 127084 – 127908

- If the vehicle is within the above VIN and production date ranges, proceed to Step 2.

- If the vehicle is not within the above VIN and production date ranges, return the vehicle to the customer or inventory.

2. Perform a Warranty Vehicle Inquiry using your eMDCS System and inspect the vehicle for a Campaign Label MSP49 attached either to the vehicle's bulkhead or to the vehicle's hood.

CONSUMER NOTICE: The information and instructions in this bulletin are intended for use by skilled technicians. Mazda technicians utilize the proper tools/ equipment and take training to correctly and safely maintain Mazda vehicles. These instructions should not be performed by "do-it-yourselfers." Customers should not assume this bulletin applies to their vehicle or that their vehicle will develop the described concern. To determine if the information applies, customers should contact their nearest authorized Mazda dealership. Mazda North American Operations reserves the right to alter the specifications and contents of this bulletin without obligation or advance notice. All rights reserved. No part of this bulletin may be reproduced in any form or by any means, electronic or mechanical---including photocopying and recording and the use of any kind of information storage and retrieval system ---without permission in writing.

Refer to eMDCS System - Warranty Vehicle Inquiry Results table below.

NOTE: Verify the campaign number as the vehicle may have multiple labels.

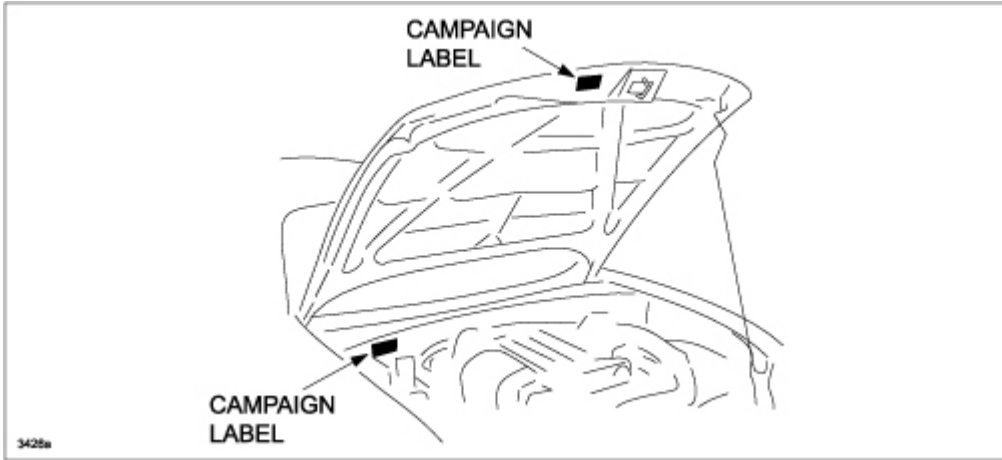

eMDCS System - Warranty Vehicle Inquiry Results:

If eMDCS displays:	Campaign Label is:	Action Required:
"Campaign: MSP49 Open"	Present	Contact the Warranty Hotline at (877) 727-6626, option 3 to update vehicle history
"Campaign: MSP49 Open"	Not Present	Proceed to "REPAIR PROCEDURE"
"Campaign: MSP49 Closed"	Present	Return vehicle to inventory or customer
"Campaign: MSP49 Closed"	Not present	Complete a label and apply it to vehicle's bulkhead or hood
"Campaign: MSP49 Open" or "Closed" is not displayed	Does not apply	Campaign does not apply to this vehicle. Return the vehicle to inventory or customer

CONSUMER NOTICE: The information and instructions in this bulletin are intended for use by skilled technicians. Mazda technicians utilize the proper tools/ equipment and take training to correctly and safely maintain Mazda vehicles. These instructions should not be performed by "do-it-yourselfers." Customers should not assume this bulletin applies to their vehicle or that their vehicle will develop the described concern. To determine if the information applies, customers should contact their nearest authorized Mazda dealership. Mazda North American Operations reserves the right to alter the specifications and contents of this bulletin without obligation or advance notice. All rights reserved. No part of this bulletin may be reproduced in any form or by any means, electronic or mechanical--including photocopying and recording and the use of any kind of information storage and retrieval system ---without permission in writing.

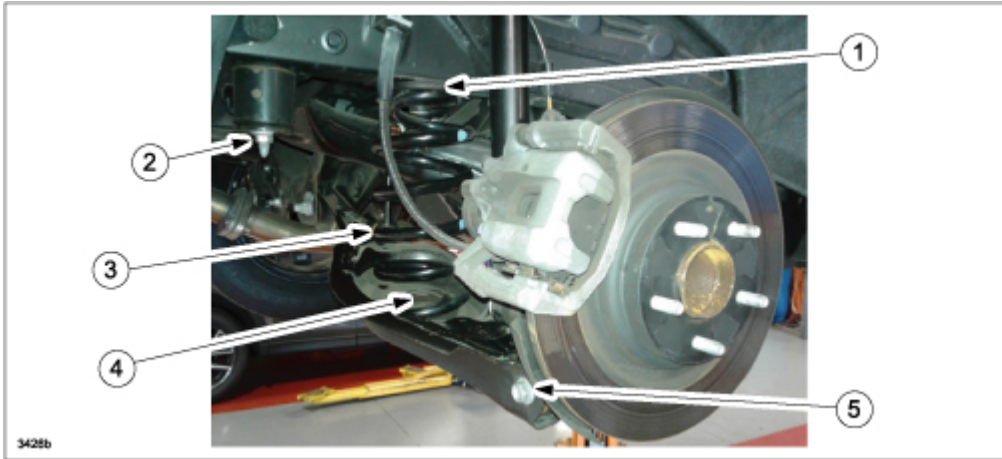
REPAIR PROCEDURE**RIGHT REAR COIL SPRING REMOVAL/INSTALLATION**

1	Upper spring seat rubber
2	Rear stabilizer control link lower side nut - 45-55 {4.6-5.6, 34-40}**
3	Rear coil spring
4	Lower spring seat rubber
5	Rear lower arm outer bolt - 127-154 {13-15, 94-113}**

** N-m {kgm-f, ft-lbf}

WARNING: Be careful, do not allow the coil spring to fly off when removing/installing the coil spring, otherwise, the coil spring could fly off and cause you serious injury or death.

CAUTION: Be careful, do not allow the coil spring to fly off when removing/installing the coil spring, otherwise, the coil spring could fly off and damage the vehicle.

1. Safely raise the vehicle with a lift.
2. Remove the right, rear wheel assembly.
3. Support the **right rear lower arm** with a jack (1).

CONSUMER NOTICE: The information and instructions in this bulletin are intended for use by skilled technicians. Mazda technicians utilize the proper tools/ equipment and take training to correctly and safely maintain Mazda vehicles. These instructions should not be performed by "do-it-yourselfers." Customers should not assume this bulletin applies to their vehicle or that their vehicle will develop the described concern. To determine if the information applies, customers should contact their nearest authorized Mazda dealership. Mazda North American Operations reserves the right to alter the specifications and contents of this bulletin without obligation or advance notice. All rights reserved. No part of this bulletin may be reproduced in any form or by any means, electronic or mechanical---including photocopying and recording and the use of any kind of information storage and retrieval system ---without permission in writing.

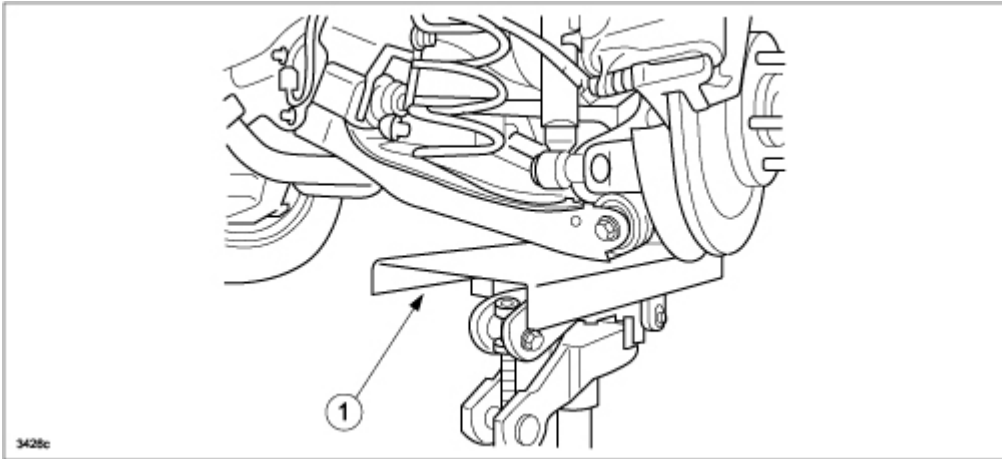

4. Remove the rear lower arm outer bolt.
5. Remove the rear coil spring (1).
6. Remove the upper spring seat rubber (2).
7. Install the upper spring seat rubber.

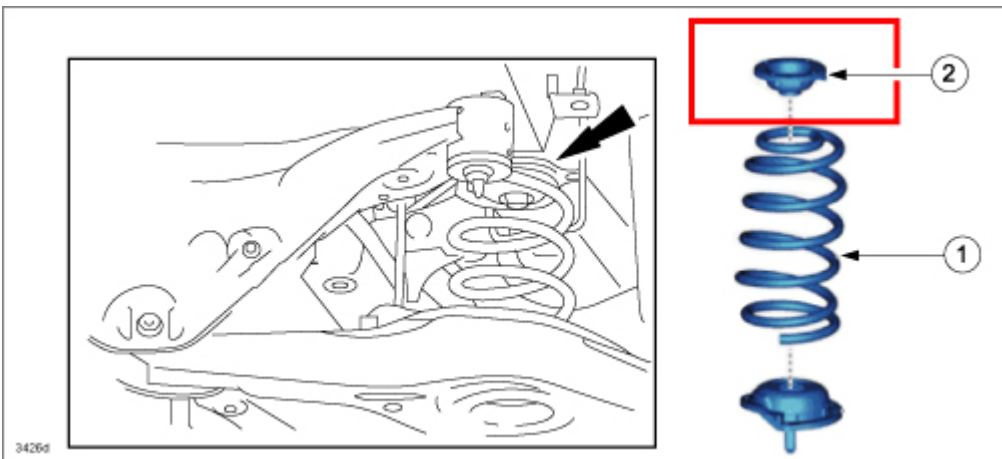

8. Install the rear coil spring with the spring oriented as shown below.
- NOTE:** Paint marks (1).

CONSUMER NOTICE: The information and instructions in this bulletin are intended for use by skilled technicians. Mazda technicians utilize the proper tools/ equipment and take training to correctly and safely maintain Mazda vehicles. These instructions should not be performed by "do-it-yourselfers." Customers should not assume this bulletin applies to their vehicle or that their vehicle will develop the described concern. To determine if the information applies, customers should contact their nearest authorized Mazda dealership. Mazda North American Operations reserves the right to alter the specifications and contents of this bulletin without obligation or advance notice. All rights reserved. No part of this bulletin may be reproduced in any form or by any means, electronic or mechanical---including photocopying and recording and the use of any kind of information storage and retrieval system ---without permission in writing.

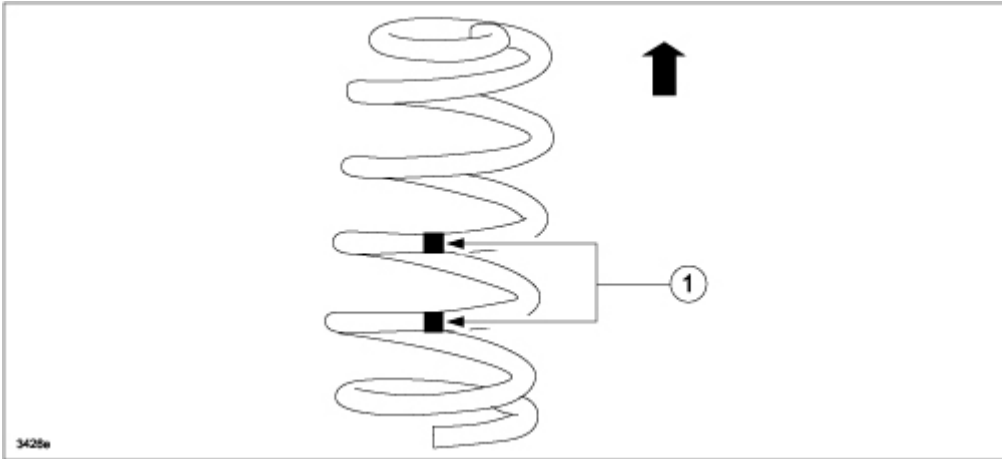

9. Align the upper end of the rear coil spring with the upper spring seat rubber.
10. Align the lower end of the rear coil spring with the step of the lower spring seat rubber.
11. When installing the joint section with a rubber bushing, perform the following procedures:
 - a. Temporarily tighten the bolt with the vehicle lifted up.
 - b. Lower the vehicle to the ground and tighten the bolt to the specified torque or position the jack (1) under the rear lower arm and jack up slowly.

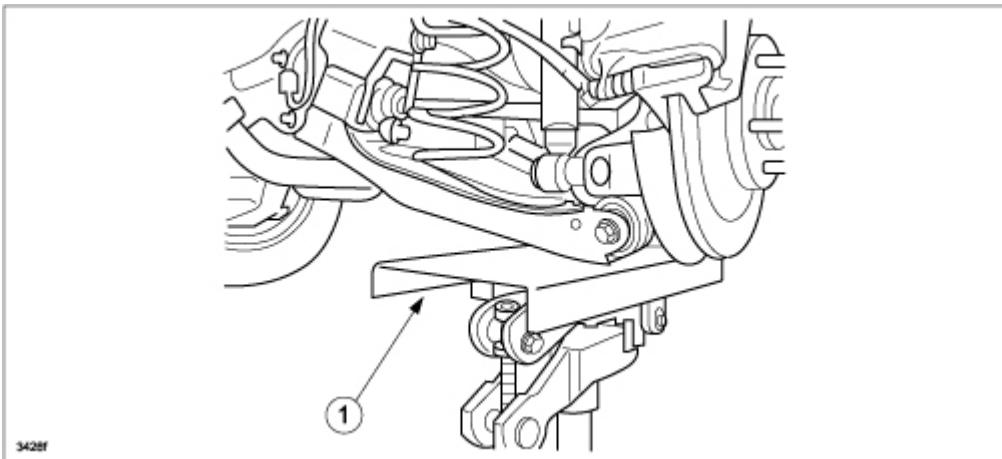

12. Tighten the rear lower arm outer bolt to the specified torque.
 - **Tightening Torque: 127-154 N-m {13-15 kgf-m, 94-113 ft-lbf}**

CAMPAIGN LABEL

1. Fill out a blue "Campaign Label" (9999-95-065A-06) with the Campaign No: "MSP49", your dealer code, today's date, and affix it to the vehicle's hood.

CONSUMER NOTICE: The information and instructions in this bulletin are intended for use by skilled technicians. Mazda technicians utilize the proper tools/ equipment and take training to correctly and safely maintain Mazda vehicles. These instructions should not be performed by "do-it-yourselfers." Customers should not assume this bulletin applies to their vehicle or that their vehicle will develop the described concern. To determine if the information applies, customers should contact their nearest authorized Mazda dealership. Mazda North American Operations reserves the right to alter the specifications and contents of this bulletin without obligation or advance notice. All rights reserved. No part of this bulletin may be reproduced in any form or by any means, electronic or mechanical--including photocopying and recording and the use of any kind of information storage and retrieval system ---without permission in writing.

CAMPAIGN LABEL	
CAMPAIGN NO:	_____
DEALER CODE:	_____
DATE:	//
P/N 9999-95-065A-05	
3426g	

2. Return the vehicle to the customer or dealer inventory.

PARTS INFORMATION

Part Number	Description	Qty.	Components
TKY8-28-01X	Rear coil spring kit (2WD)	1	Rear coil spring (TK48-28-01 1C) Upper spring seat rubber (K D35-28-012)
TKY0-28-01X	Rear coil spring kit (AWD)	1	Rear coil spring (TK50-28-01 1C) Upper spring seat rubber (KD 35-28-012)

WARRANTY INFORMATION

NOTE:

- This repair is covered under the Mazda New Vehicle Limited Warranty.
- **Pre-a uthorization** is required if the vehicle is outside the Mazda New Vehicle Limited Warranty.
- This repair is covered if the vehicle is outside the Mazda New Vehicle Limited Warranty, however, **pre-a uthorization** is required in order to process the claim.

Replace Right Rear Spring (2WD):

Process Number	AJ003A
Symptom Code	99
Damage Code	99
Part Number Main Cause	TKY8-28-01X
Quantity	1
Operation Number / Labor Hours:	XXP24ARX / 0.4 Hrs.

CONSUMER NOTICE: The information and instructions in this bulletin are intended for use by skilled technicians. Mazda technicians utilize the proper tools/ equipment and take training to correctly and safely maintain Mazda vehicles. These instructions should not be performed by "do-it-yourselfers." Customers should not assume this bulletin applies to their vehicle or that their vehicle will develop the described concern. To determine if the information applies, customers should contact their nearest authorized Mazda dealership. Mazda North American Operations reserves the right to alter the specifications and contents of this bulletin without obligation or advance notice. All rights reserved. No part of this bulletin may be reproduced in any form or by any means, electronic or mechanical--including photocopying and recording and the use of any kind of information storage and retrieval system ---without permission in writing.

Replace Right Rear Spring (AWD):

Process Number	AJ003A
Symptom Code	99
Damage Code	99
Part Number Main Cause	TKY0-28-01X
Quantity	1
Operation Number / Labor Hours:	XXP24BRX / 0.4 hrs

CONSUMER NOTICE: The information and instructions in this bulletin are intended for use by skilled technicians. Mazda technicians utilize the proper tools/ equipment and take training to correctly and safely maintain Mazda vehicles. These instructions should not be performed by "do-it-yourselfers." Customers should not assume this bulletin applies to their vehicle or that their vehicle will develop the described concern. To determine if the information applies, customers should contact their nearest authorized Mazda dealership. Mazda North American Operations reserves the right to alter the specifications and contents of this bulletin without obligation or advance notice. All rights reserved. No part of this bulletin may be reproduced in any form or by any means, electronic or mechanical---including photocopying and recording and the use of any kind of information storage and retrieval system ---without permission in writing.