

JLRTB02043NAS2

**TECHNICAL BULLETIN**

30 MAR 2021



© Jaguar Land Rover North America, LLC

NOTE: The information in Technical Bulletins is intended for use by trained, professional Technicians with the knowledge, tools, and equipment required to do the job properly and safely. It informs these Technicians of conditions that may occur on some vehicles, or provides information that could assist in proper vehicle service. The procedures should not be performed by 'do-it-yourselfers'. If you are not a Retailer, do not assume that a condition described affects your vehicle. Contact an authorized Land Rover service facility to determine whether this bulletin applies to a specific vehicle.

## INFORMATION

**This reissue replaces all previous versions. Please destroy all previous versions.**

This bulletin supersedes TSB JLRTB02043NAS1/2020 dated 09 JUN 2020, which should either be destroyed or clearly marked to show it is no longer valid (e.g. with a line across the page). Only refer to the electronic version of this Technical Bulletin in TOPIx.

Changes are highlighted in blue

## SECTION:

501-08

## SUBJECT/CONCERN:

Air Deflector Loose/Adrift

## AFFECTED VEHICLE RANGE:

MODEL:	MODEL YEAR:	VIN:	ASSEMBLY PLANT:
I-PACE (X590)	2019-2020	F60001-F81898	Graz (Austria)

MODEL:	MODEL YEAR:	VIN:	ASSEMBLY PLANT:
I-PACE (X590)	2020-2021	600001-612710	Graz (Austria)

**MARKETS:**

NORTH AMERICA

**CONDITION SUMMARY:****SITUATION:**

1 or both of the air deflectors installed on the rocker panel moldings may become loose/adrift over time. They may rotate around the retaining scrivet and come in contact with the rear tires, causing a rubbing noise.

**CAUSE:**

Retention loads lower than expected.

**ACTION:**

Follow the instructions below.

**PARTS:****NOTE:**

Only install a new air deflector if the original air deflector is damaged or missing.

PART NUMBER	DESCRIPTION	QUANTITY
C2S9354020	Retaining scrivets (up to 4 new retaining scrivets may be required if installing 2 new air deflectors)	2/3/4
T4K9937	Left air deflector (if required)	1
T4K9936	Right air deflector (if required)	1

**WARRANTY:**

**NOTES:**

- Repair procedures are under constant review, and therefore times are subject to change; those quoted here must be taken as guidance only. Use TOPIx to obtain the latest repair time.
- The JLR claims submission system requires the use of causal part numbers. Labor only claims must show the causal part number with a quantity of zero.

DESCRIPTION	SRO	TIME (HOURS)	CONDITION CODE	CAUSAL PART
JLRTB02043 - Air deflector modification	99.01.16	0.2	DS	T4K9937/T4K9936

**NOTE:**

Normal Warranty procedures apply.

**SERVICE INSTRUCTION:**

1. Raise and support the vehicle (see TOPIx Workshop Manual section 100-02: Jacking and Lifting - Description and Operation - Jacking and Lifting).

**Vehicles that require a new air deflector only**

2.

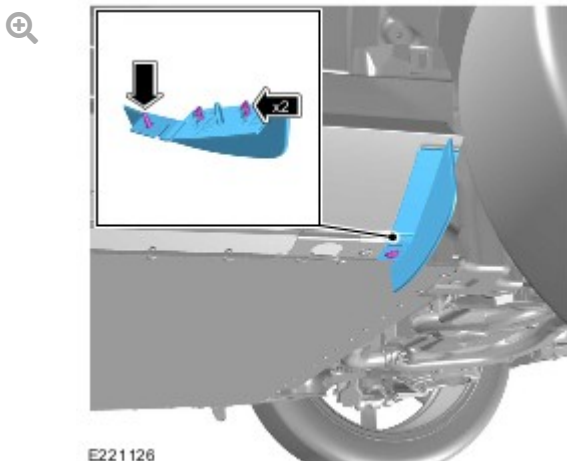

E221126

Install the new left air deflector.

- Secure the 2 retaining clips.
- Install the retaining scrivet.

## All vehicles

---

3.

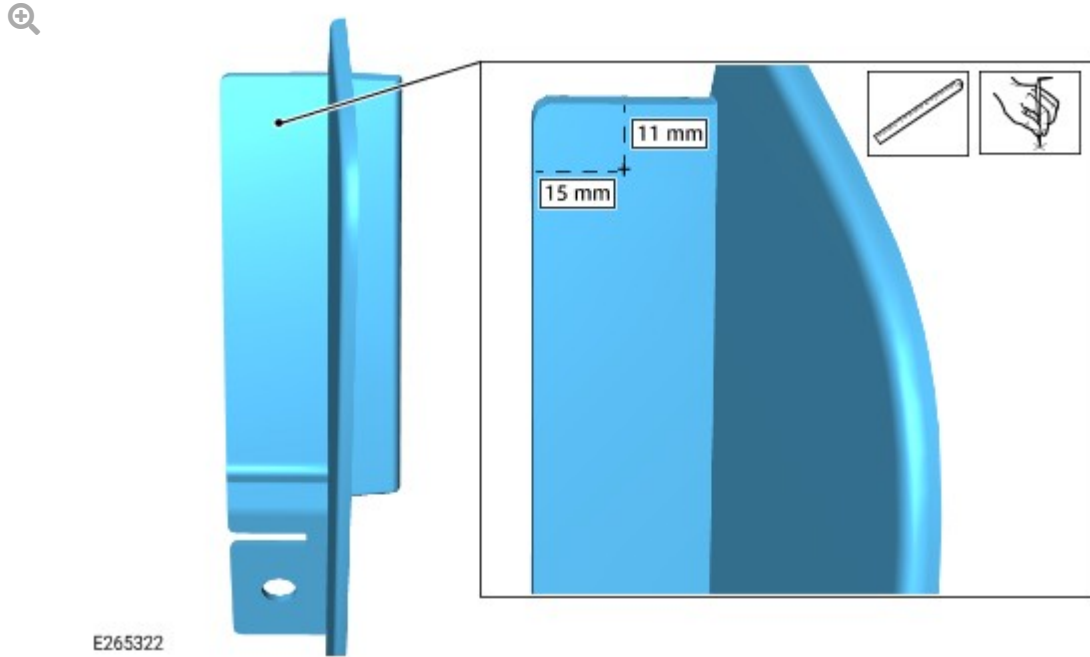

Measure and mark the position on the left air deflector for drilling, as shown in the illustration.

4.

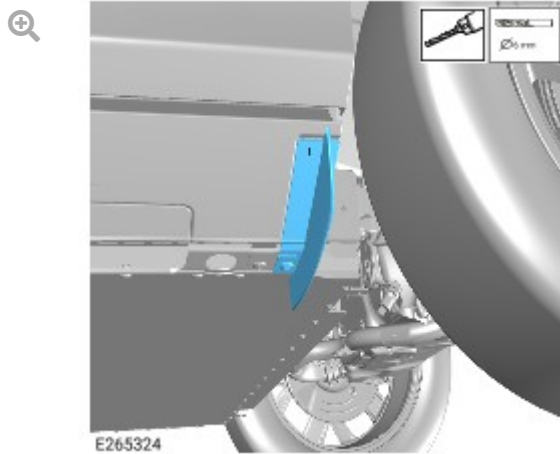

Using a 6 mm drill, create a hole through the left air deflector and the left rocker panel molding in the position marked during step 3.

---

5.

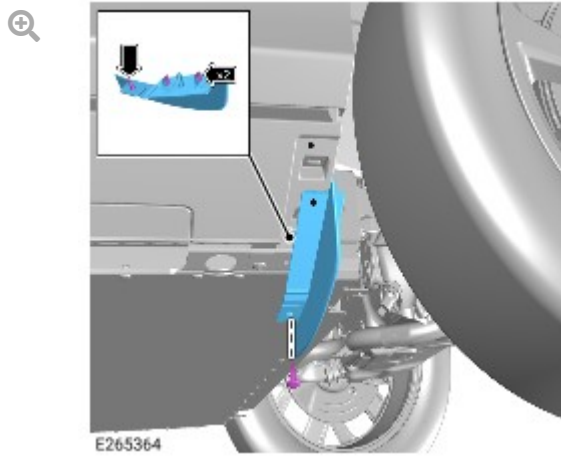

Remove the left air deflector.

- Remove the retaining scrivet.
- Release the 2 retaining clips.

6.

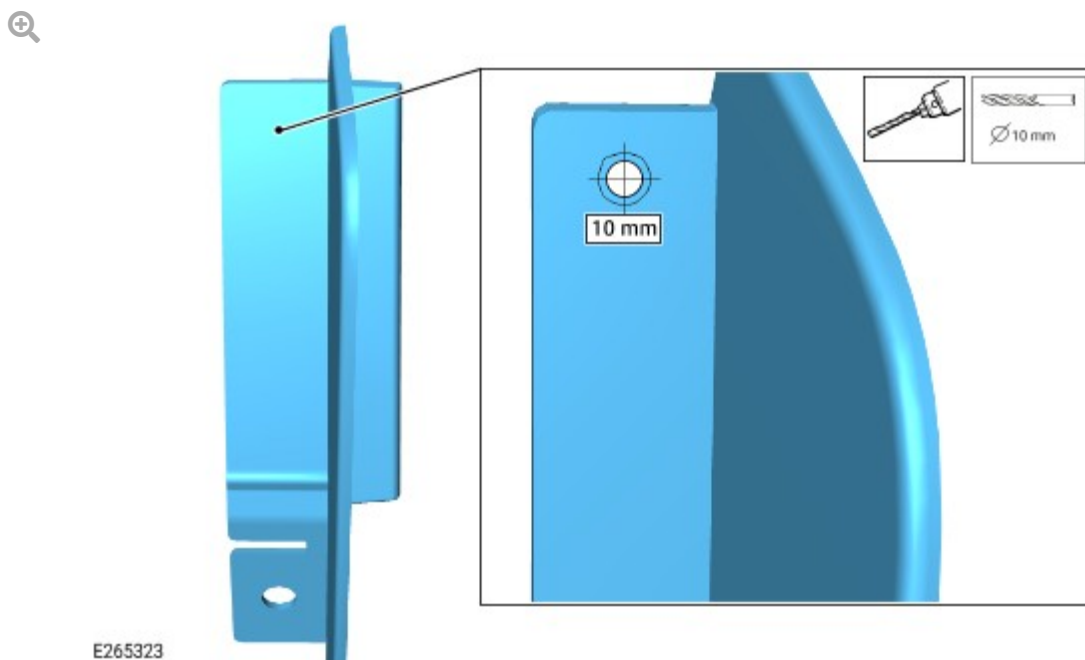

Using a 10 mm drill, increase the size of the new hole in the left air deflector from 6 mm to 10 mm.

7.

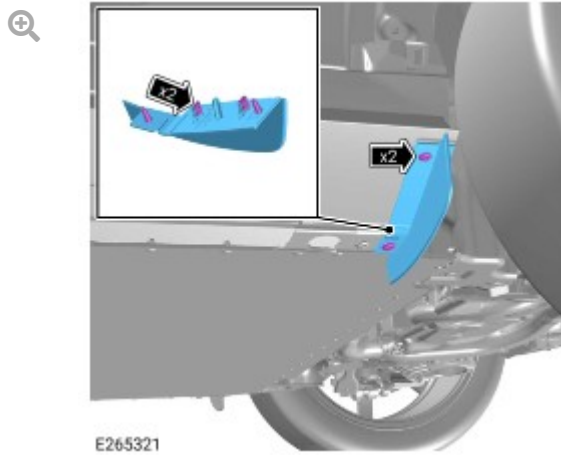

Install the left air deflector.

- Secure the 2 retaining clips.
- Secure the 2 retaining screws.

---

8. Repeat steps 2 to 7 for the right air deflector.

---

9. Lower the vehicle (see TOPIx Workshop Manual section 100-02: Jacking and Lifting - Description and Operation - Jacking and Lifting).