

FLA COE
FLB COE
FLD Conventional
Business Class
FLC 112 Conventional

Century Class Conventional
Argosy
Cargo
Columbia
122SD and Coronado

> Business Class M2
Cascadia
> 108SD/114SD
New Cascadia

**Freightliner
Service Bulletin**

Description of Revisions: *This bulletin replaces the version dated 06/29/2020. Two new illustrations have been added to demonstrate proper application of butterfly tie straps on the transmission.*

General Information

Allison transmission wiring harness chafing causes disruption to gear engagement and fault code generation. To reduce chafing, the wiring is routed using stand off brackets and tie straps to minimize contact with the transmission parts. If chafed wiring is discovered, reference FSB 54-290 for proper repair procedure. This bulletin applies to vehicles equipped with on-board diagnostics (OBDs) manufactured after 2016.

Harness Routing for 1K and 2K Models

The following transmission harness routing instructions are for 1K and 2K models with different fuel tank configurations and equipped with a DD5, DD8, or Cummins 6.7L engine. Refer to [Table 1](#) for parts list for 1K and 2K transmissions only.

Right-Hand (RH) Single Fuel Tank

Mount the bracket (23-09130-017) using the self tapping screw (23-13974-020). Attach the harness to the bracket using the fir tree with a tie strap (23-13482-003). See [Fig. 1](#).

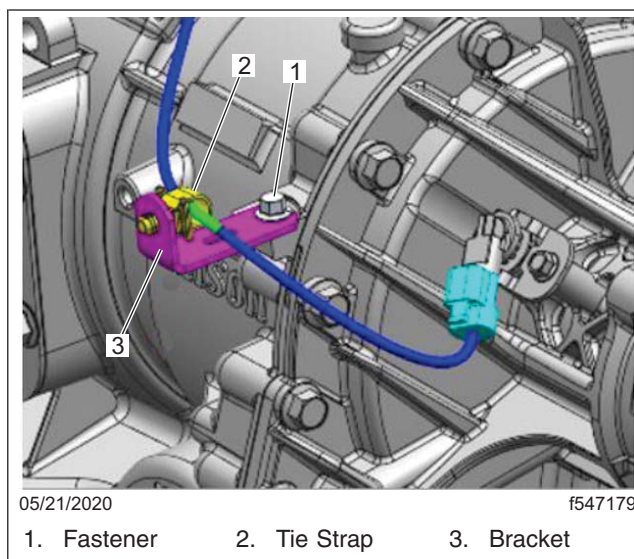

Fig. 1, RH Single Fuel Tank Configuration

Left-Hand (LH) Single Fuel Tank

Mount the bracket (23-09130-017) using the self tapping screw (23-13974-020). Attach the harness to the bracket using the fir tree with a tie strap (23-13482-003). See [Fig. 2](#).

FLA COE
FLB COE
FLD Conventional
Business Class
FLC 112 Conventional

Century Class Conventional
Argosy
Cargo
Columbia
122SD and Coronado

> Business Class M2
Cascadia
> 108SD/114SD
New Cascadia

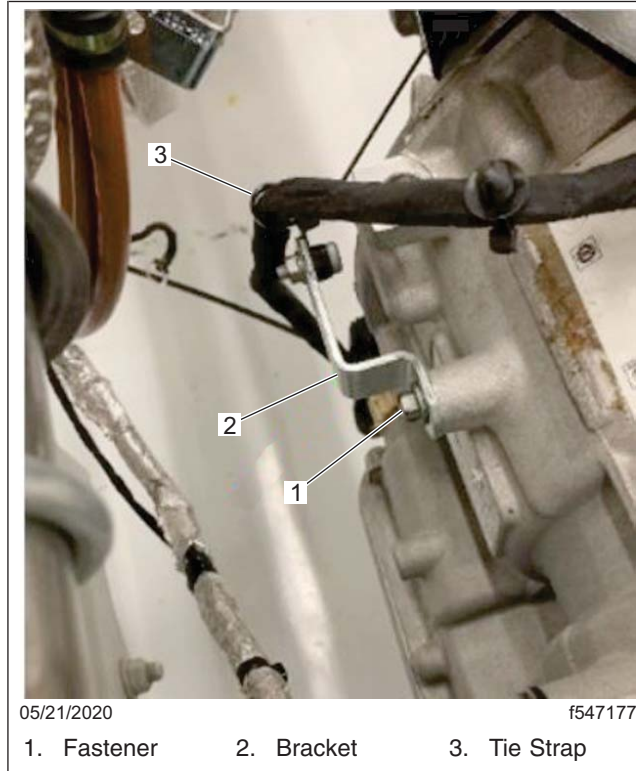

Fig. 2, LH Single Fuel Tank Configuration

Dual Fuel Tanks

Install the fir tree (23-13482-003) below the fuel line bracket (the one used to mount the 'tee valves'). See [Fig. 3](#).

FLA COE
FLB COE
FLD Conventional
Business Class
FLC 112 Conventional

Century Class Conventional
Argosy
Cargo
Columbia
122SD and Coronado

> Business Class M2
Cascadia
> 108SD/114SD
New Cascadia

Freightliner
Service Bulletin

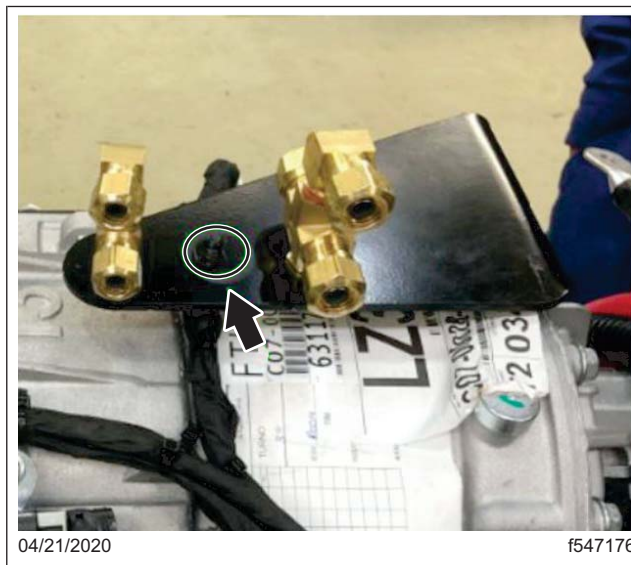

Fig. 3, Dual Fuel Tank Configuration

Any Fuel Tank Configuration

Replace the existing bracket used to support the fuel lines with bracket 06-09782-000. Use the bottom hole with the fir tree tie (23-13482-003) to clip the transmission harness. See [Fig. 4](#).

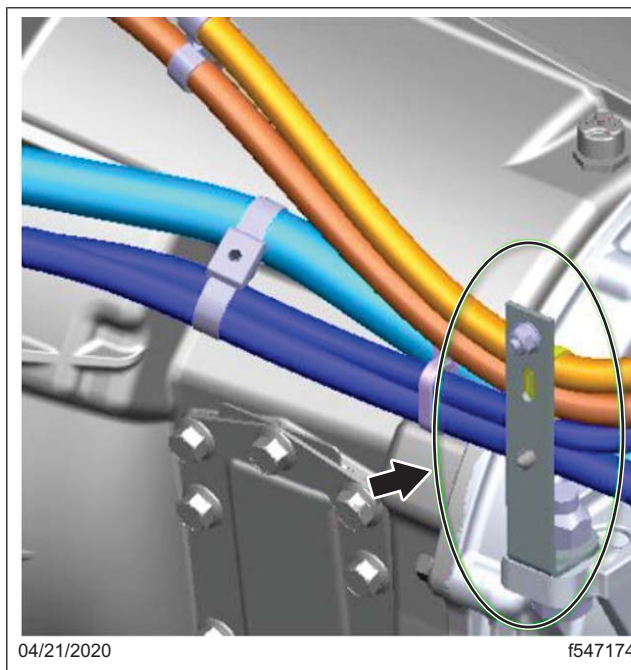

Fig. 4, Any Fuel Tank Configuration

Freightliner Service Bulletin

FLA COE
FLB COE
FLD Conventional
Business Class
FLC 112 Conventional

Century Class Conventional
Argosy
Cargo
Columbia
122SD and Coronado

> Business Class M2
Cascadia
> 108SD/114SD
New Cascadia

Install the bracket (23-13863-003) together with the fir tree (23-13482-004) near the turbine speed sensor to move the transmission harness away from other components. See [Fig. 5](#).

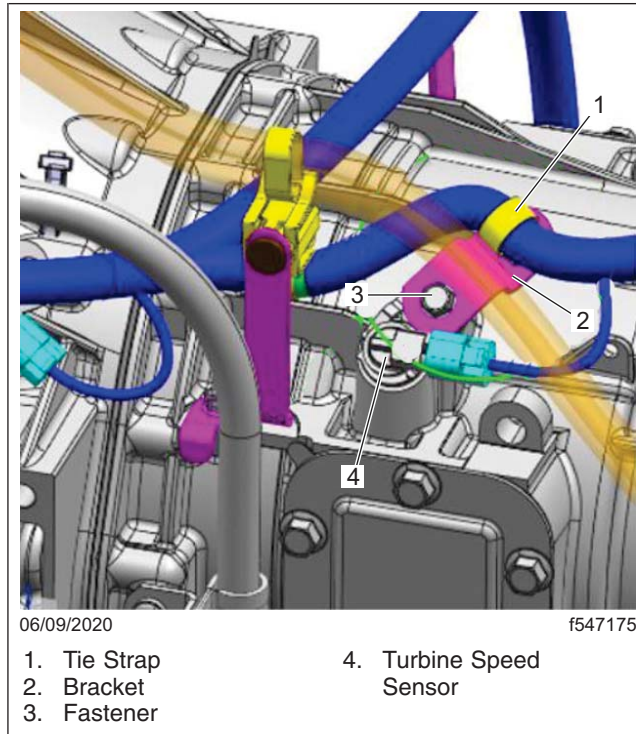

Fig. 5, Any Fuel Tank Configuration near Turbine Speed Sensor

Harness Routing for 3K and 4K Models

Right-Hand (RH) Single Fuel Tank

Route the harness together with the fuel lines on the left side and install the bracket (06-09782-000) with the fir tree (23-13482) on the right side as shown in the [Fig. 4](#).

Right-Hand (RH) Single Fuel Tank

Route the transmission harness together with the fuel lines using butterfly tie straps (TYC DCT110HR). See [Fig. 6](#).

FLA COE
FLB COE
FLD Conventional
Business Class
FLC 112 Conventional

Century Class Conventional
Argosy
Cargo
Columbia
122SD and Coronado

> Business Class M2
Cascadia
> 108SD/114SD
New Cascadia

Freightliner
Service Bulletin

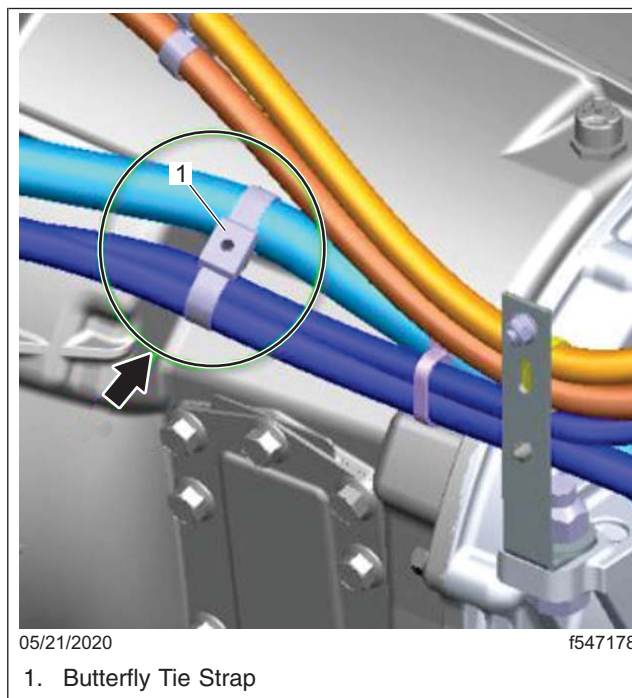

Fig. 6, LH Single Fuel Tank

Dual Fuel Tanks

Route the harness together with the fuel lines and use the fuel line bracket to clip the harness using the fir tree tie (23-13335-002).

For M2 112, 114SD with DD13 and 114SD with X12 engines

1. Use the coolant diesel exhaust fluid (DEF) lines to route the harness with a butterfly tie strap (TYC DCT110HIR) similar to [Fig. 6](#).
2. Install the bracket (23-09130-011), nut (23-13833-108), washer (23-09114-000) and the bolt (23-09440-150) on the right-side of the transmission to route the harness coming down from the coolant DEF lines. Use the fir tree tie strap (23-13482-003) to clip the transmission harness to the bracket. See [Fig. 7](#).

Freightliner Service Bulletin

FLA COE
FLB COE
FLD Conventional
Business Class
FLC 112 Conventional

Century Class Conventional
Argosy
Cargo
Columbia
122SD and Coronado

> Business Class M2
Cascadia
> 108SD/114SD
New Cascadia

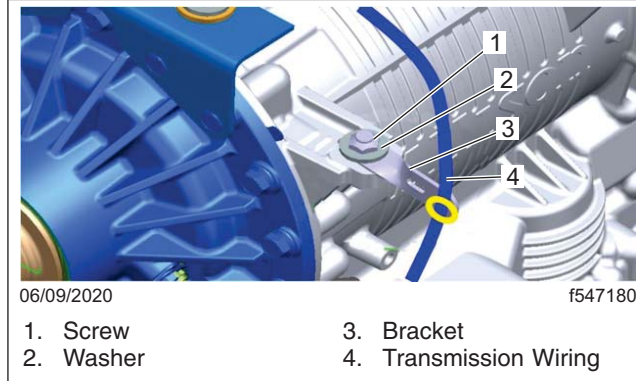

Fig. 7, Transmission Wiring Harness Routing

For All Engines

Install the bracket (23-13863-003) on the rear front cover of the transmission housing to move the harness away from the screws and sharp edges. Use the fir tree tie strap (23-13482-003) to clip the transmission harness to the bracket. See [Fig. 8](#).

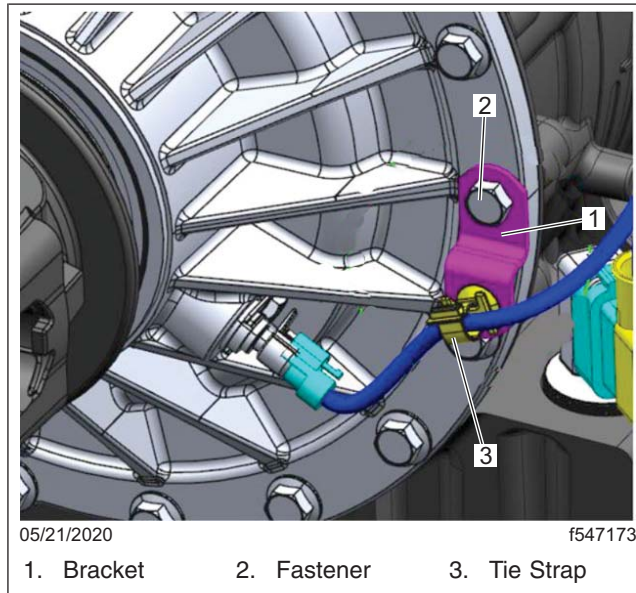

Fig. 8, Rear Front Cover

Instructions for Using Butterfly Tie Straps

NOTE: If the dipstick makes transition from the left side to the right side of the transmission, then it can be used to support the wiring using the following instructions.

1. Use the dipstick to route the harness with butterfly tie strap TYC DCT110HIR. This is applicable for the following models:
 - 3K model with DD8, B6.7 and L9 engines and DC 346-013.

FLA COE
FLB COE
FLD Conventional
Business Class
FLC 112 Conventional

Century Class Conventional
Argosy
Cargo
Columbia
122SD and Coronado

> Business Class M2
Cascadia
> 108SD/114SD
New Cascadia

Freightliner
Service Bulletin

- 3K model with X12 engines.
 - All engines with 4K models.
2. Use the butterfly tie strap TYC DCT110HIR to secure the fill tube to the harness. See [Fig. 9](#).

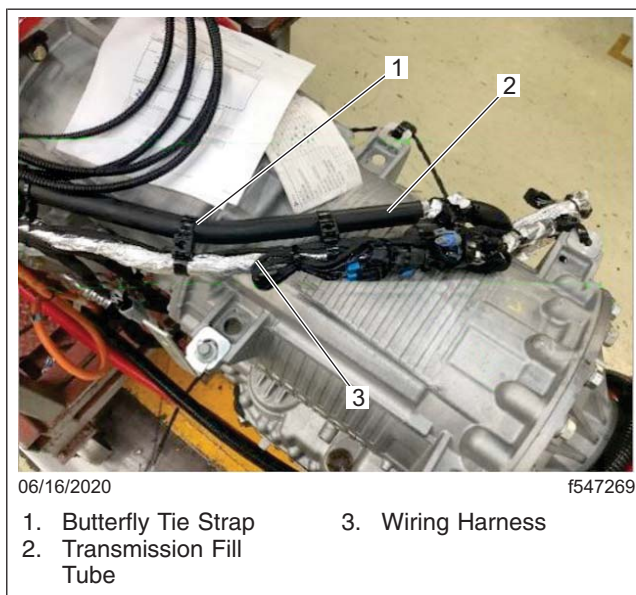

Fig. 9, Securing Fill Tube to the Harness

3. Use the butterfly tie strap TYC DCT110HIR instead of a regular tie strap when clipping the harness to the transmission. See [Fig. 10](#).



Fig. 10, Using a Butterfly Strap to Clip the Harness to the Transmission

Freightliner Service Bulletin

FLA COE
FLB COE
FLD Conventional
Business Class
FLC 112 Conventional

Century Class Conventional
Argosy
Cargo
Columbia
122SD and Coronado

> Business Class M2
Cascadia
> 108SD/114SD
New Cascadia

4. For the 1K2K transmission and DEF wiring located at the front-right side, of the transmission, use a butterfly tie strap TYC DCT110HIR as pictured in [Fig. 11](#).

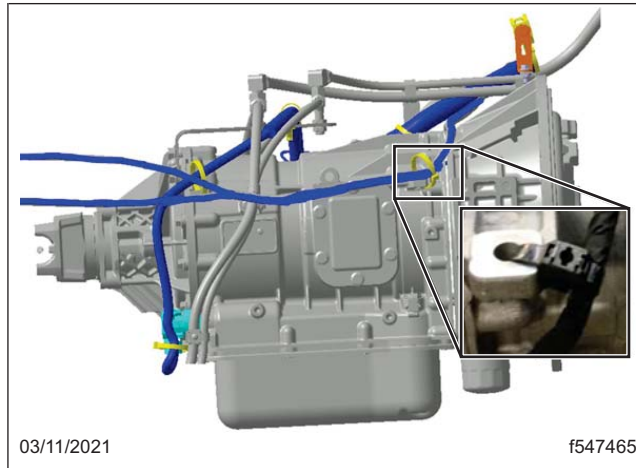

Fig. 11, Using a Butterfly Strap to Clip the Harness to the Transmission

Parts Table for 1K and 2K Models for 106, 108SD with Engines DD5, DD8 & Cummins 6.7

Parts Table			
Fuel Tank Configurations	Part Number	Part Name	Quantity
RH Single Fuel Tank	23-09130-017	BRKTSTANDOFF,.344X.344,ANGLE	1
	23-13974-020	SCREW-TAPPING,HEX FLG,M8X20	1
	23-13482-004	TIE-FIR TREE MT,8.8-9.3MM,SHRT	1
LH Single Fuel Tank	23-09130-021	BRKTSTANDOFF,.531X.281,OFFSET	1
	23-13974-020	SCREW-TAPPING,HEX FLG,M8X20	1
	23-13482-003	TIE-FIR TREE MTD,7.8-8.0MM,FT8	1
Dual Fuel Tank	23-13482-003	TIE-FIR TREE MTD,7.8-8.0MM,FT8	1
Any Fuel Tank Configuration	06-09782-000	BRKT-STDF,T,11 GA CS,25.4	1
	23-13482-003	TIE-FIR TREE MTD,7.8-8.0MM,FT8	1
	23-13863-003	BRKT-STDF,Z,11 GA CS,31.8	1
	23-13482-004	TIE-FIR TREE MT,8.8-9.3MM,SHRT	1

Table 1, Parts Table

FLA COE
 FLB COE
 FLD Conventional
 Business Class
 FLC 112 Conventional

Century Class Conventional
 Argosy
 Cargo
 Columbia
 122SD and Coronado

> Business Class M2
 Cascadia
 > 108SD/114SD
 New Cascadia

**Freightliner
 Service Bulletin**

Warranty

This procedure is warrantable only if the described condition exists and the repair is performed within the applicable base or extended coverage warranty period. If a failure is not found, this procedure is considered preventive and warranty does not apply.

Normal warranty applies. See [Table 2](#) for OWL VMRS codes and labor allowance information. Enter this service bulletin number in the *Service Bulletin #* field.

OWL VMRS Codes and Labor Allowance					
Primary Failed Part	Component Code	Cause Code	SRT Code	Description	Time: Hours
Wiring Harness Allison Transmission	027-038-019	01	345-5041A	Wiring Harness, Allison Transmission, Update routing and brackets	0.4

Table 2, OWL VMRS Codes and Labor Allowance