

DTNA Solutions > Service Solutions > Freightliner
> SS 3073-FTL2021 M2 Rear Suspension Knock

SS 3073-FTL2021 M2 Rear Suspension Knock

Applicable Vehicles

This document applies to Freightliner M2 Business Class used in a "Fire/Emergency" application and equipped with FTL flat leaf spring rear suspensions.

Symptoms

Driver of the vehicle will detect an audible popping or knocking noise from the rear suspension when turning the vehicle.

Issue

The FTL flat leaf spring rear suspension permits the spring pack to shift laterally within the spring hanger brackets. Under heavy cornering load applications, the spring pack can shift laterally and contact the sidewall of the spring hanger bracket. (See Image 1 for reference)

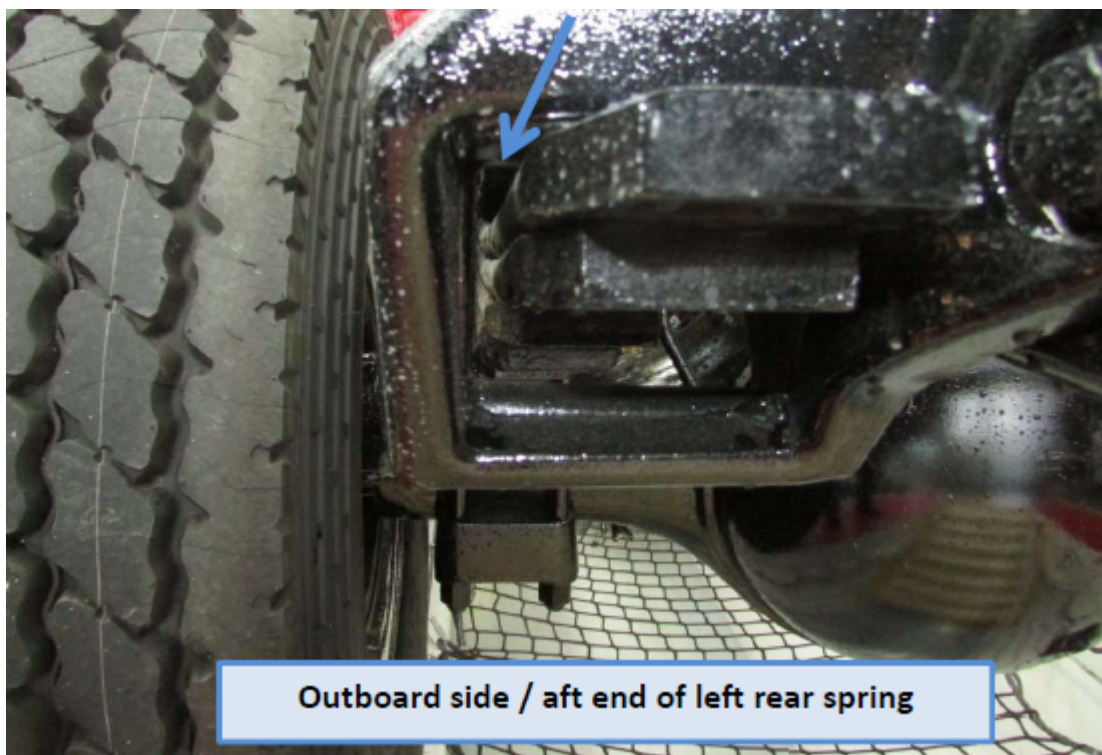

Image 1

Solution

NOTE: To perform this procedure, the suspension hanger brackets need to be removed from the frame rails. Reference Freightliner Business Class Trucks Service Manual Section 32.01 or 32.05 to remove the spring hanger/equalizer brackets and follow all WARNINGS contained therein relating to the removal procedure.

1. Remove spring hanger brackets from the frame rails.
2. If the vehicle has a tandem rear axle, the equalizer brackets need to be removed (see Fig 4).
3. Parts required for the solution are as follows:
 - a. 15-15519-000, QTY 2 for single axle suspensions
 - b. 15-15519-000, QTY 4 for tandem axle suspensions
 - c. 16-21385-000, QTY 2 for all suspensions
4. Install 15-15519-000 spacer plates between the forward spring hanger brackets and the LH and RH frame rails (see Fig 1 and Fig 3).
5. If the suspension includes a helper spring bracket, the 15-15519-000 spacer plate will need to be modified to provide clearance (see Fig 2)
6. Install the 16-21385-000 spacer plates between the rear spring hanger brackets and the LH and RH frame rails (See Fig 1 and Fig 3).
7. For tandem axle suspensions, install the 15-15519-000 spacer plates between the equalizer brackets and the LH and RH frame rails. The 15-15519-000 spacer will need 2 additional 20.6 mm diameter holes drilled for correct fit-up (see Fig 4)
8. After the spacer plates have been installed correctly, ensure the fasteners have been replaced and torqued to specification per the Service/Workshop manual.

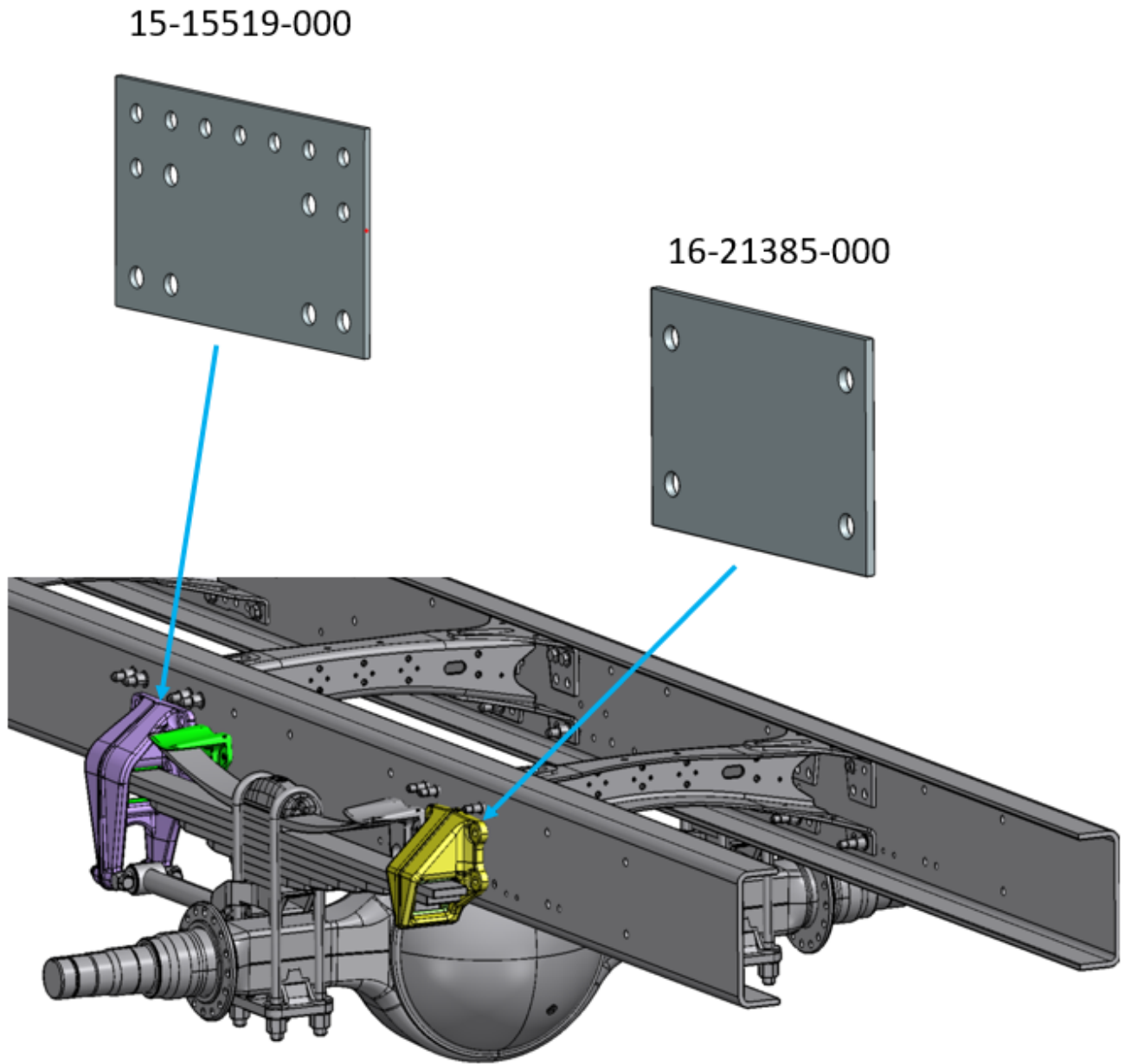

Fig. 1

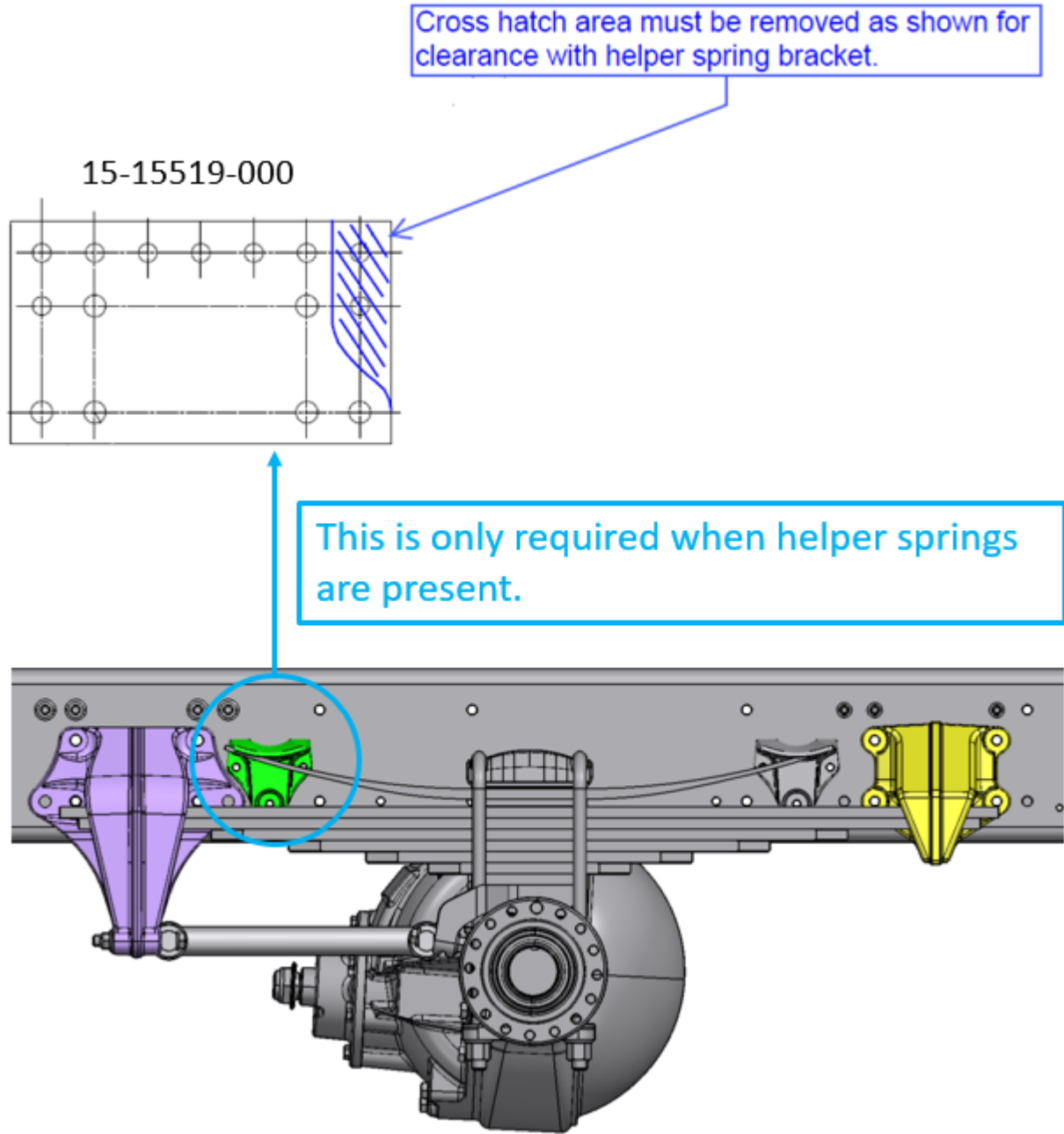

Fig. 2

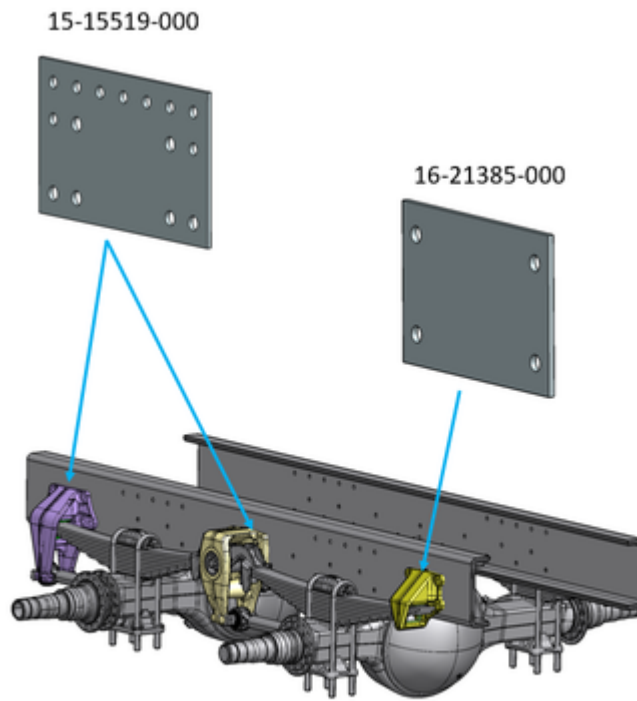

Fig. 3

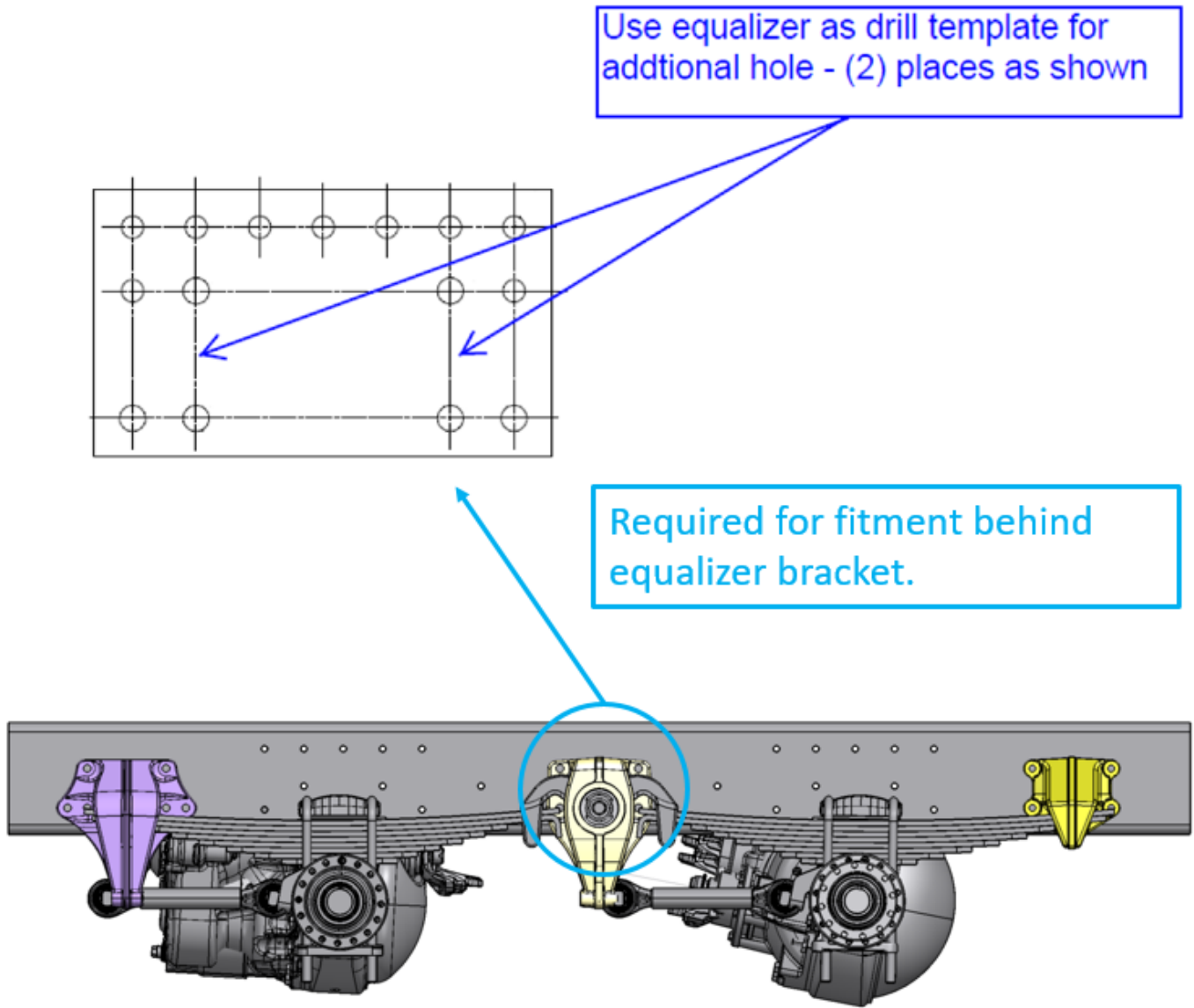

Fig. 4

Labels :

M2

Suspension

Add tags



0 Kudos

Comment

