

Wire Harness, Wire Terminal, and Connector Repair Procedures

Service Category Power Source/Network

Section Power Distribution

Market USA

Toyota Supports
 ASE Certification 

Applicability

YEAR(S)	MODEL(S)	ADDITIONAL INFORMATION
2020 - 2021	Supra	

Introduction

This Service Bulletin provides parts information and repair procedures for wire harnesses, wire terminals, and connectors for 2020 – 2021 model year Supra vehicles.

Warranty Information

OP CODE	DESCRIPTION	TIME	OFP	T1	T2
N/A	Not Applicable to Warranty	–	–	–	–

Wire Harness, Wire Terminal, and Connector Repair Procedures

Table of Contents

- [Parts Information](#)3
- [Required Tools & Equipment](#)15
- [Parts & Tools Verification](#)19
- [Terminal Release Method Examples](#)23
 - [Flat Terminal Systems With One Locking Tab](#)23
 - [Flat Terminal Systems With Two Locking Tabs](#)24
 - [Round Terminal Systems](#)25
 - [Asymmetrical Flat Terminal Systems](#)26
 - [Flat Terminals SLK 2.8 mm Without Secondary Lock](#)27
 - [Flat Terminals SLK 2.8 mm With Secondary Lock](#)27
- [Connector Type Examples](#)28
 - [Type A Connector \(Type 1\)](#)28
 - [Type A Connector \(Type 2\)](#)29
 - [Type B Connector](#)30
 - [Type C Connector](#)31
 - [Type D Connector](#)32
 - [Type E Connector](#)33
 - [Type F Connector](#)34
 - [Type G Connector \(Type 1\)](#)35
 - [Type G Connector \(Type 2\)](#)35
 - [Type H Connector](#)37
 - [Type I Connector](#)38
 - [Type J Connector \(Type 1\)](#)39
 - [Type J Connector \(Type 2\)](#)40
 - [Type J Connector \(Type 3\)](#)42
 - [Type K Connector \(Type 1\)](#)44
 - [Type K Connector \(Type 2\)](#)45
 - [Type L Connector](#)46
 - [Type M Connector](#)48
- [Wire Terminal Replacement](#)49

Wire Harness, Wire Terminal, and Connector Repair Procedures

Parts Information

Table 1.

CONNECTOR NO. (TOYOTA ISTA)	PART NO.		REPAIR WIRE 1		REPAIR WIRE 2		SST NO.	
	TOYOTA	BMW	TOYOTA	BMW	TOYOTA	BMW	PRIMARY LOCK	SECONDARY LOCK
X17*1B	82824-WAA01	61131378109						—
A63*4B	82824-WAA02	61131378460	82998-WAA51	61132466429	—	—	83300495385	83300495395
E3*1B								
X439*1B								
A52*1B	82824-WAA03	61131383502	82998-WAA50	61132466428	82998-WAA09	61130007571		—
A303*1B	82824-WAA04	61132359992	82998-WAA01	61130005197	82998-WAA25	61130006663	83300495394	83300495676
A331*2B								
A331*3B								
A60*1B								
E119*1B								
E119*2B								
E390*1B								
S44*1B								
Y87*1B								
Y88*1B								
A14*1B	82824-WAA05	61132359994						
A88*1B								
E12*1B								
E38*1B								
E39*2B								
E405*1B								

Wire Harness, Wire Terminal, and Connector Repair Procedures

Parts Information (continued)

Table 1. (continued)

CONNECTOR NO. (TOYOTA ISTA)	PART NO.		REPAIR WIRE 1		REPAIR WIRE 2		SST NO.	
	TOYOTA	BMW	TOYOTA	BMW	TOYOTA	BMW	PRIMARY LOCK	SECONDARY LOCK
E80*1B	82824-WAA05	611323599 94	82998-WAA01	611300051 97	82998-WAA25	611300066 63	833004953 94	833004956 76
E82*2B								
S137*1B								
S178*1B								
S179*1B								
S25*1B								
S3*1B								
S30*1B								
S36*1B								
S5*1B								
S52*1B								
S69*1B								
B63*1B	82824-WAA06	611323599 96	82998-WAA08	611300072 57	82998-WAA12	611300569 65	833004953 96	833004953 95
B64*1B								
S142*1B	82824-WAA07	611323599 97					—	—
B13*1B	82824-WAA08	611323599 98	—	—	—	—	833004953 94	833004953 94
B7*1B								
H1*1B								
S17*1B								
B12*1B	82824-WAA09	611323600 43	82998-WAA25	611300066 63			833004956 76	
B207*1B								

Wire Harness, Wire Terminal, and Connector Repair Procedures

Parts Information (continued)

Table 1. (continued)

CONNECTOR NO. (TOYOTA ISTA)	PART NO.		REPAIR WIRE 1		REPAIR WIRE 2		SST NO.	
	TOYOTA	BMW	TOYOTA	BMW	TOYOTA	BMW	PRIMARY LOCK	SECONDARY LOCK
Y73*1B	82824-WAA16	611369255 86	82998-WAA25	611300066 63	82998-WAA26	611300569 62	833004953 96	833004953 95
Y74*1B					82998-WAA38			
A83*1B	82824-WAA17	611369545 18						833004956 76
S180*1B	82824-WAA18	611369545 54	82998-WAA26	611300569 62			833004953 94	833004953 87
E103*2B	82824-WAA19	611369822 58	-	-	-	-		
E122*1B								
M213*1B	82824-WAA20	611369871 06	82998-WAA26	611300569 62	82998-WAA29	611300705 76	833004953 96	833004953 95
M214*1B								
M221*1B								
M222*1B								
M227*1B								
M228*1B								
E204*1B	82824-WAA22	611369921 66	82998-WAA15	611300563 84	82998-WAA40	125200850 56	833004955 78	
E5*1B			82998-WAA28	125200705 73	82998-WAA35	611300850 34		
E57*1B			82998-WAA15	611300563 84	82998-WAA40	125200850 56		
E62*1B			82998-WAA28	125200705 73	82998-WAA35	611300850 34		
E86*1B								
X95*1B	82824-WAA23	611369929 63	82998-WAA46	611300863 69	82998-WAA47	611300863 70	833004953 98	
A279*1B	82824-WAA24	125275052 25	82998-WAA06	125200071 70	82998-WAA48	125224621 72	833004955 78	
A279*1B			82998-WAA54	611324717 90	-	-		
A280*1B			82998-WAA06	125200071 70	82998-WAA48	125224621 72		

Wire Harness, Wire Terminal, and Connector Repair Procedures

Parts Information (continued)

Table 1. (continued)

CONNECTOR NO. (TOYOTA ISTA)	PART NO.		REPAIR WIRE 1		REPAIR WIRE 2		SST NO.	
	TOYOTA	BMW	TOYOTA	BMW	TOYOTA	BMW	PRIMARY LOCK	SECONDARY LOCK
B65*1B	82824- WAA09	611323600 43	82998- WAA25	611300066 63	-	-	833004956 76	833004953 94
B75*3B								
B82*1B								
B85*3B								
B86*1B								
E13*1B								
E350*2B								
E59*1B								
E70*1B								
S31*1B								
S43*1B								
A21*1B	82824- WAA10	611369016 62	82998- WAA26	611300569 62			833004953 94	
A243*1B	82824- WAA11	611369051 68	82998- WAA18	611300569 47	82998- WAA26	611300569 62	833004953 96	833004953 95
A244*1B								
S154*1B	82824- WAA12	611369065 80	82998- WAA29	611300705 76	-	-		833004956 76
A52*4B	82824- WAA13	611369073 85	-	-	-	-	833004953 99	833004953 95
S63*1B	82824- WAA14	611369090 08	82998- WAA26	611300569 62	82998- WAA25	611300066 63	833004953 94	833004956 76
X20*1B								
X501*1S	82824- WAA15	611369136 35	82998- WAA02	611300051 98	82998- WAA04	611300066 64		833004953 95
X501*1S			82998- WAA30	611300705 78	-	-		
S136*1B	82824- WAA16	611369255 86	82998- WAA26	611300569 62	-	-	833004953 96	

Wire Harness, Wire Terminal, and Connector Repair Procedures

Parts Information (continued)

Table 1. (continued)

CONNECTOR NO. (TOYOTA ISTA)	PART NO.		REPAIR WIRE 1		REPAIR WIRE 2		SST NO.	
	TOYOTA	BMW	TOYOTA	BMW	TOYOTA	BMW	PRIMARY LOCK	SECONDARY LOCK
Y53*1B	82824-WAA25	611375433 13	82998-WAA21	125200569 54	-	-	833004956 76	833004953 95
K5*1B			82998-WAA14					
B28*1B			82998-WAA21					
B40*1B								
B45*1B								
B51*1B								
B57*1B								
B80*1B								
Y42*1B	82824-WAA26	125275490 33	82998-WAA14	125200563 74	82998-WAA21	125200569 54	833004953 94	
A416*2B	82824-WAA27	611375702 15	82998-WAA36	125200850 36	82998-WAA37	125200850 37	833004953 33	
A416*2B			82998-WAA23	125200569 58	-	-		
A416*1B	82824-WAA28	125275702 17	82998-WAA24	611300569 59	82998-WAA36	125200850 36		
X148*1B	82824-WAA29	611375903 58			82998-WAA34	611300781 60		
X13*1S	82824-WAA30	611375903 65			82998-WAA45	125200862 69		
X148*1S			82998-WAA34	611300781 60				
X148*1S								
H2*1B	82824-WAA31	125276010 23	82998-WAA55	611324718 39	-	-	833004954 03	
H3*1B								
M94*1B	82824-WAA32	611383645 20	82998-WAA32	611300705 86	82998-WAA10	611300096 33	833004953 98	833004956 76
X258*1B	82824-WAA33	611383646 24	-	-	-	-	833004953 96	833004953 96
B465*1B			82998-WAA11	611300051 99				

Wire Harness, Wire Terminal, and Connector Repair Procedures

Parts Information (continued)

Table 1. (continued)

CONNECTOR NO. (TOYOTA ISTA)	PART NO.		REPAIR WIRE 1		REPAIR WIRE 2		SST NO.			
	TOYOTA	BMW	TOYOTA	BMW	TOYOTA	BMW	PRIMARY LOCK	SECONDARY LOCK		
X149*1B	82824-WAA33	611383646 24	82998-WAA35	611300850 34	-	-	833004953 96	833004953 96		
X148*2S	82824-WAA34	611383646 25	82998-WAA43	611300862 67			833004953 94	833004956 76		
X20*1S	82824-WAA36	611383646 75	82998-WAA27	611300705 62	82998-WAA30	611300705 78	833004953 96	833004953 95		
X848*1B	82824-WAA37	611383653 56	82998-WAA05	611300066 65	82998-WAA11	611300051 99	833004953 94	833004956 76		
X848*1B			82998-WAA15	611300563 84	-	-				
X849*1B			82998-WAA05	611300066 65	82998-WAA11	611300051 99				
X849*1B			82998-WAA15	611300563 84	-	-				
B17*1B	82824-WAA38	611383733 32	82998-WAA07	611300072 56	82998-WAA31	611300705 81	833004953 96			
B156*1B	82824-WAA39	611383770 72	82998-WAA25	611300066 63	82998-WAA01	611300051 97	833004956 76	833004953 95		
B156*1B					-	-				
B2*1B										
B3*1B										
E131*2B										
E22*1B										
E245*1B					82998-WAA26	611300569 62			82998-WAA25	611300066 63
E34*1B										
E84*1B										
S165*1B										
S94*1B										
X1554*2B					82998-WAA25	611300066 63			-	-
X1559*1B					82998-WAA26	611300569 62			82998-WAA25	611300066 63

Wire Harness, Wire Terminal, and Connector Repair Procedures

Parts Information (continued)

Table 1. (continued)

CONNECTOR NO. (TOYOTA ISTA)	PART NO.		REPAIR WIRE 1		REPAIR WIRE 2		SST NO.	
	TOYOTA	BMW	TOYOTA	BMW	TOYOTA	BMW	PRIMARY LOCK	SECONDARY LOCK
Y30*1B	82824-WAA40	611383771 52	82998-WAA44	611300862 68			833004953 94	
Y31*1B								
Y32*1B								
Y9*1B								
A67*1B	82824-WAA41	611383833 00	82998-WAA35	611300850 34	-	-	833004953 95	833004956 76
B11*1B								
B39*1B			82998-WAA11	611300051 99				
B81*1B								
X148*2B			82998-WAA35	611300850 34				
A42*2B	82824-WAA42	611383872 14	-	-			833004953 83	
A52*2B								
E131*1B	82824-WAA43	611391302 46	82998-WAA26	611300569 62			833004953 94	833004953 95
S153*3B	82824-WAA44	611391325 77						
S45*1B		611391325 77	82998-WAA25	611300066 63			82998-WAA26	
A245*8B	82824-WAA45	611391429 00	82998-WAA26	611300569 62			-	
M12*1B	82824-WAA46	611391442 34	82998-WAA48	125224621 72	82998-WAA54	611324717 90	833004953 33	833004953 95
A42*1B	82824-WAA47	611391924 78	82998-WAA13	611300563 70	82998-WAA17	611300569 46	833004956 76	
A42*1B			82998-WAA26	611300569 62	82998-WAA29	611300705 76		
K5*2B	82824-WAA48	611392079 14	82998-WAA41	611300850 60	-	-	833004953 99	-
X28*1B_2	82824-WAA49	611392210 20	82998-WAA27	611300705 62			833004953 94	833004953 95
X5*1S_2								

Wire Harness, Wire Terminal, and Connector Repair Procedures

Parts Information (continued)

Table 1. (continued)

CONNECTOR NO. (TOYOTA ISTA)	PART NO.		REPAIR WIRE 1		REPAIR WIRE 2		SST NO.			
	TOYOTA	BMW	TOYOTA	BMW	TOYOTA	BMW	PRIMARY LOCK	SECONDARY LOCK		
X28*1B	82824-WAA50	611392210 22	82998-WAA25	611300066 63	82998-WAA26	611300569 62	833004953 96	833004953 95		
X28*1B			82998-WAA29	611300705 76	-	-				
X5*1S			82998-WAA25	611300066 63	82998-WAA26	611300569 62				
X5*1S			82998-WAA29	611300705 76						
B18*1B	82824-WAA51	611392306 59	82998-WAA39	611300850 48			833004953 98			
M219*1B	82824-WAA52	611392384 90	82998-WAA25	611300066 63			833004953 94	833004956 76		
M220*1B										
S154*2B	82824-WAA53	611392450 24	82998-WAA26	611300569 62						
S157*1B										
A24*1B	82824-WAA54	611392819 35	82998-WAA16	611300569 43			833004953 95	833004953 95		
E363*1B	82824-WAA55	611392881 51								
A331*1B	82824-WAA56	611392996 10							833004956 76	833004953 95
A46*1B	82824-WAA57	611393186 33							82998-WAA22	125200569 57
X6*1B	82824-WAA58	611393352 61	82998-WAA19	611300569 50	82998-WAA20	611300569 51	833004953 33	833004953 95		
A98*1B	82824-WAA59	611393492 50	82998-WAA49	125224621 73	82998-WAA52	125224665 84	833004954 03			
A98*1B			82998-WAA53	125224665 85						
A56*1B	82824-WAA60	611393531 05					833004956 76	833004956 76		
A376*1B										
A42*3B	82824-WAA61	611393531 06	82998-WAA16	611300569 43			833004953 94	833004953 95		
A376*2B										
A376*3B										

Wire Harness, Wire Terminal, and Connector Repair Procedures

Parts Information (continued)

Table 1. (continued)

CONNECTOR NO. (TOYOTA ISTA)	PART NO.		REPAIR WIRE 1		REPAIR WIRE 2		SST NO.	
	TOYOTA	BMW	TOYOTA	BMW	TOYOTA	BMW	PRIMARY LOCK	SECONDARY LOCK
X1872*1S	82824-WAA62	611393577 94	82998-WAA27	611300705 62	82998-WAA30	611300705 78	833004953 94	833004953 96
B56*1B	90118-WA607	611323599 99	-	-	-	-	833004956 76	833004953 95
E23*1B								
E33*1B								
E35*1B								
E83*1B								
M72*1B								
S1*1B								
X21*1B								
X217*1B								
X26*1B								
X32*1B								
X33*1B								
X34*1B								
X35*1B								
Y46*1B								
Y47*1B								

Wire Harness, Wire Terminal, and Connector Repair Procedures

Parts Information (continued)

Table 2.

TOYOTA		BMW	
CONNECTOR PART NO.	PART NAME	CONNECTOR PART NO.	PART NAME
82824-WAA01	Connector, Wiring Harness	61131378109	-
82824-WAA02			
82824-WAA03			
82824-WAA04			
82824-WAA05			
82824-WAA06			
82824-WAA07			
82824-WAA08			
82824-WAA09			
82824-WAA10			
82824-WAA11			
82824-WAA12			
82824-WAA13			
82824-WAA14			
82824-WAA15			
82824-WAA16			
82824-WAA17			
82824-WAA18			
82824-WAA19			
82824-WAA20			
82824-WAA22			
82824-WAA45			
82824-WAA46			
82824-WAA47			
82824-WAA48			
82824-WAA49			
82824-WAA50			
82824-WAA51			
82824-WAA52			
82824-WAA53			
82824-WAA54			
82824-WAA55			
82824-WAA56			
82824-WAA57			
82824-WAA58			

Wire Harness, Wire Terminal, and Connector Repair Procedures

Parts Information (continued)

Table 2. (continued)

TOYOTA		BMW	
CONNECTOR PART NO.	PART NAME	CONNECTOR PART NO.	PART NAME
82824-WAA59	Connector, Wiring Harness	61139349250	-
82824-WAA60		61139353105	
82824-WAA61		61139353106	
82824-WAA62		61139357794	
82998-WAA01	Terminal, Repair W/Wire	61130005197	
82998-WAA02		61130005198	
82998-WAA03		61130006663	
82824-WAA23	Connector, Wiring Harness	61136992963	
82824-WAA24		12527505225	
82824-WAA25		61137543313	
82824-WAA26		12527549033	
82824-WAA27		61137570215	
82824-WAA28		12527570217	
82824-WAA29		61137590358	
82824-WAA30		61137590365	
82824-WAA31		12527601023	
82824-WAA32		61138364520	
82824-WAA33		61138364624	
82824-WAA34		61138364625	
82824-WAA36		61138364675	
82824-WAA37		61138365356	
82824-WAA38		61138373332	
82824-WAA39		61138377072	
82824-WAA40		61138377152	
82824-WAA41		61138383300	
82824-WAA42		61138387214	
82824-WAA43		61139130246	
82824-WAA44	61139132577		
82998-WAA25	Terminal, Repair W/Wire	61130006663	
82998-WAA26		61130056962	
82998-WAA27		61130070562	
82998-WAA29		61130070576	
82998-WAA30		61130070578	
82998-WAA31		61130070581	
82998-WAA32		61130070586	

Wire Harness, Wire Terminal, and Connector Repair Procedures

Parts Information (continued)

Table 2. (continued)

TOYOTA		BMW	
CONNECTOR PART NO.	PART NAME	CONNECTOR PART NO.	PART NAME
82998-WAA33	Terminal, Repair W/Wire	61130070645	
82998-WAA34		61130078160	
82998-WAA35		61130085034	
82998-WAA36		12520085036	
82998-WAA37		12520085037	
82998-WAA38		61130085042	
82998-WAA39		61130085048	
82998-WAA40		12520085056	
82998-WAA41		61130085060	
82998-WAA42		12520086266	
82998-WAA43		61130086267	
82998-WAA44		61130086268	
82998-WAA45		12520086269	
82998-WAA46		61130086369	
82998-WAA47		61130086370	
82998-WAA48		12522462172	
82998-WAA49		12522462173	
82998-WAA50		61132466428	
82998-WAA51		61132466429	
82998-WAA52		12522466584	
82998-WAA53	12522466585		
82998-WAA54	61132471790		
82998-WAA55	61132471839		
90118-WA607	Connector, Wiring Harness	61132359999	
90118-WA702	Covering Cap	61136905200	
90118-WA703	Connector, Wiring Harness	61136913644	
90118-WA704		61136931871	
90118-WA705	Covering Cap	61136954568	
90118-WA706		61138364652	
90118-WA707	Universal Cover Cap, Uncoded	61138364662	
90118-WA708		61138364810	
90118-WA709	Covering Cap	61138364862	
90118-WA710	Connector, Wiring Harness	61138384666	
90118-WA711	Covering Cap	61138387204	
90118-WA712		61139142999	

Wire Harness, Wire Terminal, and Connector Repair Procedures


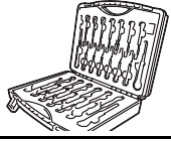
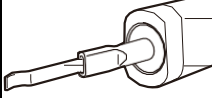
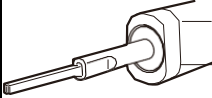
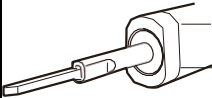
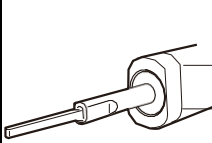
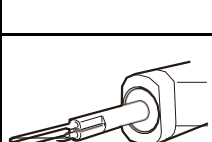
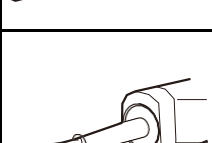
Parts Information (continued)

Table 2. (continued)

TOYOTA		BMW	
CONNECTOR PART NO.	PART NAME	CONNECTOR PART NO.	PART NAME
90118-WA713	Covering Cap	61139143007	-
90118-WA714		61139328853	
90118-WA715		61139345336	
90118-WA716		61139357791	

Required Tools & Equipment

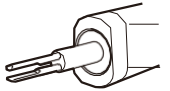
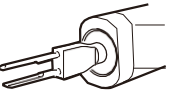
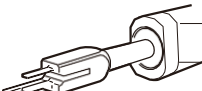
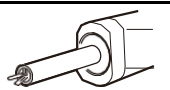
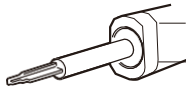
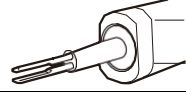
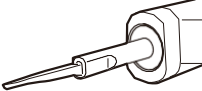
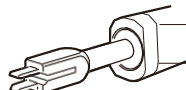




Table 3.

IMAGE EXAMPLE	PART NUMBER		PART NAME	NOTES
	TOYOTA	BMW (BMW OLD)		
	09903-WA010	83300495382 (610300)	Release Tool Set	Complete Set (Contains 09903-Wa240 – 09903-Wa230)
	09903-WA240	83300495407 (610329)	Case	Case W/Foam Material Insert (Tools Not Included)
	09903-WA190	83300495406 (610324)	Release Tool	For Secondary Locks
	09903-WA090	83300495394 (610312)		For Flat Spring Wire Terminals W/Retaining Lug (1.6 mm)
	09903-WA100	83300495395 (610313)		For Flat Spring Wire Terminals W/Retaining Tab (1.9 mm)
	09903-WA110	83300495396 (610314)		For Flat Spring Wire Terminals W/Retaining Tab (2.7 mm)
	09903-WA120	83300495397 (610315)		For Flat Spring Wire Terminals W/Double Retaining Tab (Micro-timer 2)
	09903-WA130	83300495398 (610316)		For Flat Spring Wire Terminals W/Double Retaining Tab (SPT 4.8) (JPT2.8)

Wire Harness, Wire Terminal, and Connector Repair Procedures

Required Tools & Equipment (continued)

Table 3. (continued)

IMAGE EXAMPLE	PART NUMBER		PART NAME	NOTES AND PURPOSE
	TOYOTA	BMW (BMW OLD)		
	09903-WA140	83300495399 (6103170)	Release Tool	For LSK 8 Wire Terminals
	09903-WA150	83300495400 (610318)		For Maxi Power Timer 9.5 Wire Terminals
	09903-WA160	83300495403 (610321)		For Sensor Laminated Wire Terminals W/Release Device (SLK 2.8)
	09903-WA170	83300495404 (610322)		For Mini Laminated Wire Terminals (MLK 1.2 mm)
	09903-WA180	83300495405 (610323)		For Flat Spring Wire Terminals W/Retaining Tab (MQS)
	09903-WA200	83300495578 (610325)		For JPT Wire Terminals
	09903-WA210	83300495676 (610326)		For MQS Wire Terminals
	09903-WA250	83300495680 (610331)		For SLK 5.8 Wire Terminals
	09903-WA260	83300496332 (610332)		For Unlocking MQS (0.64 mm) Wire Terminals
	09903-WA270	83300496333 (610333)		For Unlocking MCON (2.8 mm) Wire Terminals
	09903-WA040	83300495383 (610301)		For Round Wire Terminals (Diameter 1.5 mm)
	09903-WA050	83300495385 (610303)		For Round Wire Terminals (Diameter 2.5 mm)

Wire Harness, Wire Terminal, and Connector Repair Procedures

Required Tools & Equipment (continued)

Table 3. (continued)

IMAGE EXAMPLE	PART NUMBER		PART NAME	NOTES AND PURPOSE
	TOYOTA	BMW (BMW OLD)		
	09903-WA060	83300495387 (610305)	Release Tool	For Round Wire Terminals (Diameter 3.5 mm)
	09903-WA070	83300495389 (610307)		For Socket-end Round Wire Terminals (Diameter 1.5 mm)
	09903-WA080	83300495391 (610309)		For Pin-end Round Wire Terminals (Diameter 1.5 mm)
	09903-WA220	83300495677 (610327)	Insertion Aid	For Inserting Wire Terminals (0.64 mm – 1.2 mm) In Housing
	09903-WA230	83300495678 (610328)		For Inserting Wire Terminals (2.8 mm – 4.8 mm) In Housing
	09929-00020	-	Crimping Tool S*	To Crimp Sleeves Sizes: SS, S, M
	09042-2C100		Crimping Tool*	To Crimp Sleeves Sleeve Sizes: S, M, L
			Wire Cutters	To Cut Wires
			Caliper	To Measure Wire Diameter and Wire Strand
			Dryer or Heat Gun	To Heat Shrink Sleeves (1000W or More, Thermal Fuse With 190°C or More)
			Wood Plate	To Shield Heat (Size Reference: 300 mm X 100 mm X 10 mm)

*Essential SST.

Wire Harness, Wire Terminal, and Connector Repair Procedures

Required Tools & Equipment (continued)

SPECIAL SERVICE TOOLS (SST)	PART NUMBER	QTY
Releasing Tool Set	09903-WA010	1
Supra Diagnostic Cable*	01018-00118	1
DCA-8000 Battery Diagnostic Tool*	DCA-8000P T	1

*Essential SST.

NOTE

- The release tool set is available to dealers as part of the Toyota Loan Tool Program (TLTP). A loan tool order will need be placed to receive these SSTs. Please refer to the Loan Tool Program User's Guide located in the [Supra Service Resources](#) page in TIS for step by step instructions on placing a loan tool order. Select the repair procedure *Wire Harness Repair – Terminal Tools* when prompted to select a repair procedure.
- Supra Diagnostic Software Toyota ISTA version 4.25.20.21842 or later is required. ISTA software is available for download at *TIS – Diagnostics – Scantool*.
- Additional Techstream ADVi units may be ordered through the Techstream Order Portal at *TIS – Diagnostics – Scantool*.
- If additional support is needed to place a loan tool order, please contact Bosch by sending an email to ToyotaLoanTools@service-solutions.com or by calling 1-800-933-8335.

REQUIRED EQUIPMENT	SUPPLIER	PART NUMBER	QTY
Techstream ADVi*	ADE	TSADVUNIT	1
Techstream 2.0		TS2UNIT	
Techstream Lite		TSLITEPDLR01	
Techstream Lite (Green Cable)		TSLP2DLR01	

*Essential SST.

NOTE

- Only ONE of the Techstream units listed above is required.
- Software version 15.30.027 or later is required.
- Additional Techstream units may be ordered by calling Approved Dealer Equipment (ADE) at 1-800-368-6787.

Wire Harness, Wire Terminal, and Connector Repair Procedures

Parts & Tools Verification

1. Verify the connector number by using the Electrical Wiring Diagram (EWD) within the Toyota Integrated Service Technical Application (ISTA). If the connector type cannot be verified by using Toyota ISTA, search within this Service Bulletin for the part number printed on the connector.

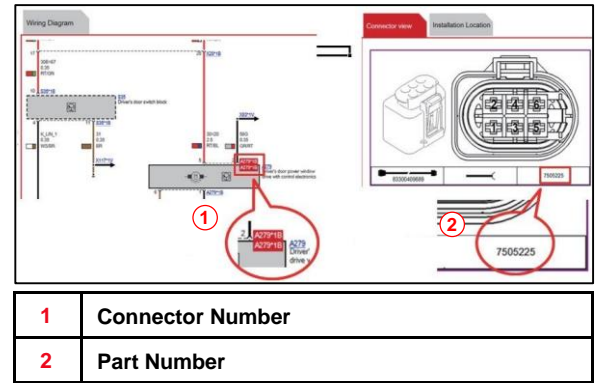
- A. Verify the connector number by using the EWD within the Toyota ISTA.

- (1) Search for the corresponding wiring diagram by using Toyota ISTA.
- (2) The connector number can be found in the wiring diagram as shown. Search for the connector number within this Service Bulletin.

HINT

The search function can be used by pressing Ctrl+F on the keyboard.

Figure 1.



- B. Was the connector number verified using Toyota ISTA?

- **YES** — Go to step 2.
- **NO** — Continue to substep C.

- C. Search for the part number by using Toyota ISTA.

- (1) Click on the wiring diagram connector number.
- (2) The connector view tab is displayed.
- (3) The part number is displayed in the lower right-hand side of the connector diagram. Search for the part number within this Service Bulletin.

HINT

- The search function can be used by pressing Ctrl+F on the keyboard.
- There are occasions in which the part number displayed in the lower right and the supplied part number do NOT match.

- D. Was the connector number verified using Toyota ISTA?

- **YES** — Go to step 2.
- **NO** — Continue to substep E.

Wire Harness, Wire Terminal, and Connector Repair Procedures

Parts & Tools Verification (continued)

- E. Verify the connector number by using the part number printed on the connector.

NOTE

Part numbers are NOT printed on ALL the connectors.

HINT

The search function can be used by pressing Ctrl+F on the keyboard.

- F. Was the connector type verified using the part number printed on the connector?
- **YES** — Go to step 2.
 - **NO** — The connector is NOT serviceable. The wire harness MUST be replaced. Continue diagnosis using the applicable Repair Manual.

Figure 2.



2. Verify the wire harness part number by using the connector part number. Search for the repair wire harness that corresponds to the verified connector.

HINT

The search function can be used by pressing Ctrl+F on the keyboard.

Wire Harness, Wire Terminal, and Connector Repair Procedures

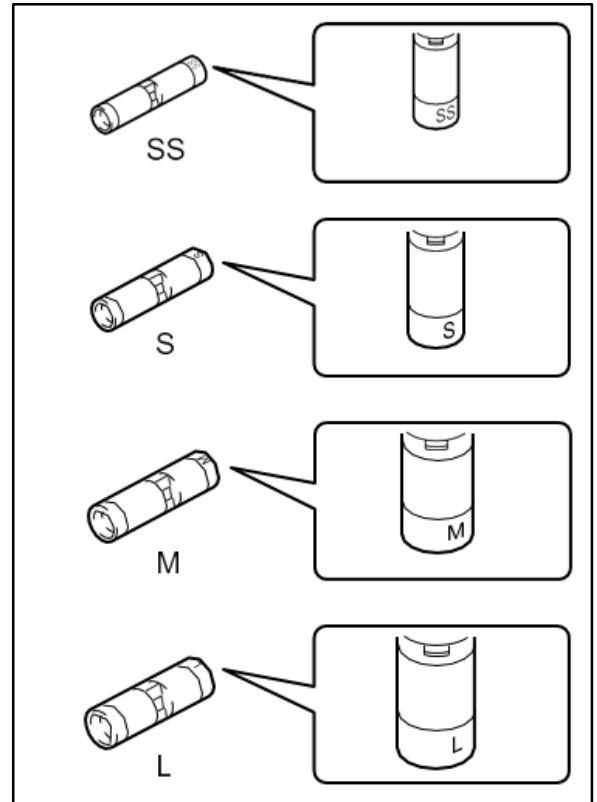
Parts & Tools Verification (continued)

- Verify the sleeve type.
Select the appropriate sleeve by referring to the table shown.

Table 4. Sleeve Size

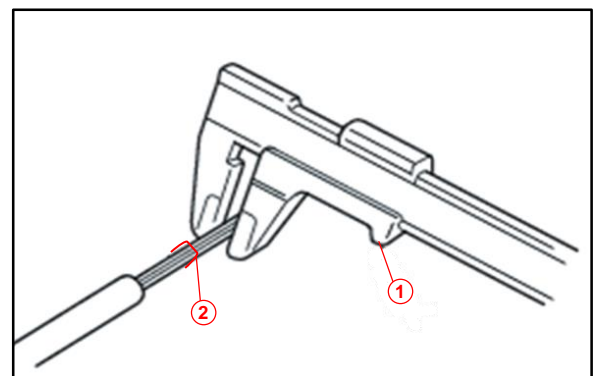
NOMINAL WIRE SIZE (MM2)	SLEEVE SIZE (COLOR)
0.5	SS (Silver)
0.75 – 1.0	S (Silver)
1.25 – 2.5	M (Silver)
3.0 – 5.0	L (Silver)

Figure 3.



- Verify the nominal wire size.
Use the following formula:
Nominal size = 3.14 x (diameter of wire lead)²/4.

Figure 4.



1	Calipers
2	Wire Lead Diameter

Wire Harness, Wire Terminal, and Connector Repair Procedures

Parts & Tools Verification (continued)

5. Use Table 3 in the [Required Tools and Equipment](#) section to verify the release tool type.

HINT

Manufactured by AMP – The following wire terminal types without strand sealing can be fitted in the connectors:

- MQS (Micro Quadlock System).
- MPQ, width 2.8 mm (Micro Power Quadlock).
- MPQ, width 5.2 mm (Micro Power Quadlock).

Manufactured by Siemens – The following wire terminal types without strand sealing can be fitted in the connectors:

- Elo (electrical contact).
- Elo Power 2.8 mm width (electrical wire terminal for heavy loads).
- Elo Power 5.2 mm width (electrical wire terminal for heavy loads).

6. Once ALL necessary parts and tools have been verified, proceed to complete the repair. See a few examples in the [Terminal Release Method Examples](#) section.

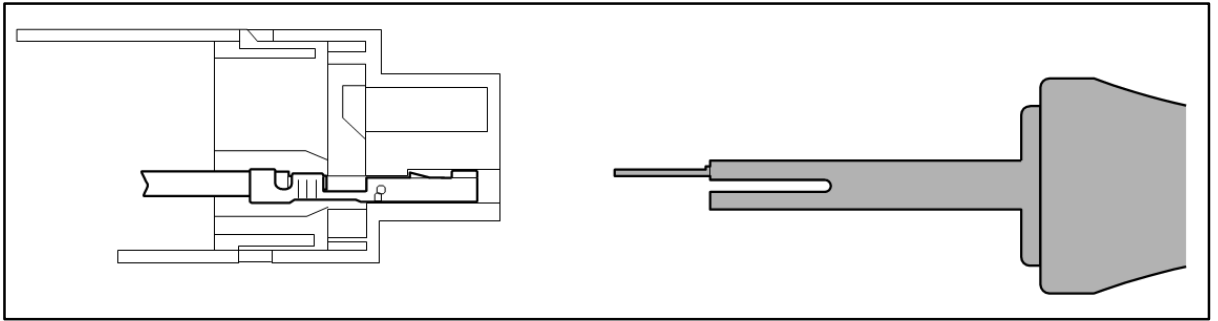
Wire Harness, Wire Terminal, and Connector Repair Procedures

Terminal Release Method Examples

Flat Terminal Systems With One Locking Tab

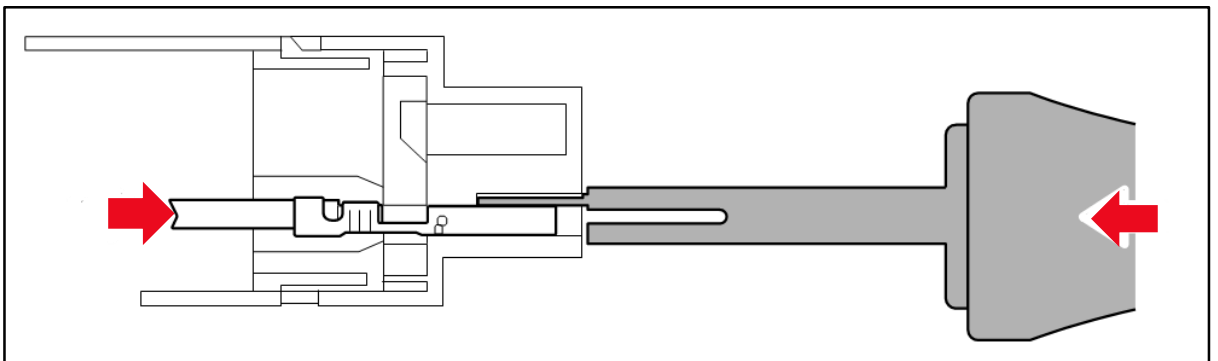
1. Remove the spacers or unlock the secondary locks using the appropriate tool if necessary.
2. Insert the tool into the locking lance to remove the primary lock.

Figure 5.



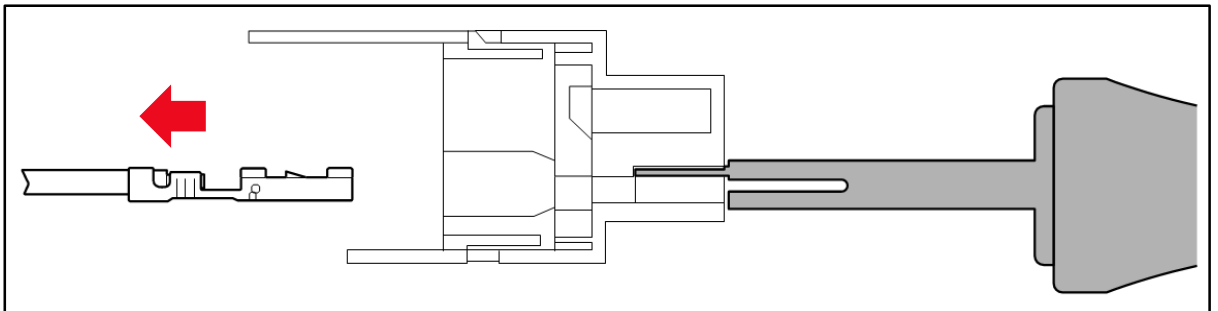
3. Push the wire terminal simultaneously into the locking lance.

Figure 6.



4. Pull the wire terminal out of the connector.

Figure 7.



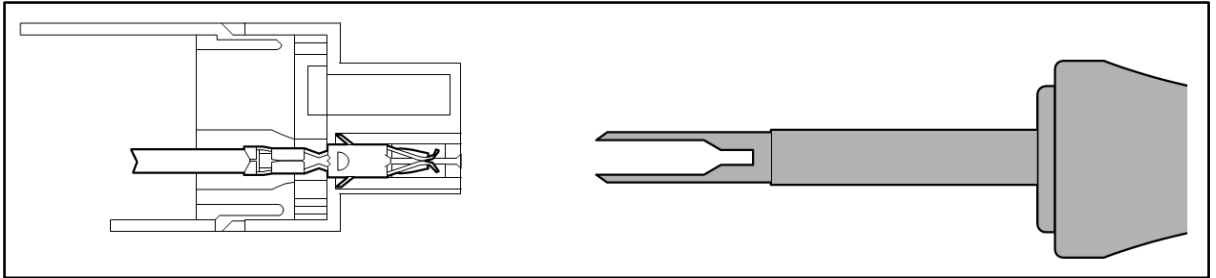
Wire Harness, Wire Terminal, and Connector Repair Procedures

Terminal Release Method Examples (continued)

Flat Terminal Systems With Two Locking Tabs

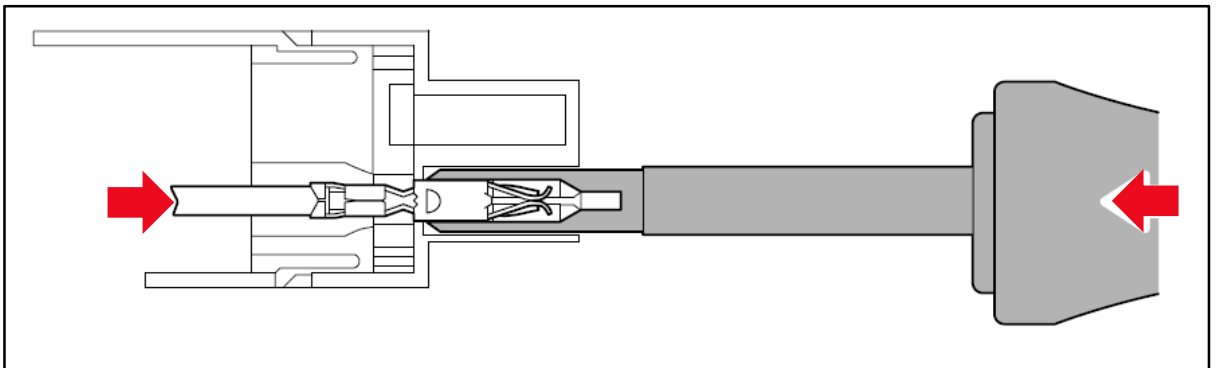
1. Remove the spacers or unlock the secondary locks using the appropriate tool if necessary.
2. Insert the tool into the locking lance to remove the primary lock.

Figure 8.



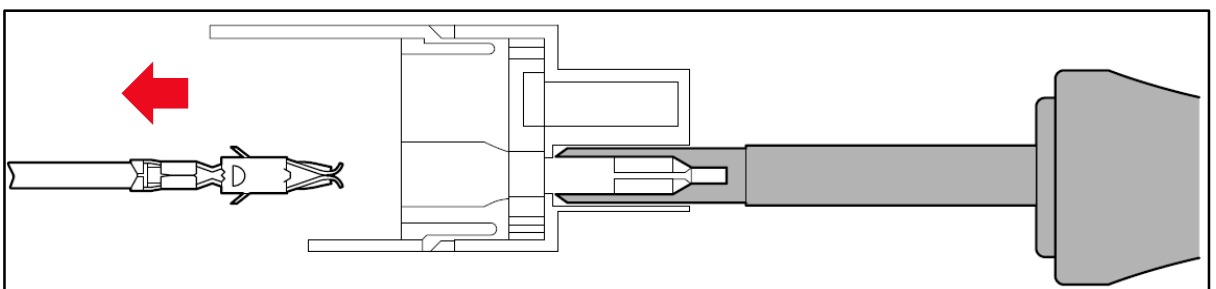
3. Grasp the lead and push the wire terminal in order to release the connector shoulder locking lance.

Figure 9.



4. Pull the wire terminal out of the connector.

Figure 10.



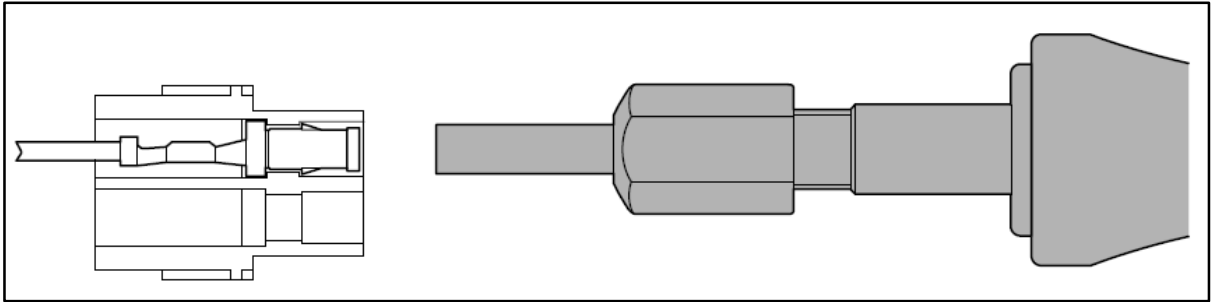
Wire Harness, Wire Terminal, and Connector Repair Procedures

Terminal Release Method Examples (continued)

Round Terminal Systems

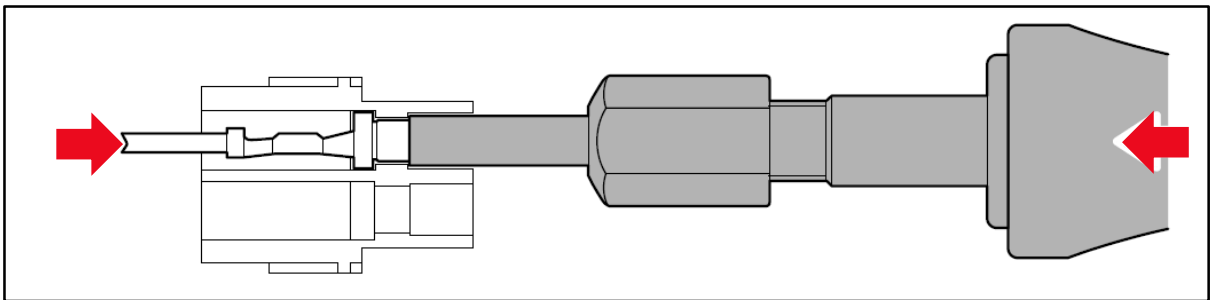
1. Remove the spacers or unlock the secondary locks using the appropriate tool if necessary.
2. Insert the tool into the locking lance to remove the primary lock.

Figure 11.



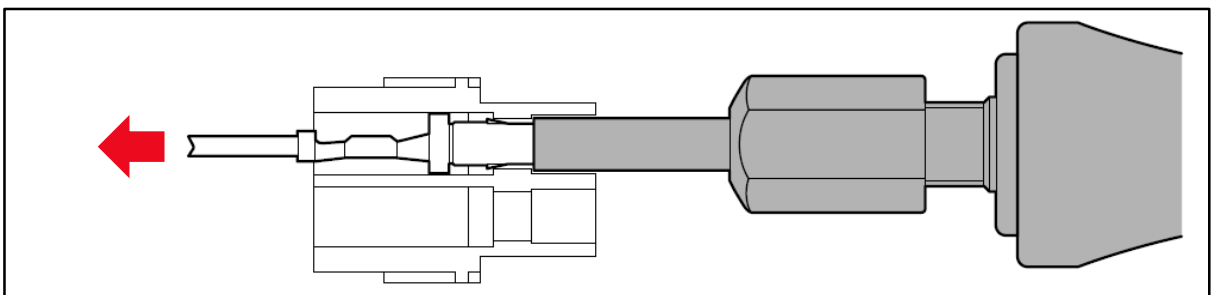
3. Push the handle through, grasp the lead, and push the wire terminal.

Figure 12.



4. The wire terminal is ejected.

Figure 13.



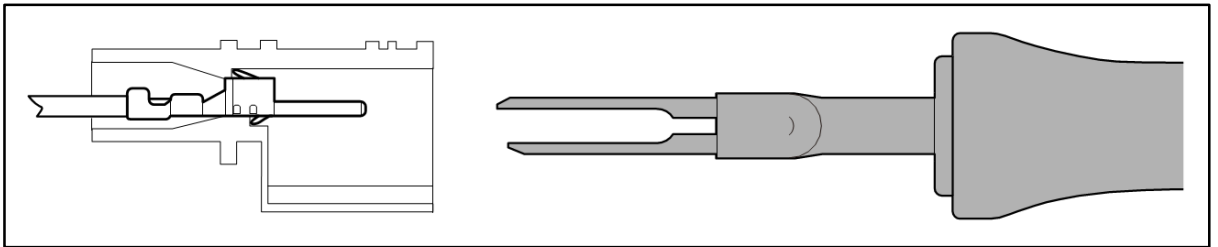
Wire Harness, Wire Terminal, and Connector Repair Procedures

Terminal Release Method Examples (continued)

Asymmetrical Flat Terminal Systems

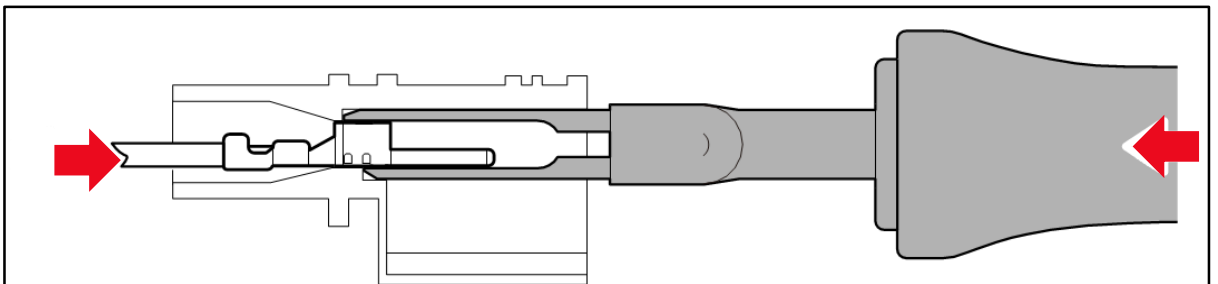
1. Remove the spacers or unlock the secondary locks using the appropriate tool if necessary.
2. Insert the tool into the locking lance to remove the primary lock.

Figure 14.



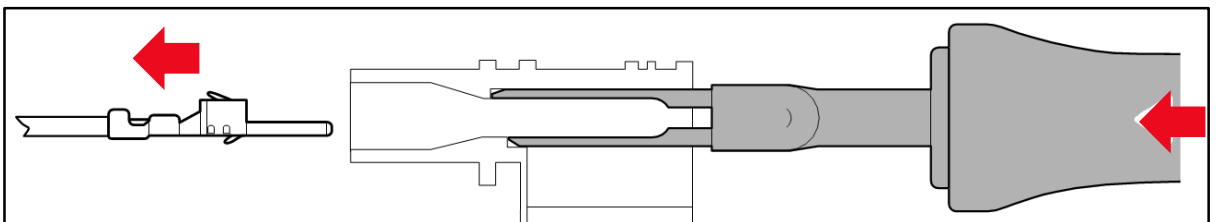
3. Grasp the lead and push the wire terminal in order to release the connector shoulder locking lance.

Figure 15.



4. Pull the wire terminal out of the connector.

Figure 16.



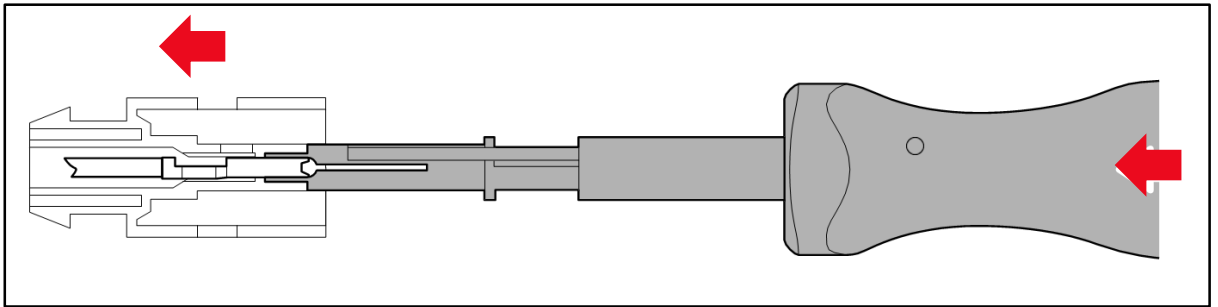
Wire Harness, Wire Terminal, and Connector Repair Procedures

Terminal Release Method Examples (continued)

Flat Terminals SLK 2.8 mm Without Secondary Lock

1. Insert the tool into the locking lance and push the handle through.
2. The wire terminal is ejected.

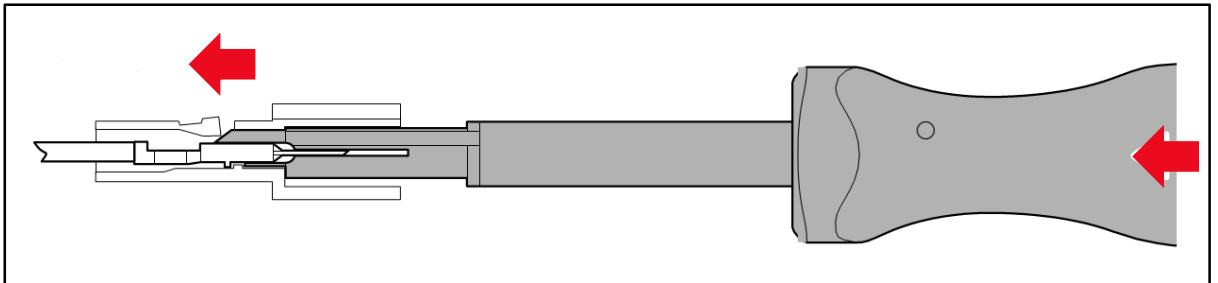
Figure 17.



Flat Terminals SLK 2.8 mm With Secondary Lock

1. Insert the tool into the locking lance.
2. Push the lead with your finger into the tool blade.

Figure 18.



Wire Harness, Wire Terminal, and Connector Repair Procedures

Connector Type Examples

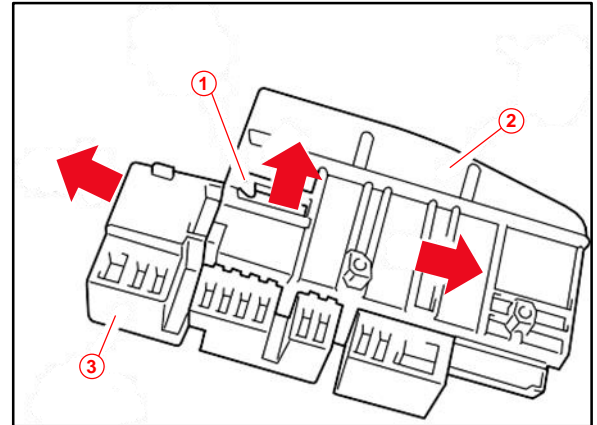
Type A Connector (Type 1)

1. Press the locks on the protective cap upward on both sides.
2. Detach the protective cap from the connector.

HINT

Detaching the protective cap releases the socket contact secondary locks.

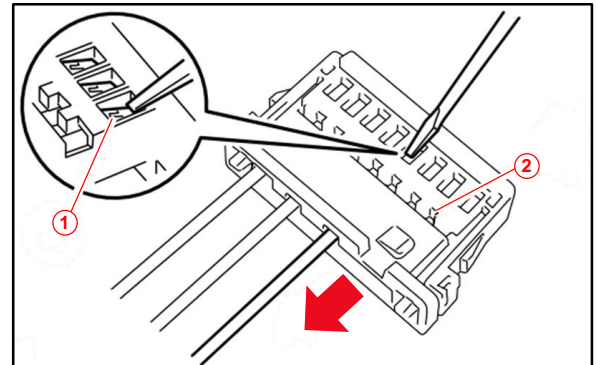
Figure 19.



1	Lock
2	Protective Cap
3	Connector

3. Hold down the retaining hook of the socket contact in the opening of the connector with a small screwdriver.
4. Pull the wire terminal in the direction of the arrow as far as the secondary lock.

Figure 20.



1	Retaining Hook
2	Secondary Lock

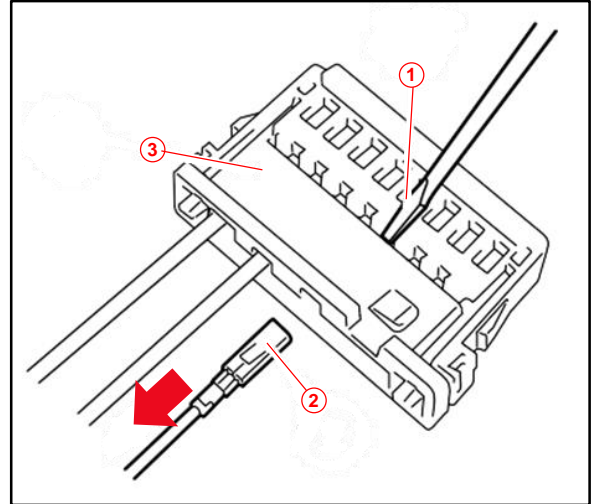
Wire Harness, Wire Terminal, and Connector Repair Procedures

Connector Type Examples (continued)

Type A Connector (Type 1) (continued)

5. Hold down the retaining hook in the secondary lock again and pull the wire terminal completely out of the connector.

Figure 21.



1	Secondary Lock
2	Wire Terminal
3	Connector

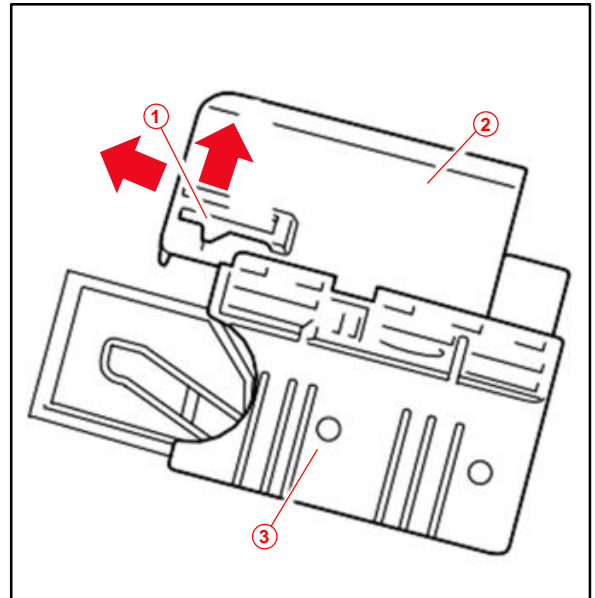
Type A Connector (Type 2)

1. Press the locks on the protective cap upward on both sides.
2. Detach protective cap from the connector block.

HINT

Detaching the protective cap releases the wire terminal secondary locks.

Figure 22.



1	Lock
2	Protective Cap
3	Connector Block

Wire Harness, Wire Terminal, and Connector Repair Procedures

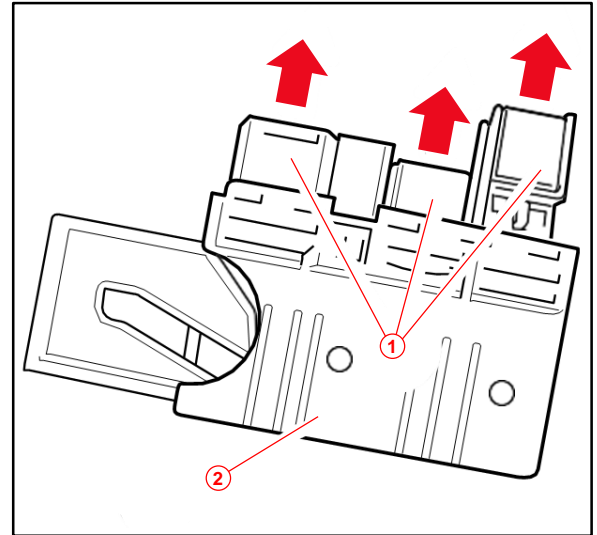
Connector Type Examples (continued)

Type A Connector (Type 2) (continued)

3. Pull the connector(s) out of the connector block.

4. Remove the wire terminals from the connector.

Figure 23.

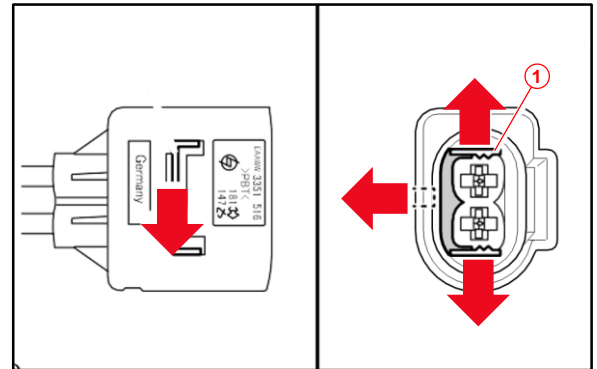


1	Connector
2	Connector Block

Type B Connector

1. Release the lock on the outside at the retaining hook and slide it to the side.

Figure 24.



1	Lock
----------	-------------

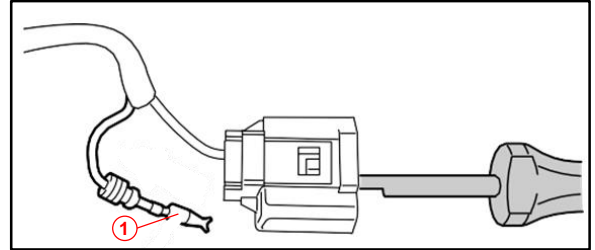
Wire Harness, Wire Terminal, and Connector Repair Procedures

Connector Type Examples (continued)

Type B Connector (continued)

2. Unlock wire terminal and pull it back.

Figure 25.

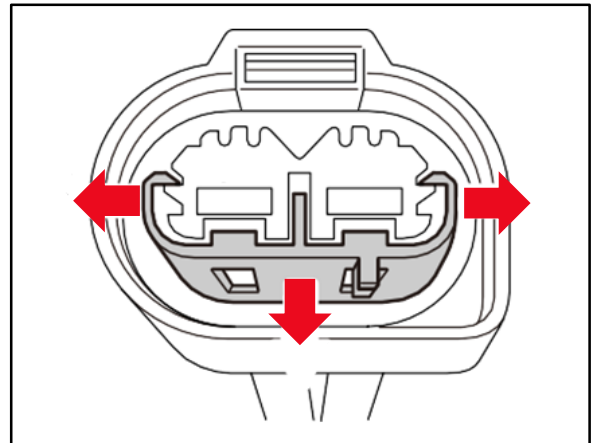


1	Wire Terminal
----------	----------------------

Type C Connector

1. Press the clips on the outside in the direction of the arrow and remove the secondary lock upward.

Figure 26.



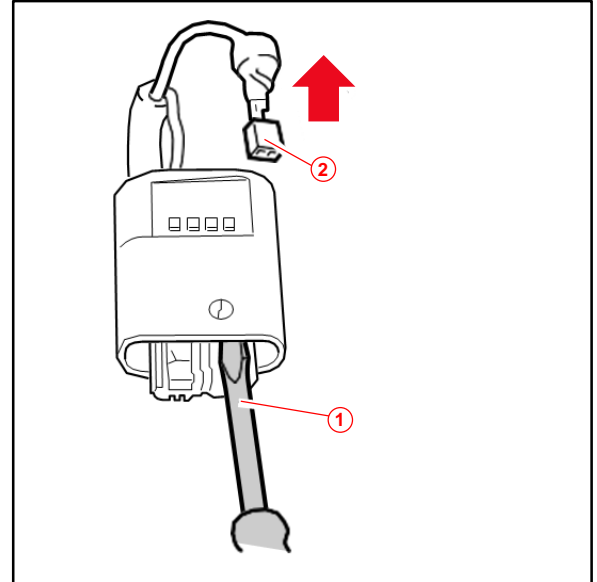
Wire Harness, Wire Terminal, and Connector Repair Procedures

Connector Type Examples (continued)

Type C Connector (continued)

2. Press down the retaining hook with a screwdriver and pull back the wire terminal.

Figure 27.

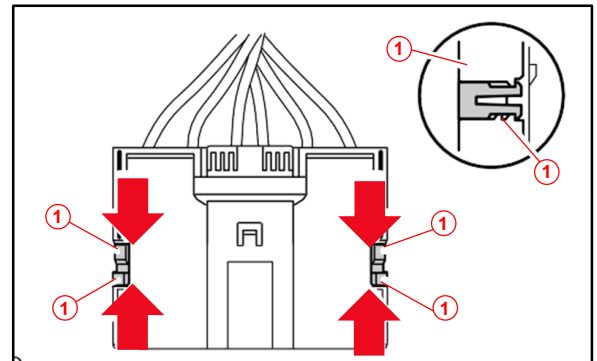


1	Retaining Hook
2	Wire terminal

Type D Connector

1. Press the locking hook in the direction of the arrow and disengage.
2. Unlock the locking hook.

Figure 28.



1	Locking Hook
---	--------------

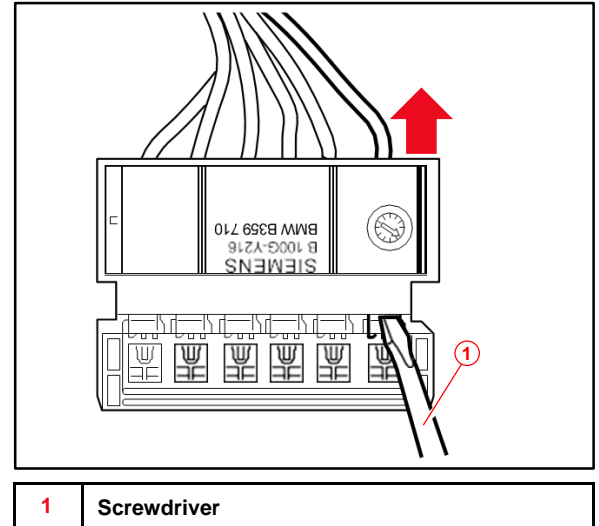
Wire Harness, Wire Terminal, and Connector Repair Procedures

Connector Type Examples (continued)

Type D Connector (continued)

3. Press down the retaining hook with a screwdriver and pull back the wire terminal.

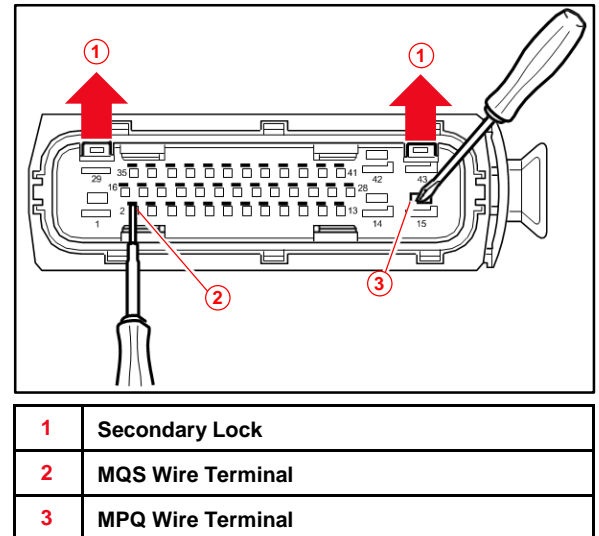
Figure 29.



Type E Connector

1. Open the secondary locks on the connector.
2. Press back the MQS wire terminal retaining hook and pull the wire terminal out.
3. Press back the MPQ wire terminal retaining hook with a screwdriver and pull the wire terminal out.

Figure 30.



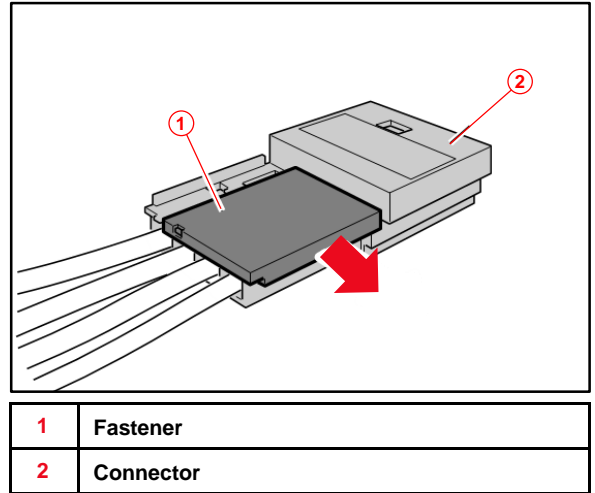
Wire Harness, Wire Terminal, and Connector Repair Procedures

Connector Type Examples (continued)

Type F Connector

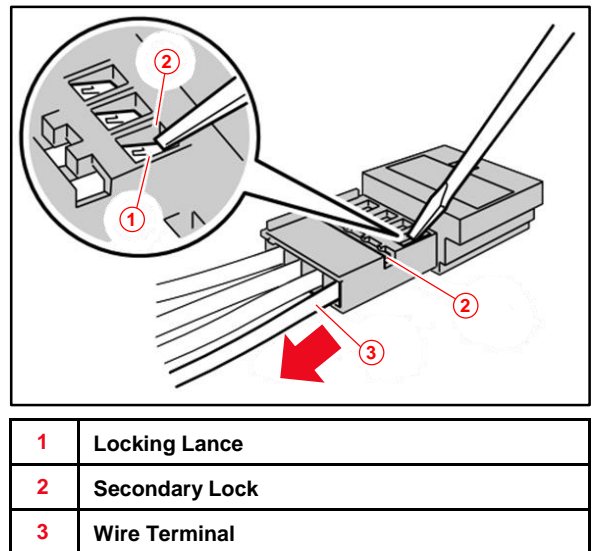
1. Detach the fastener from the connector.

Figure 31.



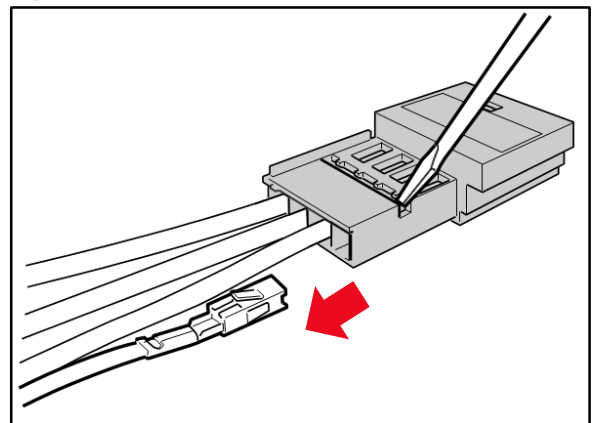
2. Hold down the defective wire terminal locking lance and pull the wire terminal back to the secondary lock.

Figure 32.



3. Hold down the secondary lock retaining hook and pull the wire terminal completely out of the connector.

Figure 33.



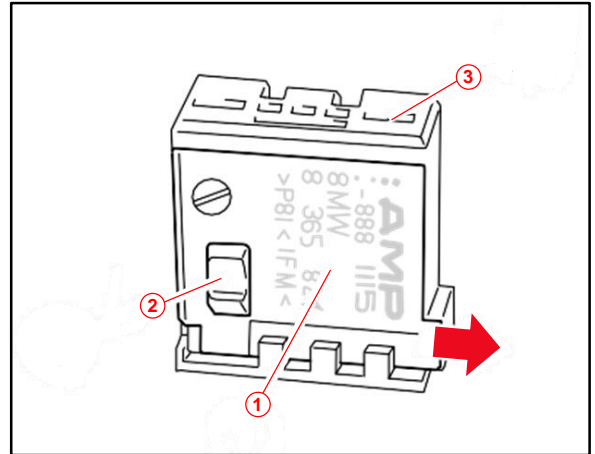
Wire Harness, Wire Terminal, and Connector Repair Procedures

Connector Type Examples (continued)

Type G Connector (Type 1)

1. Raise the fastener over the retaining lug and pull it off the connector.

Figure 34.

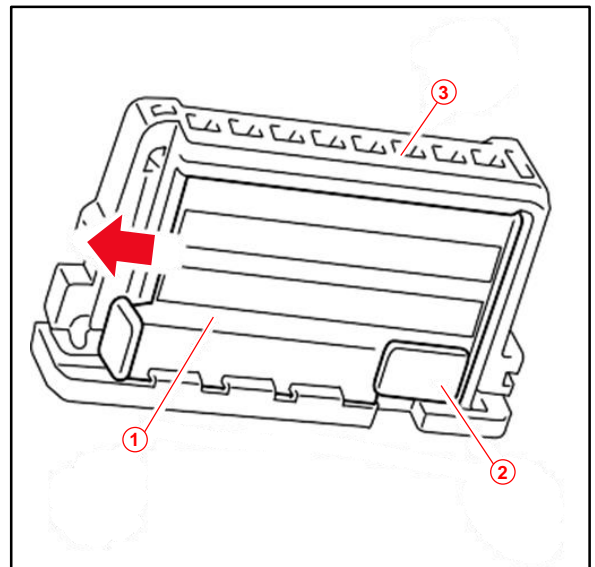


1	Fastener
2	Retaining Lug
3	Connector

Type G Connector (Type 2)

1. Raise the fastener over the retaining lug and pull it off the connector.

Figure 35.



1	Fastener
2	Retaining Lug
3	Connector

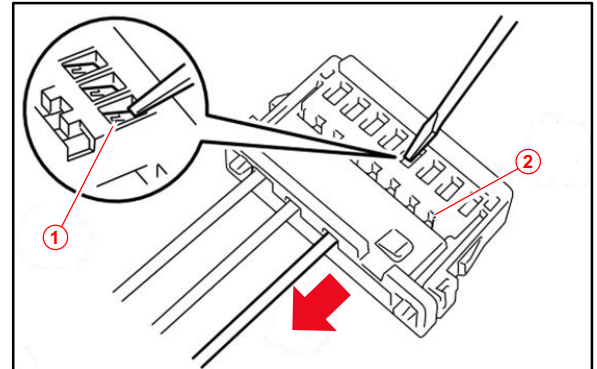
Wire Harness, Wire Terminal, and Connector Repair Procedures

Connector Type Examples (continued)

Type G Connector (Type 2) (continued)

2. Hold down the wire terminal retaining hook and pull the wire terminal out as far as the secondary lock.

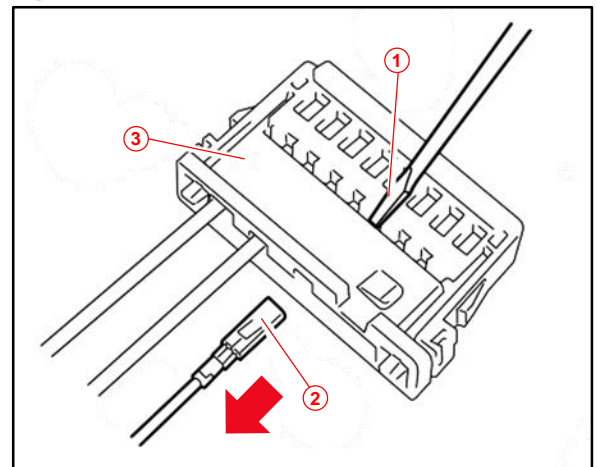
Figure 36.



1	Retaining Hook
2	Secondary Lock

3. Hold down the retaining hook in the secondary lock again and pull the wire terminal completely out of the connector.

Figure 37.



1	Secondary Lock
2	Wire Terminal
3	Connector

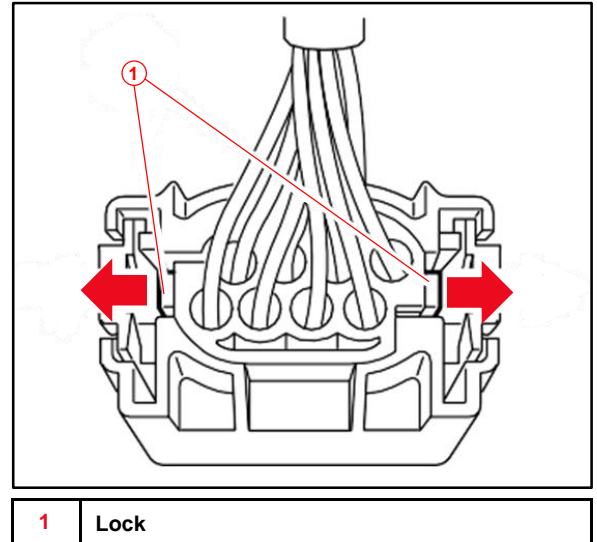
Wire Harness, Wire Terminal, and Connector Repair Procedures

Connector Type Examples (continued)

Type H Connector

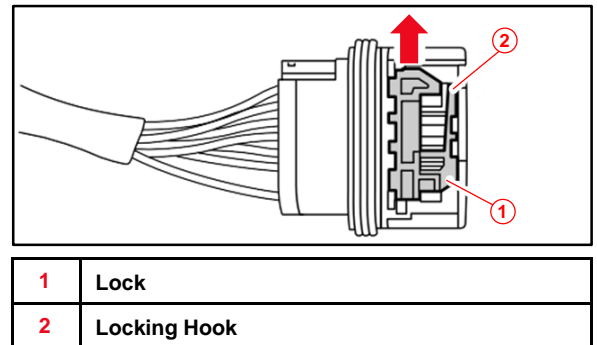
1. Press the lock in the direction of the arrow and slide the connector forward.

Figure 38.



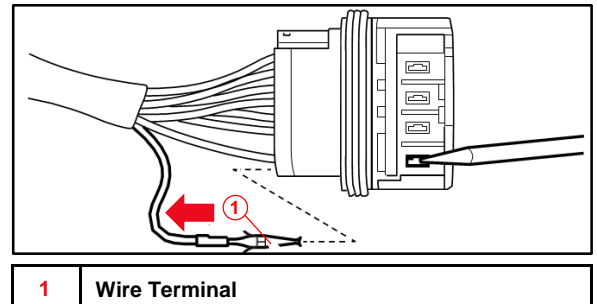
2. Press the locking hook downward and slide the lock out.

Figure 39.



3. Press down the retaining hook with a screwdriver and pull out the wire terminal.

Figure 40.



Wire Harness, Wire Terminal, and Connector Repair Procedures

Connector Type Examples (continued)

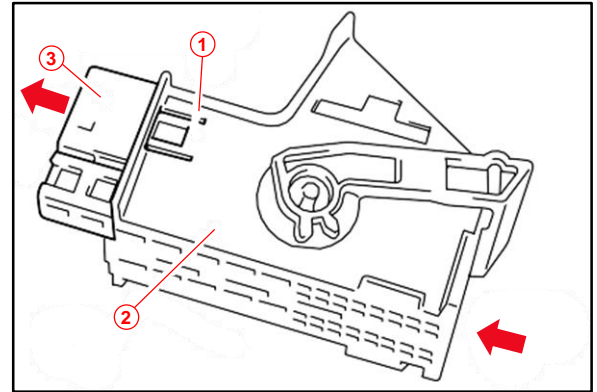
Type I Connector

1. Raise the lock on the connector block.
2. Push the connector out of the connector block.

HINT

- The second connector is pushed out in the same way.
- Pushing out the connector releases the secondary locks.

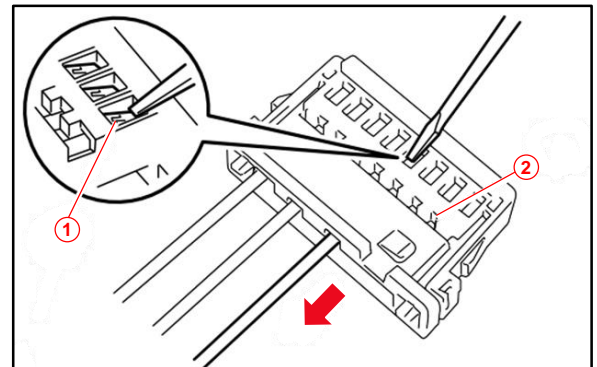
Figure 41.



1	Lock
2	Connector Block
3	Connector

3. Hold down the wire terminal retaining hook in the connector using a small screwdriver.
4. Pull the wire terminal in the direction of the arrow as far as the secondary lock.

Figure 42.



1	Retaining Hook
2	Secondary Lock

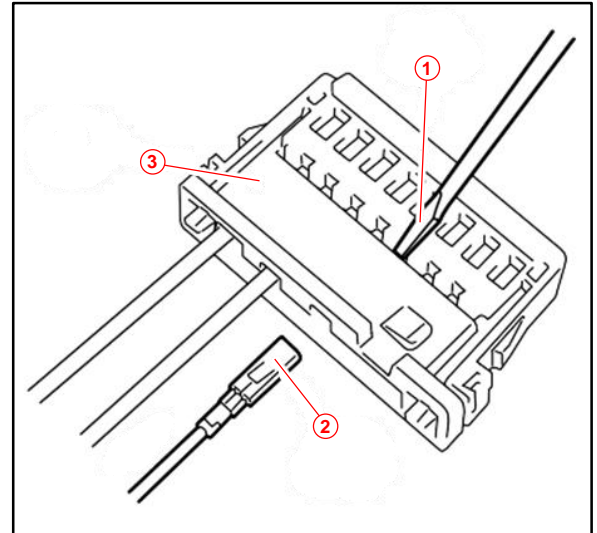
Wire Harness, Wire Terminal, and Connector Repair Procedures

Connector Type Examples (continued)

Type I Connector (continued)

5. Hold down the retaining hook in the secondary lock again and pull the wire terminal completely out of the connector.

Figure 43.

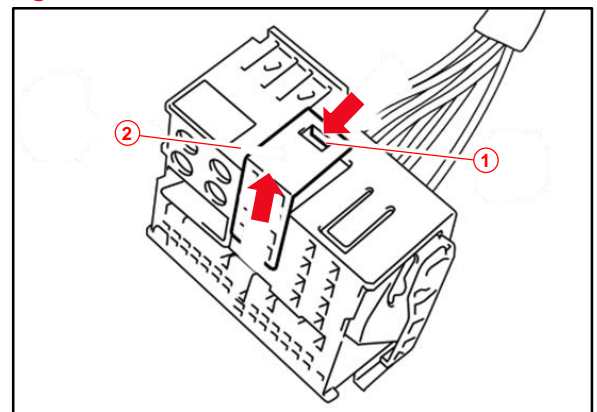


1	Secondary Lock
2	Wire Terminal
3	Connector

Type J Connector (Type 1)

1. Press the lock in the direction of the arrow.
2. Detach the secondary lock from the radio plug.
3. Feed the SST past the wire terminal side.
4. Press the SST in the direction of the arrow.

Figure 44.



1	Lock
2	Secondary Lock

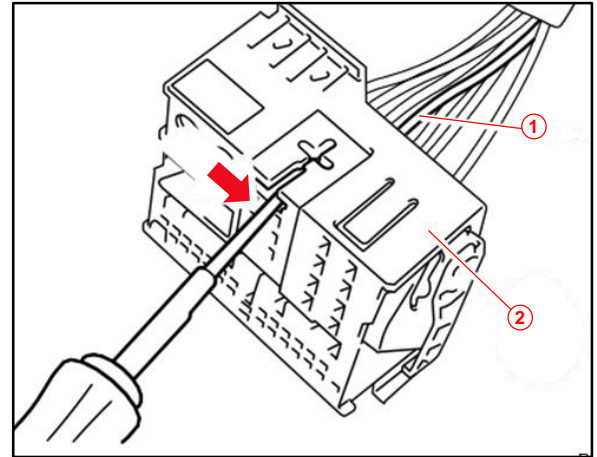
Wire Harness, Wire Terminal, and Connector Repair Procedures

Connector Type Examples (continued)

Type J Connector (Type 1) (continued)

5. Pull the wire terminal out of the connector.

Figure 45.

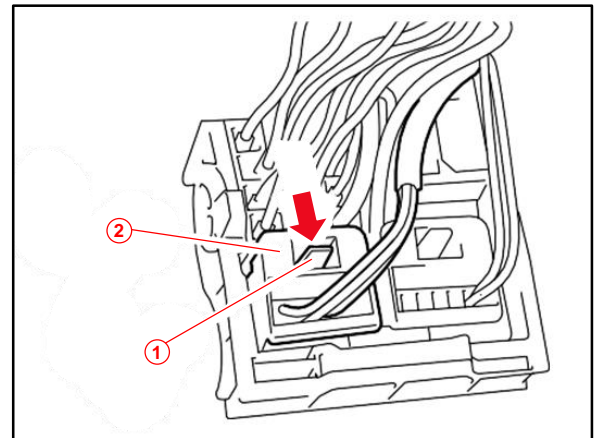


1	Wire Terminal
2	Connector

Type J Connector (Type 2)

1. Press the lock in the direction of the arrow and pull the connector out of the connector block.

Figure 46.



1	Lock
2	Connector

Wire Harness, Wire Terminal, and Connector Repair Procedures

Connector Type Examples (continued)

Type J Connector (Type 2) (continued)

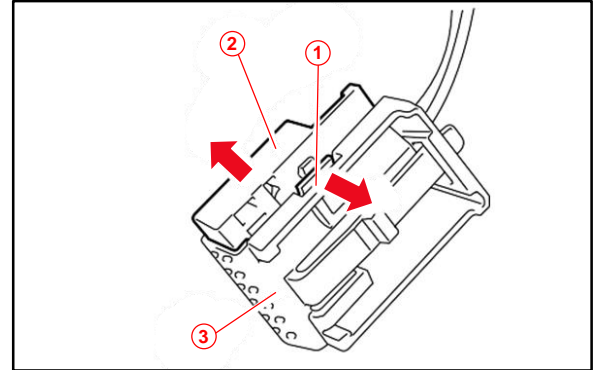
2. Press the lock in the direction of the arrow.

3. Pull the connector out of the housing.

HINT

The secondary locks are raised when the connector is pulled out.

Figure 47.

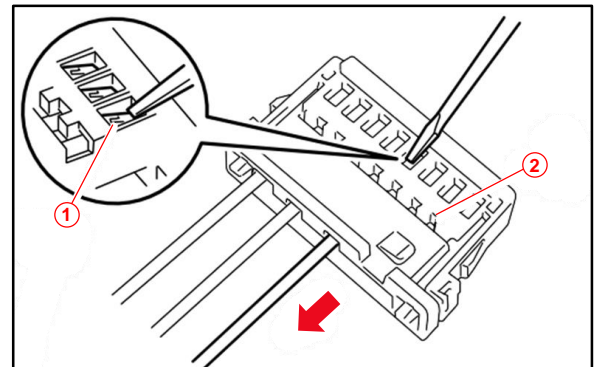


1	Lock
2	Connector
3	Housing

4. Hold down the wire terminal retaining hook in the connector opening with a small screwdriver.

5. Pull the wire terminal in the direction of the arrow as far as the secondary lock.

Figure 48.



1	Retaining Hook
2	Secondary Lock

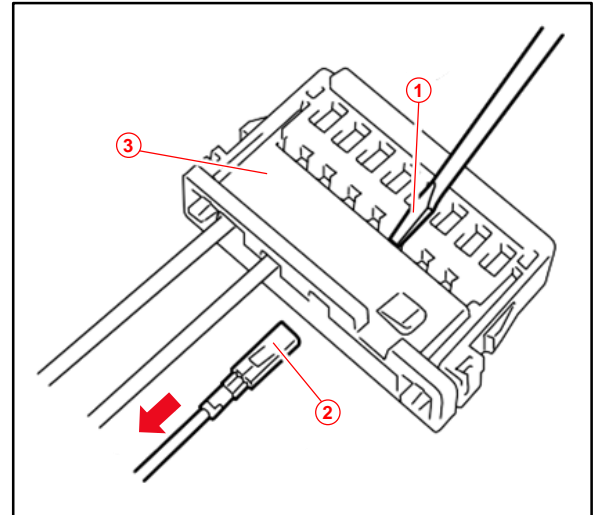
Wire Harness, Wire Terminal, and Connector Repair Procedures

Connector Type Examples (continued)

Type J Connector (Type 2) (continued)

6. Hold down the retaining hook in the secondary lock again. Pull the wire terminal completely out of the connector.

Figure 49.

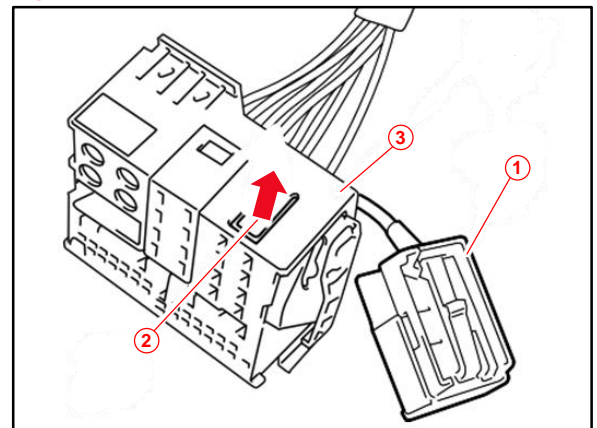


1	Secondary Lock
2	Wire Terminal
3	Connector

Type J Connector (Type 3)

1. Remove the connector with MQS wire terminals from the radio connector.
2. Raise the lock on the radio connector.
3. Pull the connector with MQS wire terminals out of the radio connector.

Figure 50.



1	Connector With MQS Wire Terminals
2	Lock
3	Radio Connector

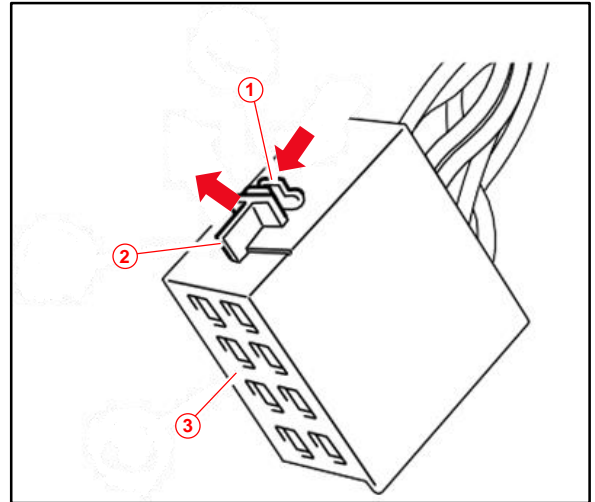
Wire Harness, Wire Terminal, and Connector Repair Procedures

Connector Type Examples (continued)

Type J Connector (Type 3) (continued)

4. Press the lock in the direction of the arrow.
5. Pull the secondary lock in the direction of the arrow completely out of the connector.

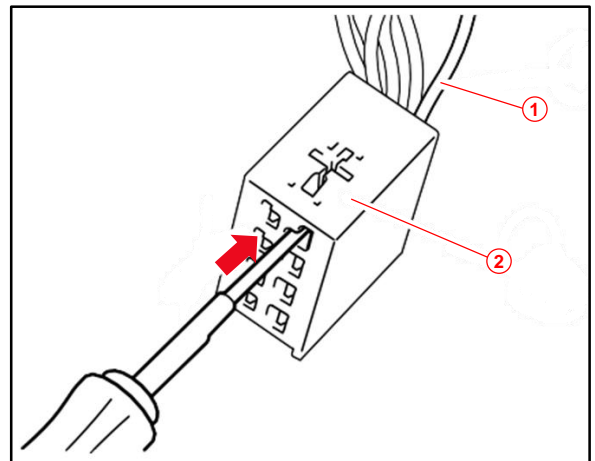
Figure 51.



1	Lock
2	Secondary Lock
3	Connector

6. Press the SST inside of the wire terminal into the connector.
7. Pull the wire terminal out of the connector.

Figure 52.



1	Wire Terminal
2	Connector

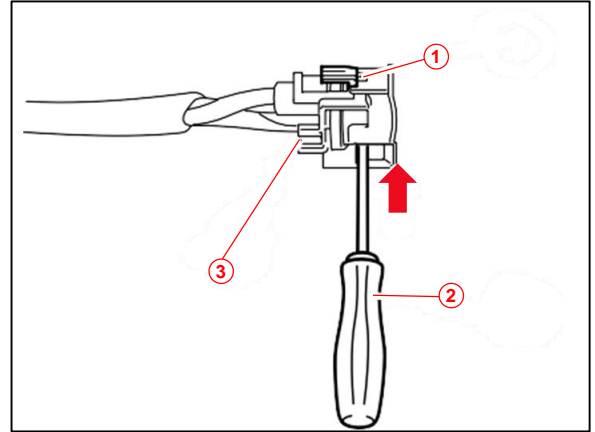
Wire Harness, Wire Terminal, and Connector Repair Procedures

Connector Type Examples (continued)

Type K Connector (Type 1)

1. Press the lock out of the connector in the direction of the arrow with a suitable tool.

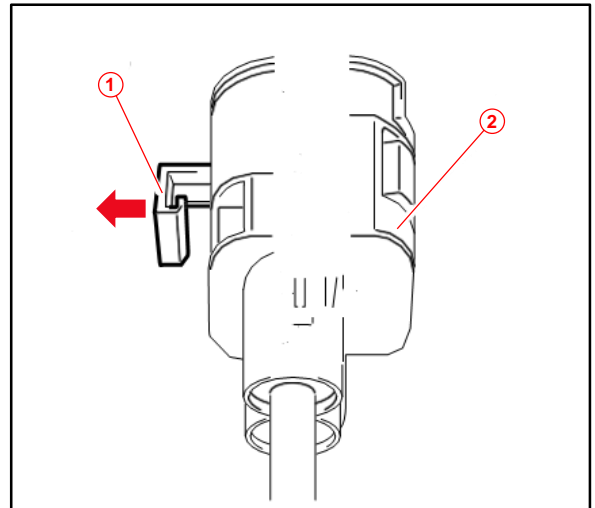
Figure 53.



1	Lock
2	Suitable Tool
3	Connector

2. Pull the lock out of the connector.

Figure 54.



1	Lock
2	Socket Housing

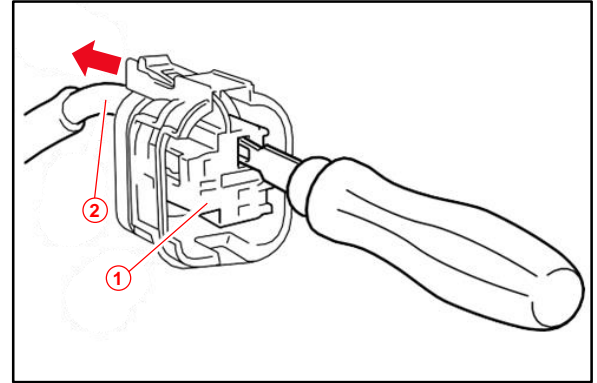
Wire Harness, Wire Terminal, and Connector Repair Procedures

Connector Type Examples (continued)

Type K Connector (Type 1) (continued)

3. Insert the SST into the connector and pull out the wire terminal in the direction of the arrow.

Figure 55.

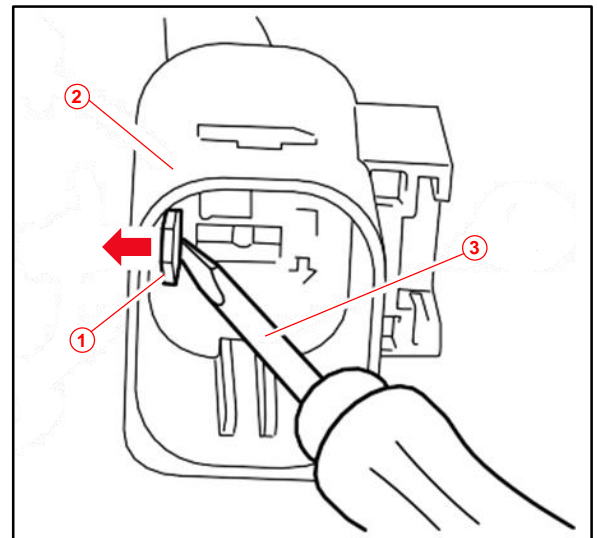


1	Socket Housing
2	Wire Terminal

Type K Connector (Type 2)

1. Unlock the connector locking slide in direction of arrow with a suitable tool.

Figure 56.



1	Connector Locking Side
2	Suitable Tool

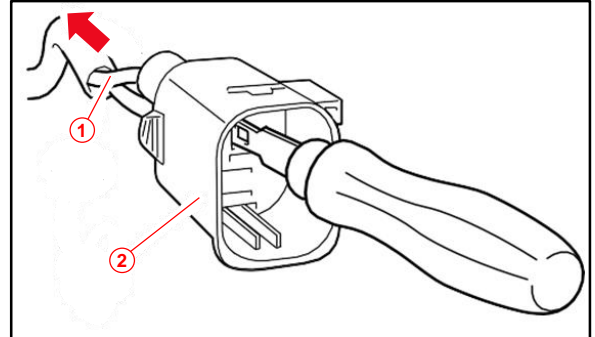
Wire Harness, Wire Terminal, and Connector Repair Procedures

Connector Type Examples (continued)

Type K Connector (Type 2) (continued)

2. Insert the SST into the connector and pull out the wire terminal in the direction of the arrow.

Figure 57.

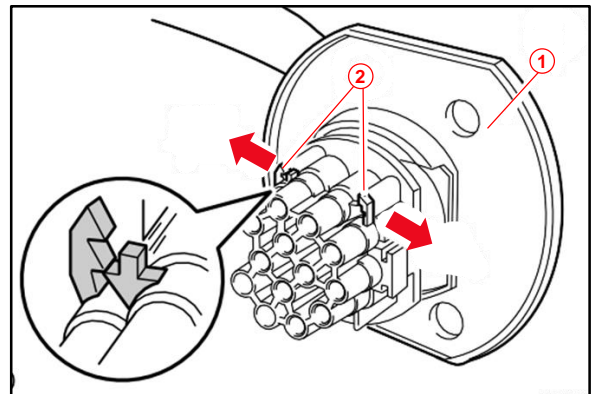


1	Connector
2	Wire Terminal

Type L Connector

1. Pull off the rubber grommet.
2. Carefully pull out the lock in the direction of the arrow.

Figure 58.



1	Rubber Grommet
2	Lock

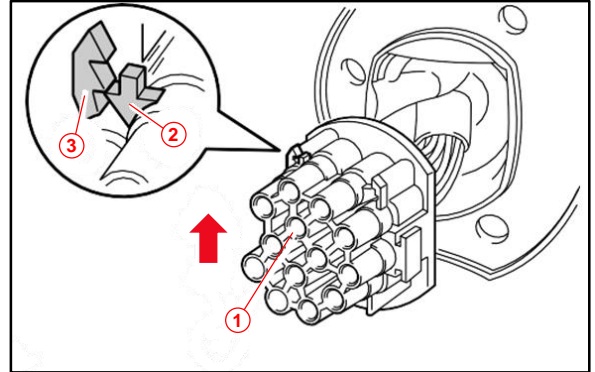
Wire Harness, Wire Terminal, and Connector Repair Procedures

Connector Type Examples (continued)

Type L Connector (continued)

3. Move the lower section of the connector in the direction of the arrow until the retaining lugs snap into the release groove.

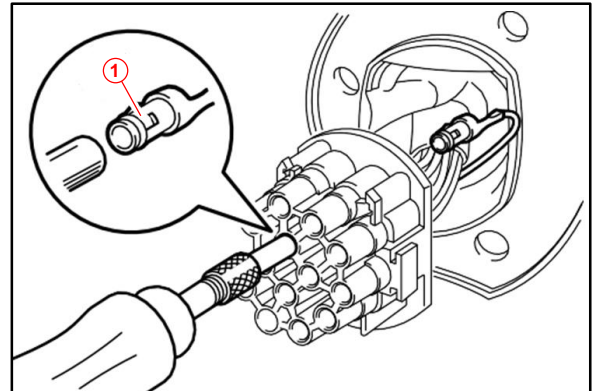
Figure 59.



1	Connector
2	Retaining Lugs
3	Release Groove

4. With the SST, press down on the corresponding contact retaining lugs and pull out the wire terminal.

Figure 60.



1	Retaining lugs
----------	----------------

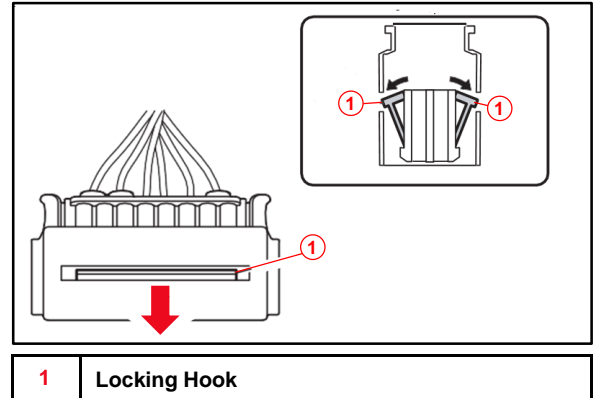
Wire Harness, Wire Terminal, and Connector Repair Procedures

Connector Type Examples (continued)

Type M Connector

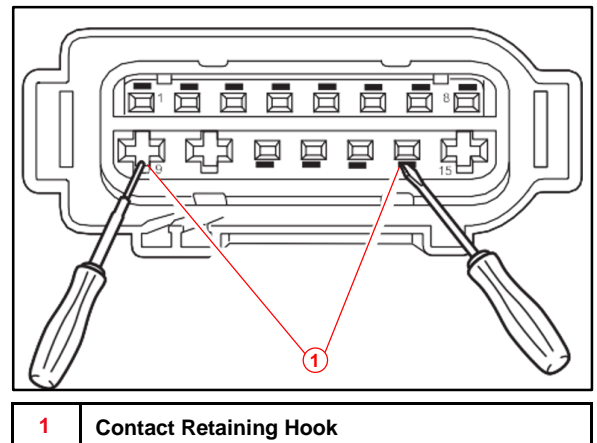
1. Press the locking hook in the direction of the arrow and disengage.

Figure 61.



2. Press back the wire terminal retaining hook with the SST and pull out the wire terminal.
3. Press back the wire terminal retaining hook with a screwdriver and pull out wire terminal.

Figure 62.



Wire Harness, Wire Terminal, and Connector Repair Procedures

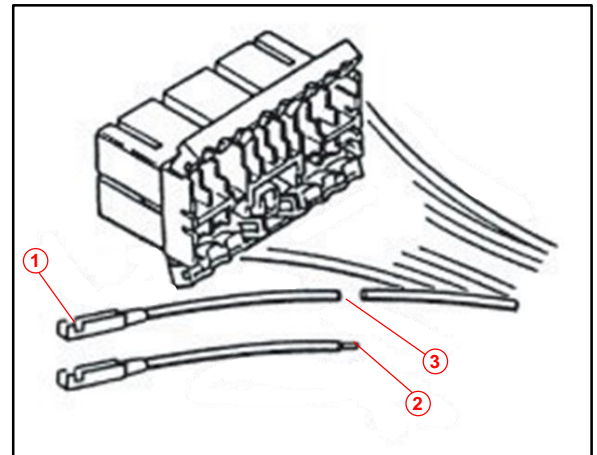
Wire Terminal Replacement

1. Use the NEW wire lead as a guide for proper length.

HINT

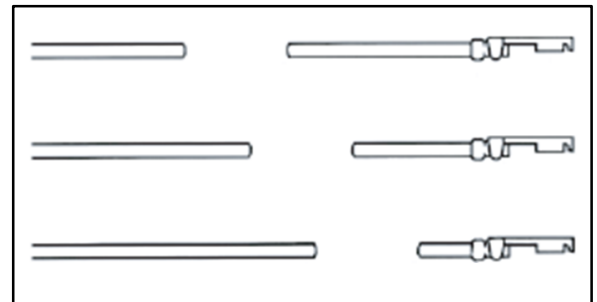
- If the length of the removed wire is NOT approximately the same length as the NEW wire, the following problems may develop:
 - Too short: tension on the terminal, splice, or the connector, causing an open circuit.
 - Too long: excessive wire near the connector, may get pinched or abraded, causing a short circuit.
- When repairing three or more wire terminals, cut the wires as shown in Figure 64 in order to achieve connector sleeve staggering.

Figure 63.



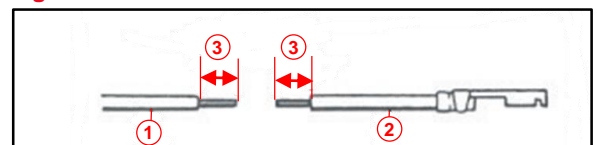
1	Existing Terminal
2	Repair Wire
3	Cut

Figure 64.



2. Remove insulation from the existing wire and repair the terminal wire.
 - A. Start stripping at least 8 mm – 11 mm away from the end of the existing harness, and from the end of the repair wire.

Figure 65.



1	Existing Harness
2	Repair Wire
3	8 mm – 11 mm

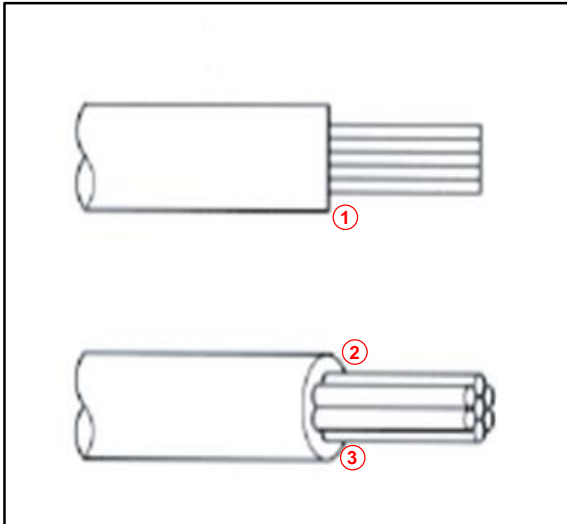
Wire Harness, Wire Terminal, and Connector Repair Procedures

Wire Terminal Replacement

NOTICE

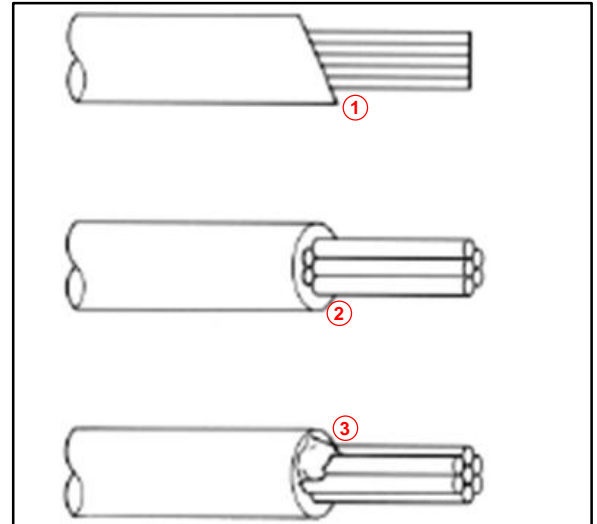
- Do NOT damage or cut the wire strand.
- AFTER the insulation is removed, visually check the wire. If ANY damage is found, repeat the insulation removal.

Figure 66. Good Examples



1	Wire Insulation Stripped Correctly
2	Wire Lead Not Cut
3	No Insulation Remains on the Lead

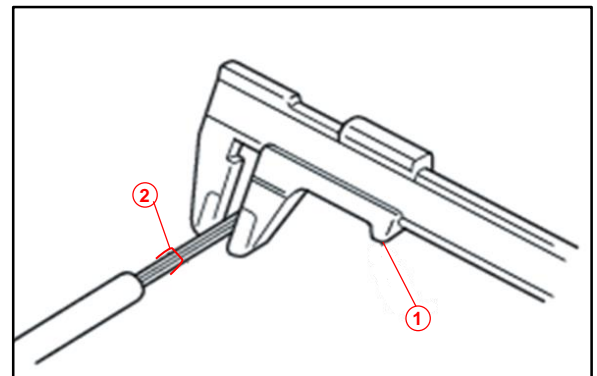
Figure 67. Bad Examples



1	Wire insulation Stripped at a Slant
2	Wire Lead Is Cut
3	Insulation Remains on the Lead

3. Select the correct sleeve size from the parts supply.
 - A. Using a caliper, measure the outer diameter of the wire or the diameter of the wire strand.
 - B. To calculate the nominal size of the wire, use the following formula:
Nominal size = 3.14 x (diameter of wire lead)²/4.

Figure 68. Nominal Wire Size



1	Calipers
2	Wire Lead Diameter

Wire Harness, Wire Terminal, and Connector Repair Procedures

Wire Terminal Replacement (continued)

- Verify the sleeve type. Select the appropriate sleeve by referring to the table shown.

Table 5. Sleeve Size

NOMINAL WIRE SIZE (MM ²)	SLEEVE SIZE (COLOR)
0.5	SS (Silver)
0.75 – 1.0	S (Silver)
1.25 – 2.5	M (Silver)
3.0 – 5.0	L (Silver)

- Join the strands of the existing wire and new terminal wire.

NOTICE

An improper wire connection may occur if unauthorized work procedures are conducted, or if crimping tools or sleeves are used in aluminum wire repairs.

- Using the table shown, confirm the appropriate sleeve and crimp size.

Table 6.

SLEEVE SIZE	CRIMP SIZE	CRIMP MARK
SS	0.5	0
S	1.25	1
M	2	2
L	5.5	5

Figure 69.

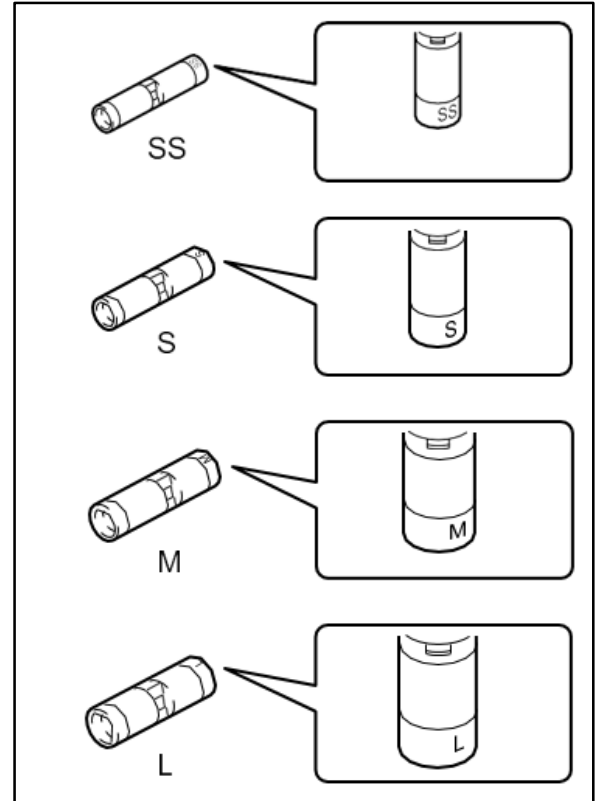


Figure 70. Crimping Tool S

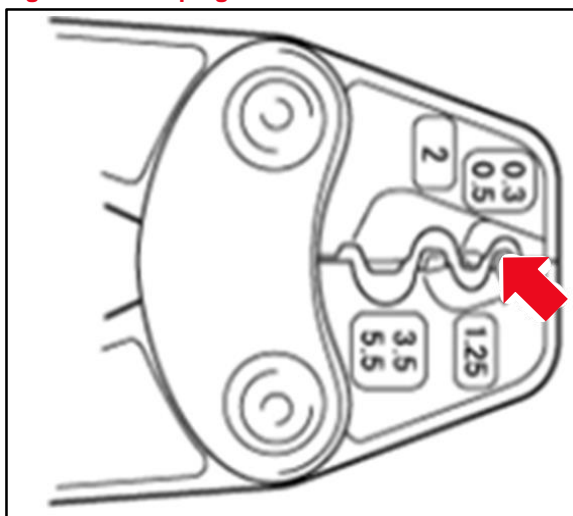
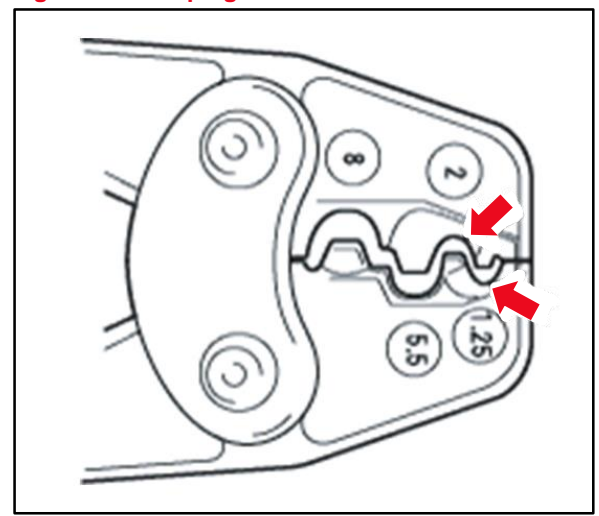


Figure 71. Crimping Tool



Wire Harness, Wire Terminal, and Connector Repair Procedures

Wire Terminal Replacement (continued)

- B. Squeeze the tool handles to disengage the ratchet.
- C. Place the sleeve in the crimping area of the tool and hold the tool handles to hold the sleeve.

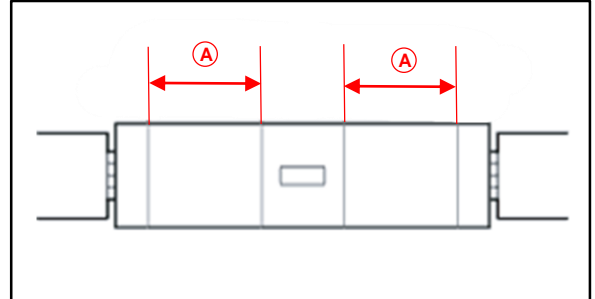
HINT

Hold area A shown.

NOTICE

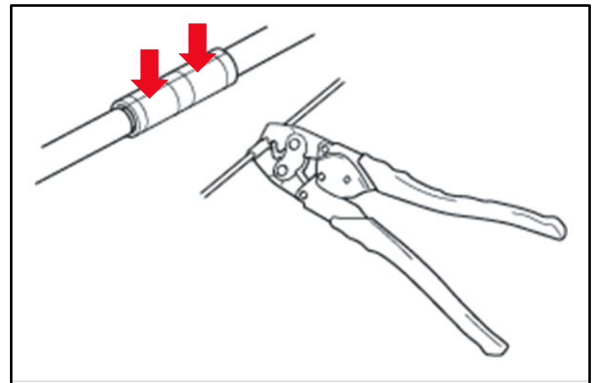
Ensure that the protrusion of the tool's crimping portion will come into contact with the sleeve seam.

Figure 72.



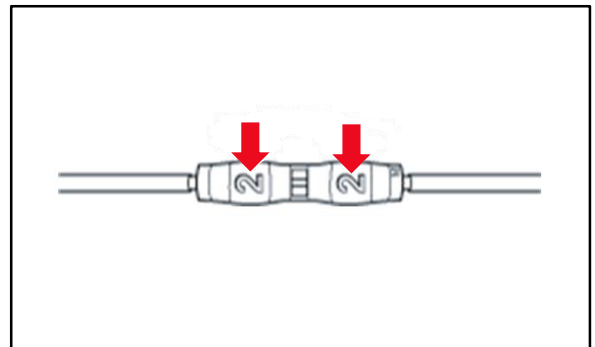
- D. Insert the wire into the sleeve as far as it can go.

Figure 73.



- E. Squeeze the tool handles until the ratchet disengages again.
- F. Check that the crimp mark is correct.

Figure 74.



Wire Harness, Wire Terminal, and Connector Repair Procedures

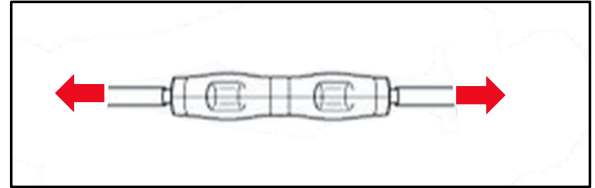
Wire Terminal Replacement (continued)

- G. Pull the connected wires to check that they have been securely connected.

NOTICE

If the connected wires are pulled out from the crimped sleeve or if crimping has failed, replace the sleeve with a new one and repeat crimping.

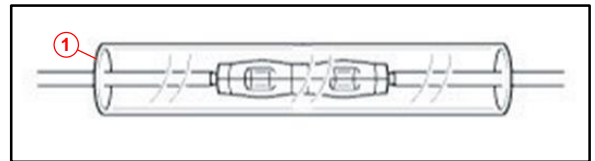
Figure 75.



- H. Waterproof and insulate the joint area.

- (1) Cover the joints with heat shrink sleeves and position the joints at the center of the sleeves.

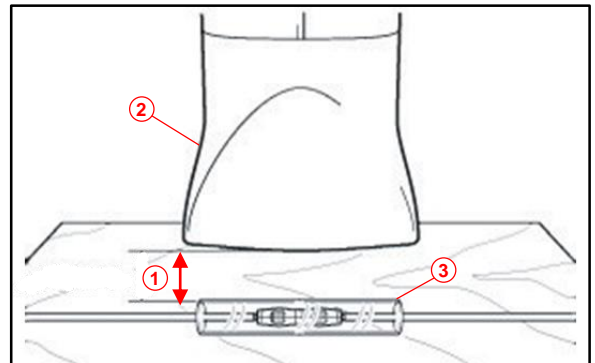
Figure 76.



1	Heat Shrink Sleeve
----------	--------------------

- (2) Using a dryer or heat gun, apply hot air to the heat shrink sleeve for about 10 seconds.
- (3) When a dryer is used, keep it about 10 mm away from the shrink sleeve.

Figure 77.



1	10 mm
2	Dryer
3	Heat Shrink Sleeve

CAUTION

Keep hands and other body parts away from the heat to avoid burn injuries.

Wire Harness, Wire Terminal, and Connector Repair Procedures

Wire Terminal Replacement (continued)

- (4) When a heat gun is used, keep it 100 mm – 200 mm away from the shrink sleeve.

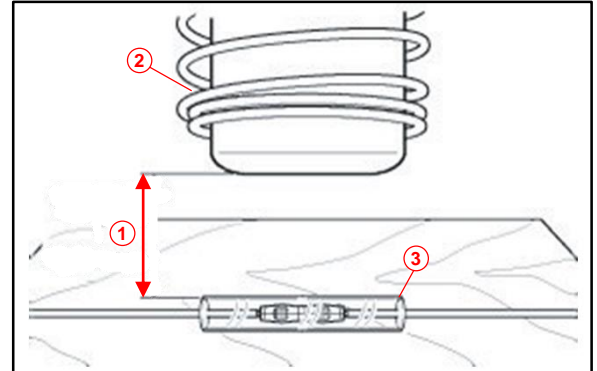
NOTICE

Use a wooden plate to prevent hot air from being applied to other wires.

CAUTION

Keep hands and other body parts away from the heat to avoid burn injuries.

Figure 78.



1	100 mm – 200 mm
2	Heat Gun
3	Heat Shrink Sleeve

- (5) Turn OFF the dryer or heat gun, and check if a resin substance has come out of the gap between the shrink sleeve and wire at each sleeve end. Repeat the heating procedure described above until resin substances come out.

Figure 79.

