



Technical Service Bulletin

34 Special diagnosis instructions: hydraulic pump checking

34 21 51 2050725/2 March 8, 2021. Supersedes Technical Service Bulletin Group 34 number 18-33 dated June 27, 2018 for reasons listed below.

Model(s)	Year	VIN Range	Vehicle-Specific Equipment
A3	2017	All	0GC 7 speed S-tronic transmissions
A3	2018	000001 - 022977	0GC 7 speed S-tronic transmissions

Condition

REVISION HISTORY		
Revision	Date	Purpose
2	-	Revised <i>Warranty</i> (Updated Time Units) Revised <i>Required Parts and Tools</i> (Updated Table)
1	07/27/2018	Initial publication

Depending on the DTCs that are stored in the transmission control module (TCM) the Audi Technical Assistance Center may request you perform this Technical Service Bulletin to diagnose the correct repair for the vehicle.



Tip: Only use this Technical Service Bulletin if the Audi Technical Assistance Center (TAC) has directed you to perform it.

Technical Background

The cover of the auxiliary hydraulic pump inside the gearbox might be loose or out of specification.

The final drive gear could chafe on the pump cover of the auxiliary hydraulic pump.

To see the drive shaft of the auxiliary hydraulic pump, the pump motor (Figure 1, position 3) has to be removed. The depth of the drive shaft can be used to check the cover position.



Technical Service Bulletin

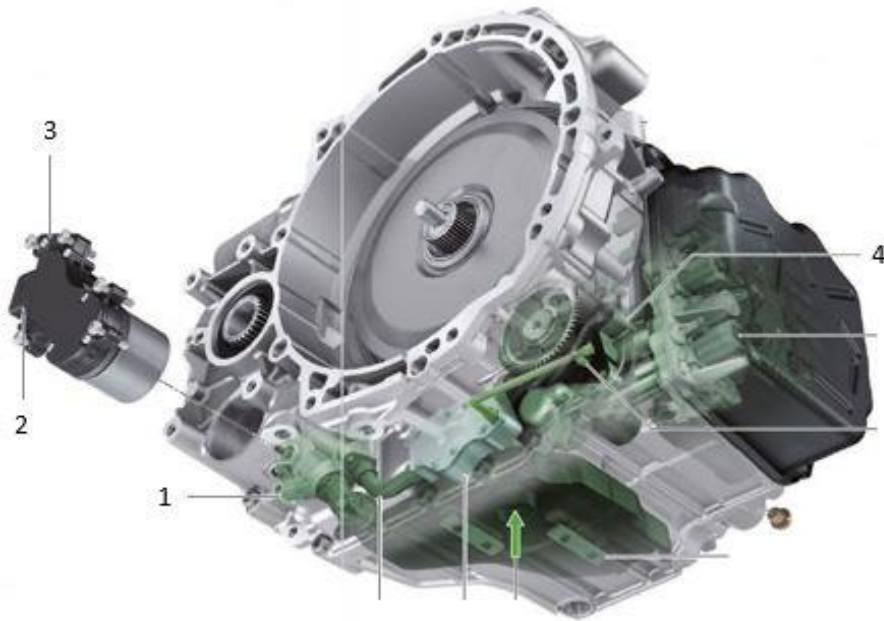

Figure 1. OGC gearbox parts.

Position 1: Auxiliary mechanical hydraulic pump (driven by V475).

Position 2: Electrical connection of Transmission Fluid Auxiliary Hydraulic Pump 1 V475.

Position 3: Transmission Fluid Auxiliary Hydraulic Pump 1 V475.

Position 4: Main ATF pump (driven by the transmission input shaft).

Production Solution

Improvements to the auxiliary hydraulic pump.

Service

If you have not already provided the transmission code and identification information (Figure 2) to the Audi Technical Assistance Center please enter the information into the contact. The procedure is only for transmissions built before a certain date. The Audi Technical Assistance Center needs this information before this TSB can be performed.

The transmission code and identification information are engraved on the transmission (Figure 2). In the example of Figure 2:

- Transmission code = STA.



Technical Service Bulletin

- The transmission build date format is Day-Month-Year.
- The transmission production date: 300916 = 30.09.2016 or September 30th. 2016.



Figure 2. Transmission code and identification.

Audi Technical Assistance Center requires the production date. Once they have the production date and have directed you to perform this TSB, complete the following:

1. Check for metal shavings in the transmission:
 - a. Remove the mechatronic unit according to the repair manual.
 - b. Check the magnet for gear actuator 2/6 for metallic deposits. Look through the lower hole closest to the bellhousing (Figure 3) to see the selector fork magnet. The example shows the selector fork magnet with metallic deposits.
 - c. Take a picture of the magnet and attach the picture to the Audi Technical Assistance Center Contact.



Figure 3. Selector magnet for gear actuator 2/6.



Technical Service Bulletin

2. Checking axial clearance of the auxiliary mechanical hydraulic pump:
 - a. On Quattro vehicles, remove the bevel box according to the repair manual. If the vehicle is not Quattro then move on to the next step.
 - b. Remove the Transmission Fluid Auxiliary Hydraulic Pump 1 V475 according to the repair manual.



Tip: A cup of ATF may come out of the transmission when the V475 is removed.

- c. Now you can see the drive shaft of the auxiliary hydraulic pump. The auxiliary hydraulic pump in the transmission is constructed as shown in the example (Figure 4):

Position 1: The cover of the auxiliary hydraulic pump.

Position 2: Pump impeller.

Position 3: Drive shaft.

The drive shaft has an axial play, which is normal and shown. If the drive shaft has too much play (in direction of the large arrow), the cover (pos. 1) is loose and the drive shaft moves with the pump impeller, (pos. 2) toward the inside of the gearbox.

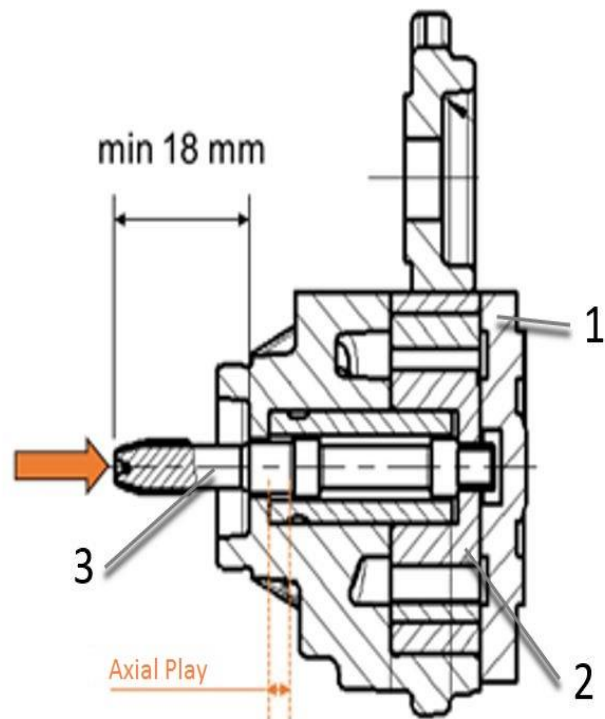

Figure 4. Structure of auxiliary hydraulic pump.

- d. Check the axial clearance of the drive shaft with a dial caliper. Position the caliper as shown in the examples below (Figure 5 and 6):



Technical Service Bulletin



Figure 5. Caliper positioning (transmission removed for pictures).



Figure 6. Close-up of the caliper positioning.

- f. Record the measurement to the 2nd decimal place for example: 18.02 mm.



Tip. Audi Technical Assistance Center Contact.

3. Attach your pictures and findings to the Technical Assistance Center Contact.
4. Contact the Audi Technical Assistance Center for the correct repair.

Warranty

Claim Type:	<ul style="list-style-type: none">• 110 up to 48 Months/50,000 Miles.• G10 for CPO Covered Vehicles – Verify Owner.• If the vehicle is outside any warranty, this Technical Service Bulletin is informational only.
Service Number:	3479
Damage Code:	0010



Technical Service Bulletin

Labor Operations:	Remove and install the mechatronic unit	3511 1915	See SRT with associated operations
	Check gearbox (for metal shavings)	3435 0199	10 TU
	Loosen and attach drive shaft (Front-wheel drive only)	4041 0999	40 TU
	Remove and install bevel box (Quattro Only)	3970 1912	See SRT with associated operations
	Remove and install hydraulic pump motor	3479 1999	30 TU
	Measure hydraulic pump shaft	3479 0399	30 TU
	Transmission remove + reinstall (Only with TAC Authorization)	3435 1999 (Quattro)	620 TU
		3435 1920 (Front Wheel Drive)	See SRT with associated operations
Diagnostic Time:	GFF	0150 0000	Time stated on diagnostic protocol (Max 90 TU)
	Road test prior to service procedure	No allowance	0 TU
	Road test after service procedure	0121 0004	10 TU
Claim Comment:	As per TSB #2050725/2		

All warranty claims submitted for payment must be in accordance with the *Audi Warranty Policies and Procedures Manual*. Claims are subject to review or audit by Audi Warranty.

Required Parts and Tools

Required parts cannot be included in this TSB as different repairs depend on the findings.

Tool Number	Tool Description
MCAL12A	MRT caliper (or equivalent)



Technical Service Bulletin

Additional Information

All parts and service references provided in this TSB (2050725) are subject to change and/or removal. Always check with your Parts Department and/or ETKA for the latest information and parts bulletins. Please check the Repair Manual for fasteners, bolts, nuts, and screws that require replacement during the repair.

©2021 Audi of America, Inc. All rights reserved. Information contained in this document is based on the latest information available at the time of printing and is subject to the copyright and other intellectual property rights of Audi of America, Inc., its affiliated companies, and its licensors. All rights are reserved to make changes at any time without notice. No part of this document may be reproduced, stored in a retrieval system, or transmitted in any form or by any means, electronic, mechanical, photocopying, recording, or otherwise, nor may these materials be modified or reposted to other sites without the prior expressed written permission of the publisher.