



SERVICE BULLETIN

Classification: EC19-004a	Reference: NTB19-036a	Date: February 3, 2021
------------------------------	--------------------------	---------------------------

2017-2018 GT-R; MIL ON WITH DTC P26DE

This bulletin has been amended. See **AMENDMENT HISTORY** on the last page.
Please discard previous versions of this bulletin.

APPLIED VEHICLES: 2017-2018 GT-R (R35)

IF YOU CONFIRM

The MIL is ON with DTC P26DE (ENGINE SOUND CONTROL “A” CIRCUIT PERFORMANCE) stored,

And

The cause is determined to be the electric control valve.

ACTION

1. Replace the electric control valve **ONLY**.
 - The electric control valve is now available separately as a service part.
 - See **PARTS INFORMATION** on page 4.
 - **DO NOT** replace the complete main muffler assembly for this incident, if it should occur.
2. Erase the DTC.

IMPORTANT: The purpose of **ACTION** (above) is to give you a quick idea of the work you will be performing. You **MUST** closely follow the entire **SERVICE PROCEDURE** as it contains information that is essential to successfully completing this repair.

Nissan Bulletins are intended for use by qualified technicians, not 'do-it-yourselfers'. Qualified technicians are properly trained individuals who have the equipment, tools, safety instruction, and know-how to do a job properly and safely. **NOTE:** If you believe that a described condition may apply to a particular vehicle, **DO NOT** assume that it does. See your Nissan dealer to determine if this applies to your vehicle.

SERVICE PROCEDURE

1. Remove the main muffler assembly (see Figure 1).
 - For main muffler assembly removal, refer to the Electronic Service Manual (ESM). Type “exhaust system” in the **Title Search** box, and then select the [Removal and Installation \(GT-R certified NISSAN dealer\)](#) link to the right of **TITANIUM MUFFLER**.

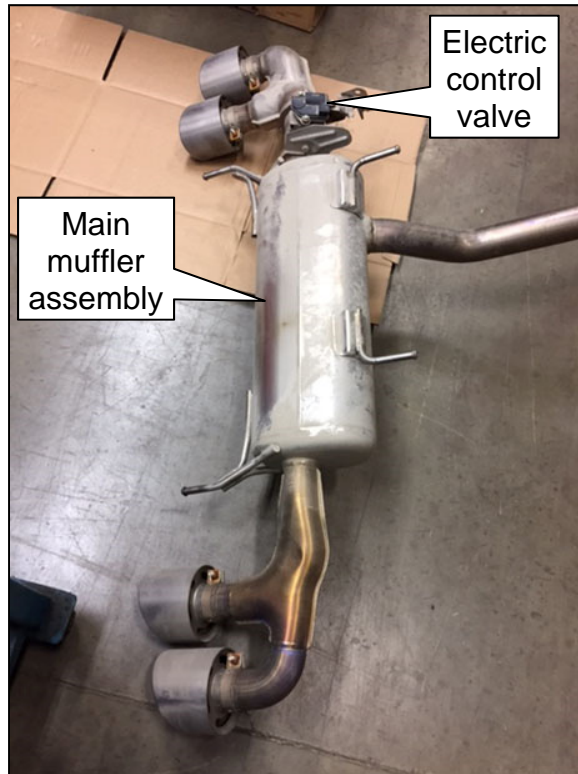

Figure 1

2. Remove the four (4) nuts and bolts, and then remove the electric control valve.

NOTE:

- Two of the nuts and bolts are hidden in Figure 2.
- The electric control valve is also called “electric control muffler” in the ESM.

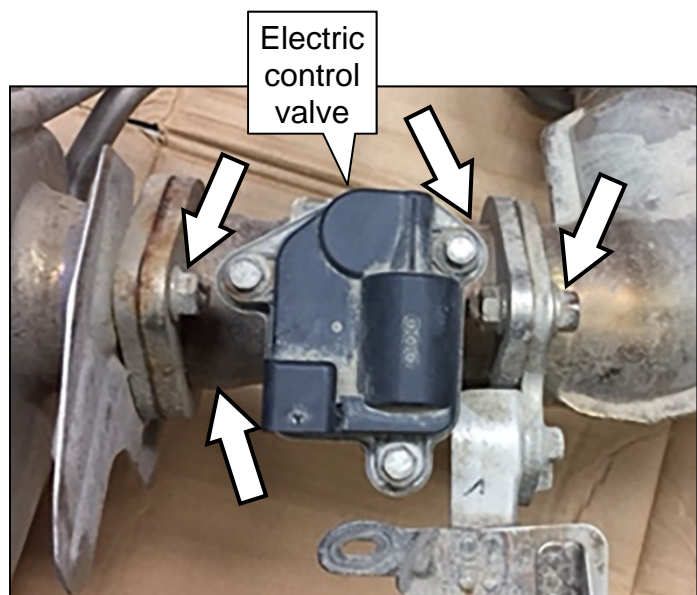

Figure 2

NOTE: The nuts and bolts are secured by a small weld. Twist off the nuts to break the welds (see Figure 3).



Figure 3

3. Install the new electric control valve to the main muffler assembly with new nuts and bolts.
 - Use new gaskets (see **PARTS INFORMATION** on page 4). Do not reuse the old gaskets.
 - For electric control valve installation, refer to the ESM. Type “exhaust system” in the **Title Search** box, and then select the [Exploded View](#) link to the right of **TITANIUM MUFFLER**.

NOTE: The nuts and bolts need only to be torqued. They do not need to be welded after torquing. Torque values are in the ESM where outlined above.

4. Reinstall the main muffler assembly.
 - Use new gaskets (see **PARTS INFORMATION** on page 4). Do not reuse old gaskets.
 - For main muffler assembly installation, refer to the ESM. Type “exhaust system” in the **Title Search** box, and then select the [Removal and Installation \(GT-R certified NISSAN dealer\)](#) link to the right of **TITANIUM MUFFLER**.

PARTS INFORMATION

DESCRIPTION	PART NUMBER	QUANTITY
VALVE ASSEMBLY-EXHAUST (electric control valve)	20150-6AV0A	1
GASKET (both ends of electric control valve)	20692-JF00B	2
BOLT (both ends of electric control valve)	20606-6AV0A	4
NUT-FIX, EXHAUST TUBE (both ends of electric control valve)	20602-6AV0A	4
GASKET-EXHAUST (main muffler to sub muffler)	20692-JF00A	1
NUT-FLANGE, HEX (main muffler to sub muffler)	08918-3401A	2
GASKET-EXHAUST (three way catalyst to sub muffler gasket)	20692-24U00	2
NUT-FIX, EXHAUST TUBE (three way catalyst to sub muffler)	20602-41G0A	4

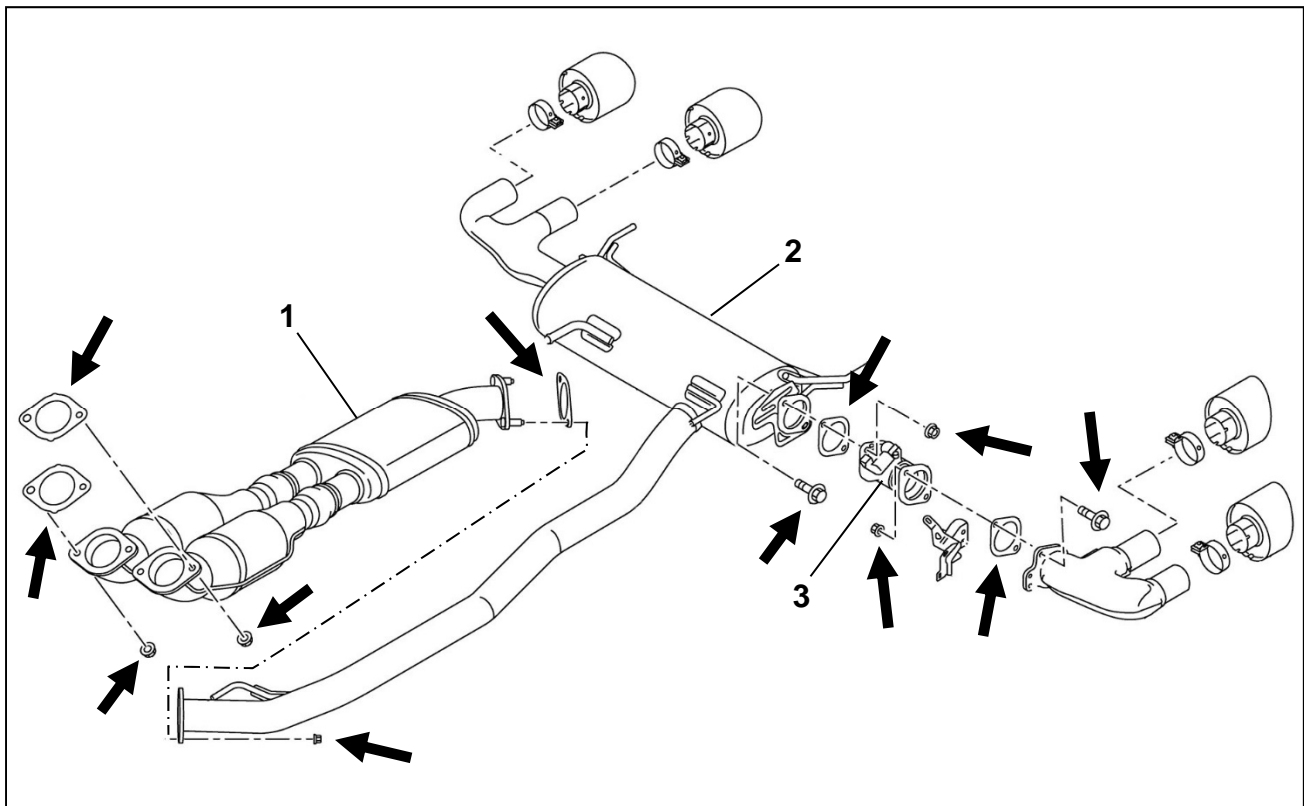

Figure 4

1. Sub muffler 2. Main muffler assembly 3. Electric control muffler

CLAIMS INFORMATION

Submit a Primary Part (PP) type line claim using the following claims coding:

DESCRIPTION	PFP	OP CODE	SYM	DIA	FRT
RPL Electric Control Valve	(1)	FD94AA	HC	32	(2) (3)

- (1) Reference the Electronic Parts Catalog and use the Electric Control Valve (20150-*****) as the Primary Failed Part (PFP).
- (2) Reference the current Nissan Warranty Flat Rate Manual and use the indicated Flat Rate Time (FRT).
- (3) FRT allows adequate time to access DTC codes. No other diagnostic procedures subsequently required. Do NOT claim any Diagnostic Op Codes with this claim.

AMENDMENT HISTORY

PUBLISHED DATE	REFERENCE	DESCRIPTION
April 24, 2019	NTB19-036	Original bulletin published
February 3, 2021	NTB19-036a	CLAIMS INFORMATION revised

