

Technical product information

Topic	Bentayga V8 Kovomo - DTC P310B00 with Symptom Code 2638 - Check Engine Lamp - Fuel Pressure Regulation
Market area	Bentley: worldwide (2WBE)
Brand	Bentley
Transaction No.	2058484/5
Level	EH
Status	Approval
Release date	

New customer code

Object of complaint	Complaint type	Position
information, navigation, communication, entertainment -> symbolic fault indicators -> fault indicator for fuel system	functionality -> activates	
information, navigation, communication, entertainment -> symbolic fault indicators -> emission control system fault indicator	functionality -> activates	

New workshop code

Object of complaint	Complaint type	Position
engine -> fuel supply -> low-pressure fuel pump (tank)	functionality -> uneven	
engine -> operation, engine control -> engine control unit	functionality -> misfire	
engine -> operation, engine control -> engine control unit	electrics -> ground connection damaged	
engine -> operation, engine control -> engine control unit	control units, services -> with event log entry	
engine -> operation, engine control -> engine control unit	control units, services -> measured value too high	
engine -> operation, engine control -> engine control unit	control units, services -> error message	

Vehicle data

Bentayga - V8 Kovomo

Sales types

Type	MY	Brand	Designation	Engine code	Gearbox code	Final drive code
4V14D9	2018	E		*	*	*
4V14D9	2019	E		*	*	*
4V14D9	2020	E		*	*	*
4V14D9	2021	E		*	*	*

Documents

Document name
master.xml

Customer statement / workshop findings

Check Engine Lamp illuminated within the Driver Instrument Panel (DIP) in conjunction with the DTC as detailed below:

- “P310B00 with symptom code 2638 - Low Fuel Pressure Regulation”

There may be multiple DTC's and symptoms present due to fuel pressure regulation or fuel supply issues

Technical background

In the event the customer complaint relates to the following:

- Customer experienced poor start up or the engine stalled shortly after start up – proceed with the remaining instructions

NOTE: The operative must gather information regarding the Customer experience regarding when the issue occurred for example: Pre-conditions, warning lights and driveability at time issue occurred, details when the vehicle was last refuelled and the grade of fuel used

The operative must now use the information contained within the “Measure” section to determine the correct analysis and repair procedure.

Production change

Not applicable.

Measure

Check Engine Lamp Illumination with DTC P310B00 and symptom code 2638

1) For vehicles that only have the symptoms:

- Check Engine Lamp Illumination with DTC “P310B00 and symptom code 2638 with an “Adaption of Fuel Pump (FP)” figure of minus 100 to minus 200 kPa – Figure 1 - the Fuel Delivery Module within the fuel tank should be replaced – Figure 2

- Refer to Repair Group 20 Fuel supply, gas operation / 4.0L V8 TSI / Fuel pump, fuel level sensors, and jet pump (RH) – To remove and fit.

To check the “Adaption of Fuel Pump (FP)” figure within the fault memory, refer to Engine control Unit “01 – Engine Control Module 1” - From “Extended ambient conditions” note the value of the “Adaption of Fuel Pump (FP)” – Figure 1.

Initial system test with fault memory entries

Address: 0001 System name: 01 - Engine Control Module 1 Protocol variant: UDS/ISOTP (Ereignisse: 1)

+ Identification:

- Event memory entries (Data source: Vehicle):

Entry in fault memory

Number: P310B00: Low Fuel Pressure regulation Fuel pressure outside specification
 Fault type 2: passive/sporadic
 Symptom: **2638**
 Status: 10101000

- Standard ambient conditions:

Date: 05/11/19
 Time: 09:52:18
 Mileage (DTC): 92
 Priority: 2
 Frequency counter: 8
 Unlearning counter / driving cycle: 255

- Extended ambient conditions:

Engine speed 602.0 1/min
 Normed load value 7.05882366 %
 Vehicle speed 0 km/h
 Coolant temperature 73 °C
 Intake air temperature 15 °C
 Ambient air pressure 1010 mbar
 Voltage terminal 30 14.92 V
 Dynamic environmental data 20 96 28 11 CE 11 94 11 C8 11 AE 11 C9
 F9 E4 11 A4 26 66 12 8A A2 15 9F 44 D4
 15 A0 44 A4
 Unlearning counter according OBD 40
 Low fuel pressure, specified value 450.0 kPa
 Fuel low pressure, actual value 452.6 kPa
Adaptation of Fuel Pump (FP) -156.4 kPa
 Fuel pump, specified value 14.9999 %
 Fuel temperature 73.5 °C
 Fuel high pressure, actual value 8.81 MPa
 Fuel pressure rail 2 8.786 MPa

Figure 1

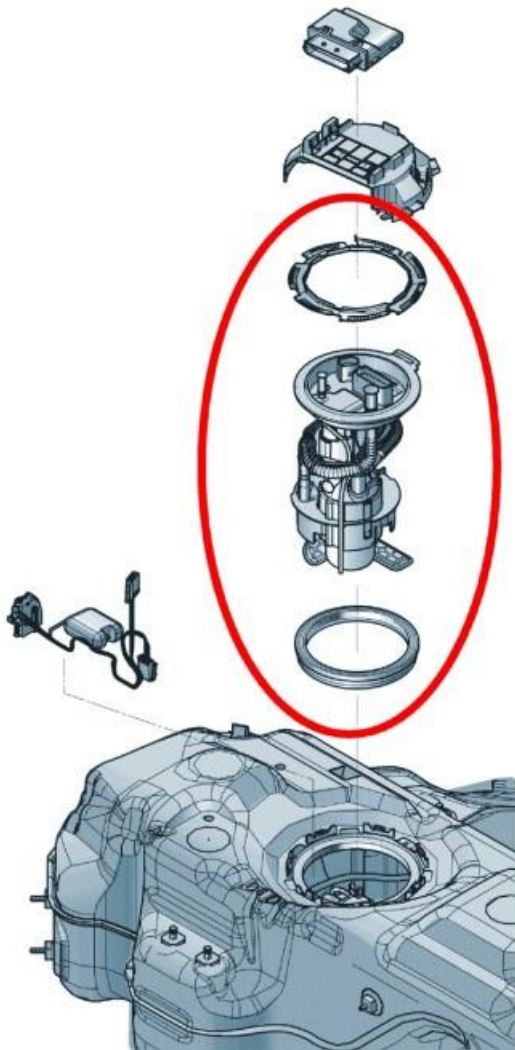

Figure 2

Warranty accounting instructions

Time to replace the Fuel delivery module

Warranty type – 110 or 910

Damage Service Number 20 66

Damage Code 00 10

Labour

Labour Operation Code 20 66 19 50

Time 50 TU

Time to replace the fuel pump control unit (J538)

Labour Operation Code 20 70 19 50

Time 10 TU

Time to remove and refit the rear seats (4 seat)

Labour Operation Code 68 16 19 01

Time 190 TU

Time to remove and refit the rear seats (5 seat)

Labour Operation Code 72 48 20 05

Time 100 TU

Time to remove and refit the seat sill panel

Labour Operation Code 68 05 19 00

Time 20 TU

Time to remove and refit the boot side trim panel

Labour Operation Code 70 03 19 00

Time 40TU

[Parts information](#)

For the latest part information always refer to the Electronic Parts Catalogue – ETKA.