

# Technical product information

<b>Topic</b>	Bentayga V8 Kovomo - DTC P304300 with symptom code (10061) - Fuel Pump Mechanical Malfunction - MIL lamp
<b>Market area</b>	Russische Föderation (5RU),Australia E04 Bentley rest Asia and Australia (6E04),China 796 VW Import Comp. Ltd (Vico), Beijing (6796),Germany E02 Bentley rest Europe (6E02),Japan E03 Bentley Japan (6E03),Korea, (South) E08 Bentley South Korea (6E08),United Arab Emirates E06 Bentley Middle East and Africa (6E06),United Kingdom E01 Bentley UK (6E01),United States E05 Bentley USA and rest America (6E05)
<b>Brand</b>	Bentley
<b>Transaction No.</b>	2062092/1
<b>Level</b>	EH
<b>Status</b>	Approval
<b>Release date</b>	

## Event memory entries

Diagnostic address	Event memory entry	Fault type	Fault status
0001 - Engine electronics	P304300: Fuel pump Mechanical malfunction		Intermittent
0001 - Engine electronics	P304300: Fuel pump Mechanical malfunction		static

## New customer code

Object of complaint	Complaint type	Position
information, navigation, communication, entertainment -> symbolic fault indicators -> fault indicator for fuel system	functionality -> activates	
information, navigation, communication, entertainment -> symbolic fault indicators -> emission control system fault indicator	functionality -> activates	

## New workshop code

Object of complaint	Complaint type	Position
engine -> fuel supply -> low-pressure fuel pump (tank)	functionality -> uneven	
engine -> operation, engine control -> engine control unit	functionality -> misfire	
engine -> operation, engine control -> engine control unit	electrics -> ground connection damaged	
engine -> operation, engine control -> engine control unit	control units, services -> with event log entry	
engine -> operation, engine control -> engine control unit	control units, services -> error message	

# Vehicle data

## Bentayga - V8 Kovomo

### Sales types

Type	MY	Brand	Designation	Engine code	Gearbox code	Final drive code
4V14D9	2018	E		*	*	*
4V14D9	2019	E		*	*	*
4V14D9	2020	E		*	*	*
4V14D9	2021	E		*	*	*

# Documents

Document name
<a href="#">master.xml</a>

## Customer statement / workshop findings

### Customer statement

Check Engine Lamp illuminated within the Driver Instrument Panel (DIP)

### Workshop findings

DTC P304300 – with symptom code (10061) - Fuel Pump Mechanical Malfunction evident

## Technical background

Refer to the Measure section of this TPI

## Production change

Not applicable.

## Measure

1) Inspect the underbody fuel lines for any of the following potential issues:

- Kinks
- Cracks
- Poor fitment
- Loose fitment
- Distortion

2) Check and confirm the low pressure fuel system is operating to specification - Refer to Rep.Gr20 - Low pressure fuel system – To test

3) Referring to Rep.Gr20 gain access to the fuel pump control unit (J538) - Check the fuel pump control unit connector for damage and/or corrosion

4) Conduct a visual inspection of the fuel pump delivery module (Top) for any obvious signs of damage (Figure 1)

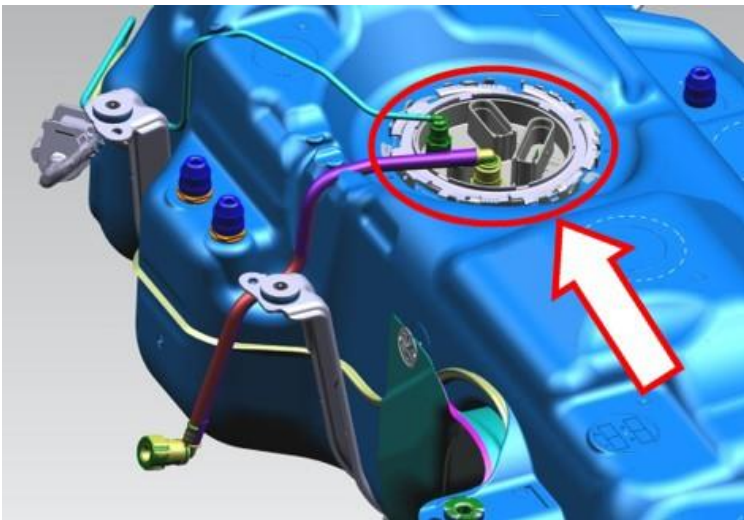

Figure 1

5) Should all the advised checks detailed in steps 1 to 4 be to specification – Replace the Fuel Delivery Module within the fuel tank (Figure 2) - Refer to Repair Group 20 Fuel supply, gas operation / 4.0L V8 TSI / Fuel pump, fuel level sensors, and jet pump (RH) – To remove and fit

6) Check inside the fuel tank for any signs of debris

▪ In the event that debris is found within the fuel tank the operative should refer to the onward instructions regarding debris:

- Attach clear photos of the debris within the tank to a new or existing DISS query
- The debris should be collected from the tank and stored safely in a sealed container as it may be requested for analysis

7) Replace the fuel pump control unit (J538) – Rep.Gr20

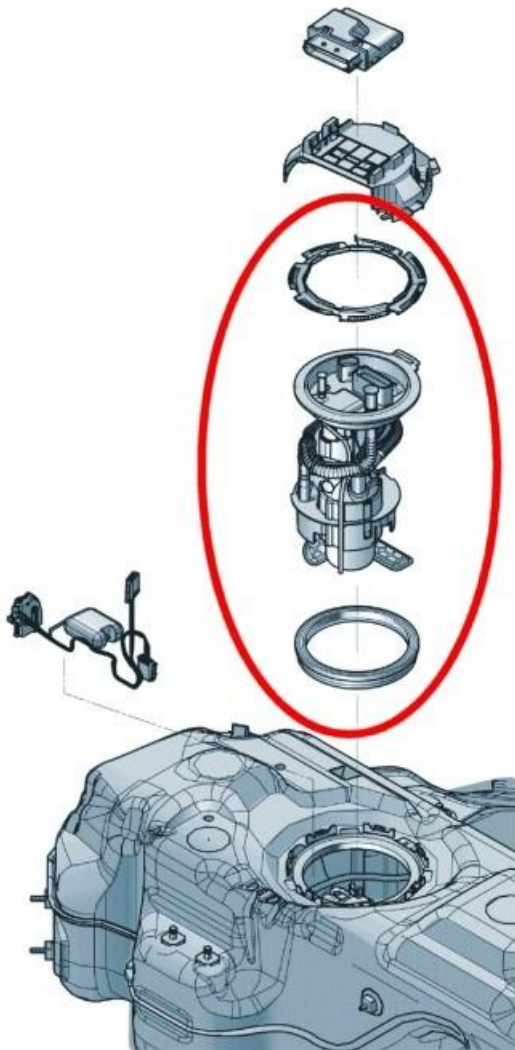

Figure 2

Warranty accounting instructions

Time to replace the Fuel delivery module

Warranty type – 110 or 910

Damage Service Number 20 66

Damage Code 00 10

Labour

Labour Operation Code 20 66 19 50

Time 50 TU

Time to replace the fuel pump control unit ( J538)

Labour Operation Code 20 70 19 50

Time 10 TU

Time to remove and refit the rear seats ( 4 seat)

Labour Operation Code 68 16 19 01

Time 190 TU

Time to remove and refit the rear seats ( 5 seat)

Labour Operation Code 72 48 20 05

Time 100 TU

Time to remove and refit the seat sill panel

Labour Operation Code 68 05 19 00

Time 20 TU

Time to remove and refit the boot side trim panel

Labour Operation Code 70 03 19 00

Time 40TU

### Self Diagnosis

Labour Operation Code 01 50 00 00

Time Time taken from diagnostic log (Maximum 30TU)

### Parts information

For the latest part information always refer to the Electronic Parts Catalogue – ETKA.