

**New CNG Tailgate Streetside and Curbside Panel and Door Installation**

**Date:** February 5, 2021

**Bulletin Name:** MISC-TSIB-077

**Models:** Meridian, Atlantic, Zero Radius

**Model Year:** 2018 to present (to newest tailgate shape with the flat upper panel)

**Units Affected:** Those with CNG tailgate

**Purpose:**

McNeilus Truck and Manufacturing offers these instructions for the installation of a new streetside cover panel with thumb latch on the doors and a new curbside cover panel with doors (having doors on panel is a new feature for the curbside cover panel) on compressed national gas (CNG) tailgate units. By installing these new cover panels, technicians will easily be able to gain access to inspect the CNG tanks by using thumb latches on the streetside and the new doors on the curbside of the unit.

**Notice:**

- This bulletin should be read and understood in its entirety before performing this procedure.
- All procedures outlined in the bulletin must be performed by skilled service personnel. Refer to the product service manual for descriptions of maintenance procedures.
- Procedures are separated by side of truck. Complete one or both installation instructions as needed.

**SAFETY NOTICE**

**Perform your company's Lockout/Tagout procedure. If your company does not have a Lockout/Tagout procedure, follow OSHA 1910.147 and 1910.146 Confined Space as appropriate.**

**SAFETY NOTICE**

**Use appropriate Personal Protective Equipment (PPE) as required by your company.**

**Procedure Street Side Installation:**

**Tools and Equipment Required:**

Customer to supply:

- Wrenches
- Torque wrenches
- Reference torque specifications in truck’s service manual

**Parts Required:**

Item	PN	Description	Qty.
1	1616310	COVER PANEL, CNG, TG, EX, SIDE, LH, HV	1
2	1616309	DOOR COVER, CNG, VALVE, ACCESS, HV	3
3	1616307	DOOR COVER, SMALL, CNG, VALVE, ACCESS, HV	1
4	1426486	LATCH, PUSH BUTTON COMPRESSION	4

1. Perform your company’s Lockout/Tagout (LOTO) procedure. If your company does not have a Lockout/Tagout procedure, follow OSHA 1910.147 and 1910.146 Confined Space as appropriate. Apply wheel chocks, enable the parking brake.
2. Unfasten the existing doors from the existing side cover panel on the street side. Retain the hinges, flange bolts, and flange lock nuts (Figure 1); discard the quarter turn wing head and wing head receptacle.

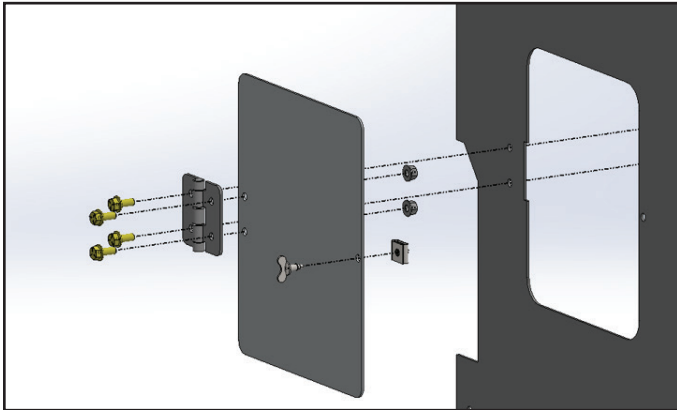

Figure 1 Unfasten existing doors and hardware from existing side cover.

3. Assemble the new doors on to the **new** side cover panel (Figure 2). These procedures are using new doors and new cover panels.

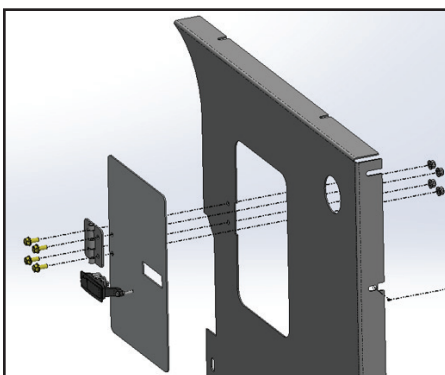

Figure 2 Install new doors (with new thumb latch) using existing hinges, bolts, and lock nuts.



4. Remove and retain exterior fasteners that secure the old cover panel to the tailgate (as shown in Figure 3 forward side, Figure 4 top, and Figure 5 rear side).

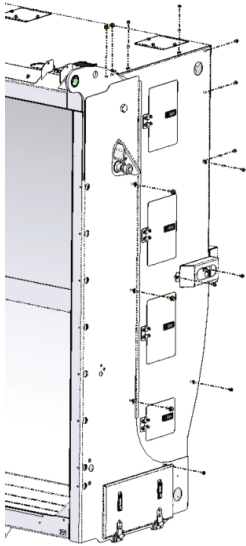

Figure 3

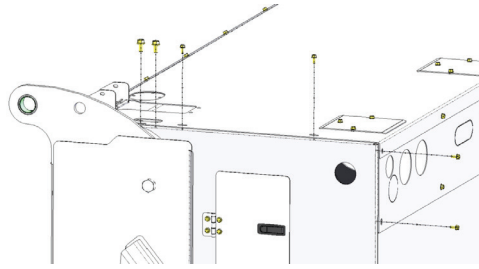

Figure 4

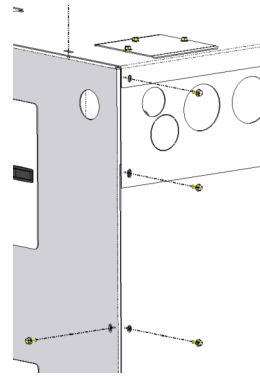

Figure 5

5. If side bracket for light bar exists, first remove the exterior bolt on the right to then gain access to the interior bolt on the left (Figure 6). Remove light housing. Retain all components.
6. Remove and retain exterior fasteners that secure the old cover panel to the tailgate (Figure 6 side view).

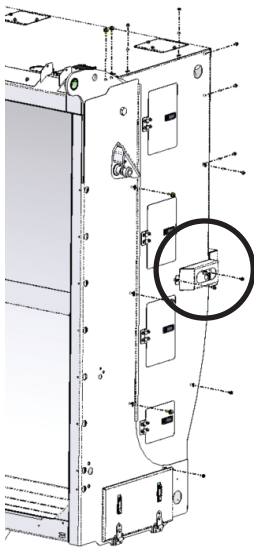

Figure 6

7. Confirm a total of 15 bolts have been removed and retained to allow the side cover panel to detach from the tailgate.
- 5/16" flange bolts = quantity 13
  - 3/8" flange bolts = quantity 2
8. Remove the side cover panel and discard.
9. Using the retained fasteners, fasten the new side cover panel to the tailgate exactly like the previous side cover panel. Torque fasteners.

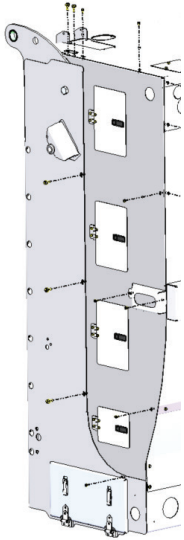

Figure 7

10. If curbside cover panel installation is required, continue with next procedure and do not remove Lockout/Tagout yet.
11. Remove your company's Lockout/Tagout procedure. If your company does not have a Lockout/Tagout procedure, follow OSHA 1910.147 and 1910.146 Confined Space as appropriate. Remove wheel chocks, Disengage the parking brake.

**Procedure Curb Side Installation:**

**Tools and Equipment Required:**

Customer to supply:

- Wrenches
- Torque wrenches
- Reference torque specifications in truck's service manual

**Parts Required:**

Item	PN	Description	Qty.
1	1616311	COVER PANEL, CNG, TG, SIDE, RH, HV	1
2	1616348	DOOR COVER, CNG, TANK VIEW, HV	3
3	1616350	DOOR COVER, SMALL, CNG, TANK VIEW, HV	1
4	1469068	NUT, SPRING .31-18, .025-.150, PNL	4
5	1241613	SCR, FLG, HEX .31-18 X .75 G5 ZY	16
6	0120199	NUT, FLG, LKDT .31-18 GG CW	16
7	1426062	HINGE, 3.00 X 3.00, ALUM	4

1. Perform your company's Lockout/Tagout procedure. If your company does not have a Lockout/Tagout procedure, follow OSHA 1910.147 and 1910.146 Confined Space as appropriate. Apply wheel chocks, enable the parking brake.
2. Assemble the new doors on to the **new** side cover panel using hinges, flange bolts, flange lock nuts and install the new spring nut.

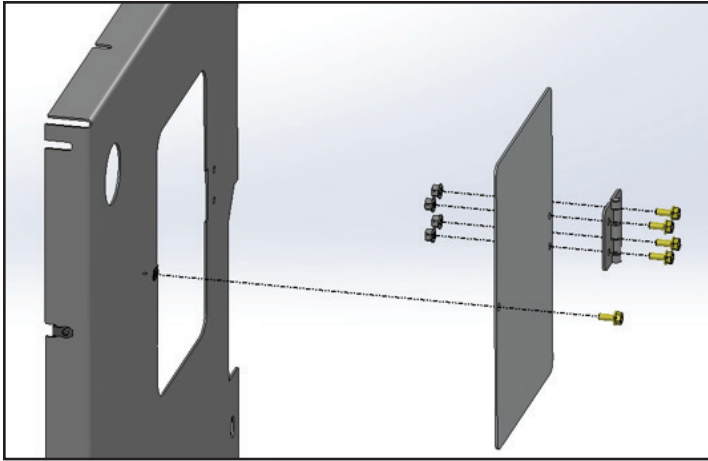

Figure 8



PN 1616348 X 3

PN 1616350 X 1

3. Remove and retain exterior fasteners that secure the old cover panel to the tailgate (as shown in Figure 9. Some fasteners on top, forward, rearward).

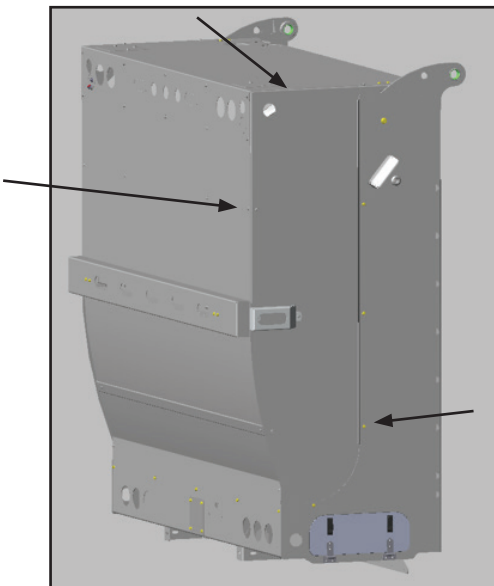

Figure 9

4. If side bracket for light bar exists, first remove the exterior bolt on the right to then gain access to the interior bolt on the left (Figure 10). Remove light housing. Retain all components.
5. Remove and retain exterior fasteners that secure the old cover panel to the tailgate (Figure 10 side view as shown for illustrative purposes only).

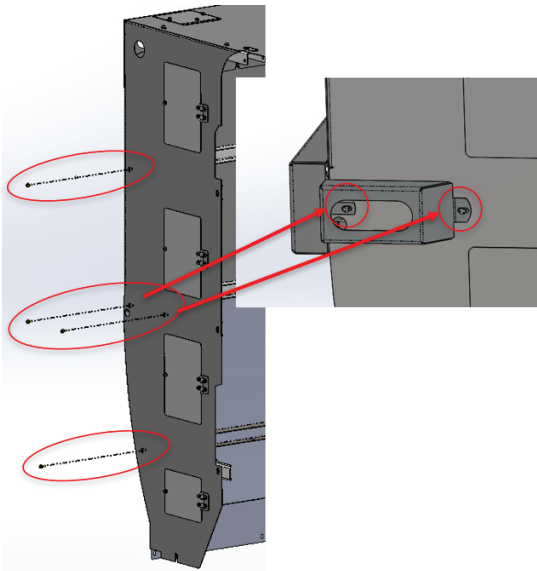

Figure 10

6. Confirm a total of 15 bolts have been removed and retained to allow the side cover panel to detach from the tailgate.
  - 5/16" flange bolts = quantity 13
  - 3/8" flange bolts = quantity 2
7. Remove the side cover panel and discard.
8. Using the retained fasteners, fasten the new side cover panel to the tailgate exactly like the previous side cover panel. Torque fasteners.

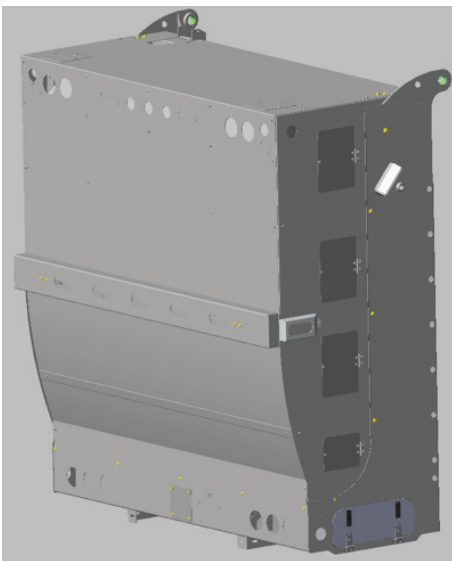

Figure 11

9. Remove your company's Lockout/Tagout procedure. If your company does not have a Lockout/Tagout procedure, follow OSHA 1910.147 and 1910.146 Confined Space as appropriate. Remove wheel chocks, Disengage the parking brake.



(888) 686-7278

[www.streetsmartparts.com](http://www.streetsmartparts.com)