

Subject: CHECK ENGINE LIGHT ON WITH DTC P0524 OR P055F	Bulletin No.: 01-004/21
	Last Issued: 02/05/2021

APPLICABLE MODEL(S)/VINS

2018-2020 CX-5 2.5L (with cylinder deactivation) vehicles with VINs lower than JM3KF*****869654 (produced before Aug. 24, 2020)

2021 CX-5 2.5L (with cylinder deactivation and 8" center display) vehicles with VINs lower than JM3KF*****120983 (produced before Dec. 14, 2020)

2021 CX-5 2.5L (with cylinder deactivation and 10.5" center display) vehicles with VINs lower than JM3KF*****358113 (produced before Dec. 14, 2020)

DESCRIPTION

Some vehicles may have the check engine light on with DTC P0524:00 or P055F:00 stored in memory. Contamination in the engine oil may cause the engine oil solenoid valve to become stuck, resulting in improper operation of the oil pump and improper oil pressure.

- DTC P0524:00 (Engine oil pressure too low)
- DTC P055F:00 (Engine oil pressure malfunction)

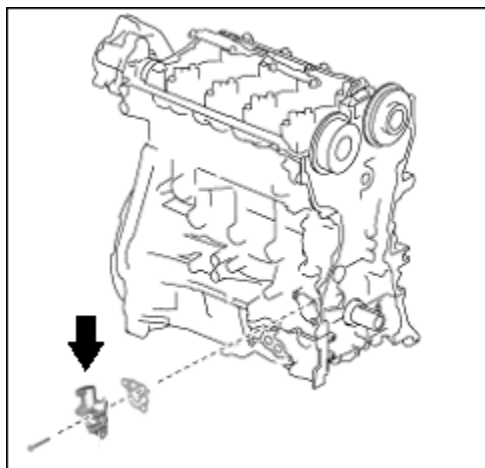

CONSUMER NOTICE: The information and instructions in this bulletin are intended for use by skilled technicians. Mazda technicians utilize the proper tools/equipment and take training to correctly and safely maintain Mazda vehicles. These instructions should not be performed by "do-it-yourselfers." Customers should not assume this bulletin applies to their vehicle or that their vehicle will develop the described concern. To determine if the information applies, customers should contact their nearest authorized Mazda dealership. Mazda North American Operations reserves the right to alter the specifications and contents of this bulletin without obligation or advance notice. All rights reserved. No part of this bulletin may be reproduced in any form or by any means, electronic or mechanical---including photocopying and recording and the use of any kind of information storage and retrieval system ---without permission in writing.

The control software of the PCM has been modified to eliminate this concern. In addition, the production process has been modified to reduce contamination in the engine oil solenoid valve, oil pump, spacer and oil filter.

Customers having this concern should have their vehicle repaired using the following repair procedure.

REPAIR PROCEDURE

1. Verify the customer concern.
2. Replace the engine oil solenoid valve with a new one according to MGSS online (ENGINE OIL SOLENOID VALVE REMOVAL/INSTALLATION [SKYACTIV-G 2.5 (WITH CYLINDER DEACTIVATION)]).
3. Replace the engine oil and engine oil filter.
4. Reprogram the PCM with Mazda Modular Diagnostic System (M-MDS) using IDS software according to IDS PCM REPROGRAMMING PROCEDURE.
5. Verify the repair.

CALIBRATION INFORMATION

MY	Drive	File Name	Note
2018	2WD	PYFA-188K2-L	Mitsubishi
		PYFB-188K2-L	Denso
	4WD	PYFC-188K2-L	Mitsubishi
		PYFD-188K2-L	Denso
2019	2WD	PX42-188K2-E	Mitsubishi
		PX43-188K2-E	Denso
	4WD	PX44-188K2-F	Mitsubishi
		PX45-188K2-F	Denso
2020 and 2021	2WD	PX2E-188K2-E	Mitsubishi
		PX2F-188K2-E	Denso
	4WD	PX2G-188K2-E	Mitsubishi
		PX2H-188K2-E	Denso

CONSUMER NOTICE: The information and instructions in this bulletin are intended for use by skilled technicians. Mazda technicians utilize the proper tools/equipment and take training to correctly and safely maintain Mazda vehicles. These instructions should not be performed by "do-it-yourselfers." Customers should not assume this bulletin applies to their vehicle or that their vehicle will develop the described concern. To determine if the information applies, customers should contact their nearest authorized Mazda dealership. Mazda North American Operations reserves the right to alter the specifications and contents of this bulletin without obligation or advance notice. All rights reserved. No part of this bulletin may be reproduced in any form or by any means, electronic or mechanical---including photocopying and recording and the use of any kind of information storage and retrieval system ---without permission in writing.

PARTS INFORMATION

Parts Number	Description	Qty.	Notes
PYFA-14-440C	VALVE,OIL CONTROL	1	
PY8W-14-365	GASKET	1	[R]
PY8W-14-275	BOLT	3	[R]
1WPE-14-302	CARTRIDGE,OIL FILTER	1	

[R]: Replacement parts

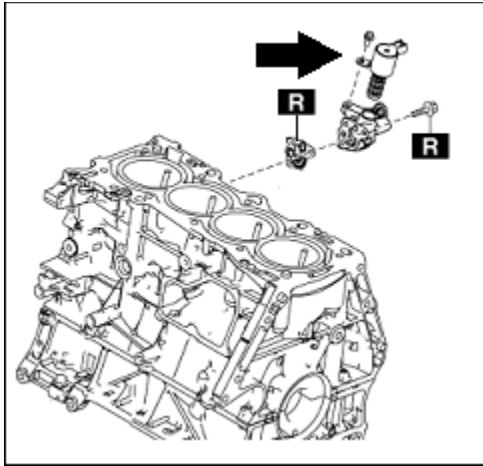

WARRANTY INFORMATION

NOTE:

- This warranty information applies only to verified customer complaints on vehicles eligible for warranty repair.
 - This repair will be covered under Mazda’s New Vehicle Fed. Emission Warranty, Calif. Emission Warranty (short term).
 - Additional diagnostic time cannot be claimed for this repair.

Warranty Type	A
Symptom Code	6X
Damage Code	9W
Part Number Main Cause	5555-RP-PCM

CONSUMER NOTICE: The information and instructions in this bulletin are intended for use by skilled technicians. Mazda technicians utilize the proper tools/equipment and take training to correctly and safely maintain Mazda vehicles. These instructions should not be performed by “do-it-yourselfers.” Customers should not assume this bulletin applies to their vehicle or that their vehicle will develop the described concern. To determine if the information applies, customers should contact their nearest authorized Mazda dealership. Mazda North American Operations reserves the right to alter the specifications and contents of this bulletin without obligation or advance notice. All rights reserved. No part of this bulletin may be reproduced in any form or by any means, electronic or mechanical---including photocopying and recording and the use of any kind of information storage and retrieval system ---without permission in writing.

Quantity	0
Operation Number / Labor Hours:	XXT19XFX / 0.8 Hrs.

NOTE: Claim the parts and engine oil as related parts.

CONSUMER NOTICE: The information and instructions in this bulletin are intended for use by skilled technicians. Mazda technicians utilize the proper tools/equipment and take training to correctly and safely maintain Mazda vehicles. These instructions should not be performed by "do-it-yourselfers." Customers should not assume this bulletin applies to their vehicle or that their vehicle will develop the described concern. To determine if the information applies, customers should contact their nearest authorized Mazda dealership. Mazda North American Operations reserves the right to alter the specifications and contents of this bulletin without obligation or advance notice. All rights reserved. No part of this bulletin may be reproduced in any form or by any means, electronic or mechanical---including photocopying and recording and the use of any kind of information storage and retrieval system ---without permission in writing.