



FIELD SERVICE CAMPAIGN – 21102

19 February 2021

SUBJECT:

Replacement of Air Cleaner Filter Elements

MODELS INVOLVED:

International® LoneStar® Series

DEFECT DESCRIPTION:

Certain International® LoneStar® Series trucks built 01 October 2019 through 24 October 2020 may have air filter elements that can debond resulting in dirt entering the engine intake.

ELIGIBILITY:

This procedure applies ONLY to vehicles marked in the International® Service PortalSM with FSC 21102. Also complete any other open campaigns listed on the Service Portal at this time.

TOOLS REQUIRED:

No special tools are required.

PARTS REQUIRED:

Part Number	Description	Quantity
2599273C92	Kit Filter Elements Driver-Side / Passenger-Side	1

Table 1 Parts Information

WORK INSTRUCTIONS

WARNING! To prevent personal injury and / or death, or damage to property, park vehicle on hard flat surface, turn the engine off, set the parking brake, and install wheel chocks to prevent the vehicle from moving in both directions.

WARNING! To prevent personal injury and / or death, always wear safe eye protection when performing vehicle maintenance.

WARNING! To prevent personal injury and / or death, or damage to property, keep flames or sparks away from vehicle and do not smoke while servicing the vehicle's batteries. Batteries expel explosive gases.

1. Park vehicle on flat surface.
2. Shift transmission into Park or Neutral and set parking brake.
3. Turn ignition to Key OFF position.
4. Install wheel chocks.

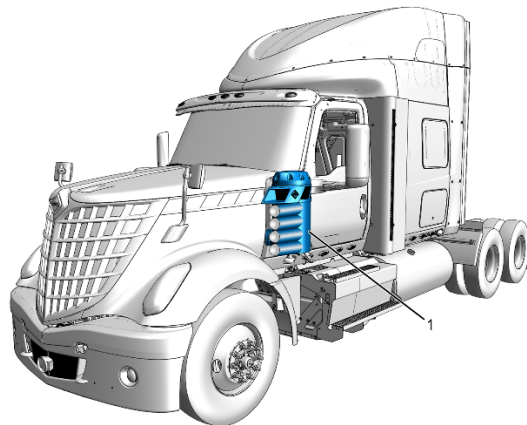

0000428338

Figure 1: Air Cleaner Location

1. Air cleaner (driver-side)

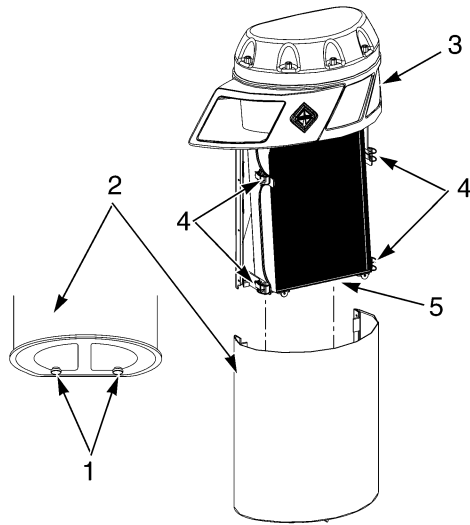

3817038

Figure 2: Air Filter Element Service

1. Thumb screw (2)
2. Filter element cover
3. Air cleaner housing
4. Latch (2)
5. Filter element

NOTE: LoneStar® Series trucks are equipped with air cleaner housings on each side of cowl: driver-side (Figure 1, Item 1) and passenger-side.

NOTE: Thumb screws (Figure 2, Item 1) are attached to air cleaner housing (Figure 2, Item 3) with retainer washers and cannot be removed from housing.

CAUTION! To prevent damage to property, be careful not to jostle filter as it is removed from housing. Doing so may cause dust and debris to enter turbocharger piping.

5. Remove driver-side air cleaner housing (Figure 2, Item 3). Loosen thumb screws (Figure 2, Item 1) located on bottom of air cleaner housing.
6. Remove filter element cover (Figure 2, Item 2) by sliding filter element cover down and off the air cleaner housing (Figure 2, Item 3).

7. Unhook latches (Figure 2, Item 4) from filter element (Figure 2, Item 5). Remove filter element by pulling bottom of filter element away and down from air cleaner housing (Figure 2, Item 3).

CAUTION! To prevent damage to property, DO NOT USE compressed air to clean air cleaner housing.

8. Wipe inside of air cleaner housing and port going to engine with a clean damp cloth.
9. Install new filter element (Figure 2, Item 5) into air cleaner housing (Figure 2, Item 3). Make sure that filter element seats squarely in housing. Secure filter element using latches (Figure 2, Item 4).
10. Install filter element cover (Figure 2, Item 2) onto air cleaner housing (Figure 2, Item 3) by starting at bottom of air cleaner housing and sliding notched sides of filter element cover up onto air cleaner housing. Secure filter element cover with thumb screws (Figure 2, Item 1).
11. Repeat Steps 5 – 10 for passenger-side air cleaner.
12. Remove wheel chocks.

LABOR INFORMATION

Operation number must appear on all claims.

Operation Number	Description	Time
A40-21102-1	Air Filter Replacement; Both Sides	0.3 hrs

Table 2 Labor Information

WARRANTY CLAIMS

Warranty claim expense is to be charged to Warranty. Claims are to be submitted in the normal manner, making reference to Field Service Campaign 21102.

Section 7 of the Warranty Policy and Procedures Manual contains further information related to the submission and processing of AFC / Recall claims.

As with all claim submissions, items acquired locally must be submitted in the “Other Charges” tab. The cost of any bulk items (such as a bag of cable tie straps, roll of wire, barrel of oil, or tube of silicone) should be prorated for the cost of the individual pieces / amount used during each repair.

To make sure this important improvement is made in a timely manner, all claims for 21102 activity must be submitted by 19 February 2022 or within the normal warranty period for the component repaired, if after 19 February 2022.

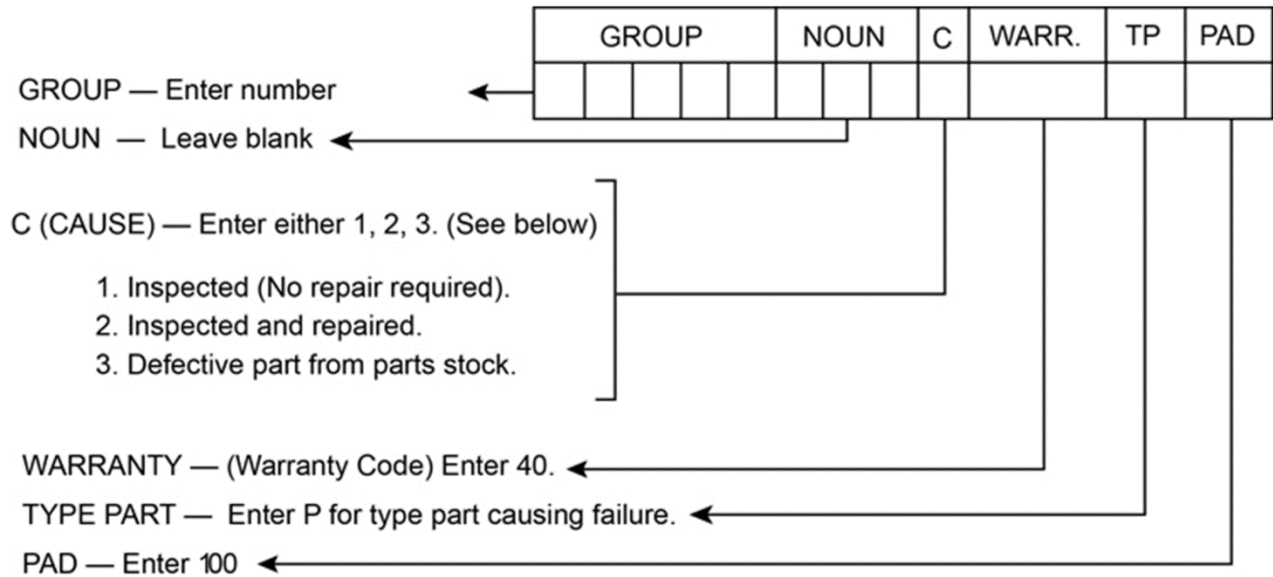

0000047910