

GLOBAL SAFETY FIELD INVESTIGATIONS
DCS5636
URGENT - DISTRIBUTE IMMEDIATELY

Date: January 5, 2021

Subject: N202320350 - Service Update
Lane Keep Assist Disable Harness Missing

Models: 2021 GMC Acadia
Equipped with Sensor Indicator – Forward Collision Alert (RPO UEU)

To: All General Motors Dealers

General Motors is releasing Service Update N202320350 today. The total number of U.S. vehicles involved is 23. Please see the attached bulletin for details.

Global Warranty Management (GWM)

The Required Field Action section on the Investigate Vehicle History (IVH) screen will be updated January 6, 2021 or sooner. A list of involved vehicles in dealer new inventory is attached to this message. Please hold all warranty transactions until IVH has been updated.

END OF MESSAGE
GLOBAL SAFETY FIELD INVESTIGATIONS

Service Update

N202320350 Lane Keep Assist Disable Harness Missing



Release Date: January 2021

Revision: 00

Attention: This service update includes vehicles in dealer inventory and customer vehicles that return to the dealership for any reason. This bulletin will expire at the end of the involved vehicle's New Vehicle Limited Warranty period.

Make	Model	Model Year		RPO	Description
		From	To		
GMC	Acadia	2021	2021	UEU	Sensor Indicator – Forward Collision Alert

Involved vehicles are marked "open" on the Investigate Vehicle History screen in GM Global Warranty Management system. This site should always be checked to confirm vehicle involvement prior to beginning any required inspections and/or repairs.

Condition	On certain 2021 model year GMC Acadia vehicles, the center consoles may have been assembled with harnesses missing two wires that connect the lane keep assist system to the disable switch. The lane keep assist will continue to be active and cannot be disabled.
Correction	Dealers are to inspect and if necessary, replace the front floor console wiring harness.

Parts

Quantity	Part Name	Part No.
1	HARNESS, F/FLR CNSL WRG	84810209

It is estimated that there are only 23 involved vehicles that will require parts being replaced. **Due to the small number of vehicles anticipated that will need this repair and the limited initial parts availability, dealers are encouraged not to order these parts for use as shelf stock.**

Reminder: Parts may be removed from Retail Inventory Management (RIM). Dealers should review the affected parts to confirm RIM managed status. Parts may have quantity limiters in effect.

Warranty Information

Labor Operation	Description	Labor Time	Trans. Type	Net Item
9105478	Verify Operation of Lane Assist Switch	0.2	ZFAT	N/A
9105472	Front Floor Console Wiring Harness Replacement	1.3	ZFAT	N/A

Service Update

N202320350 Lane Keep Assist Disable Harness Missing



Service Procedure

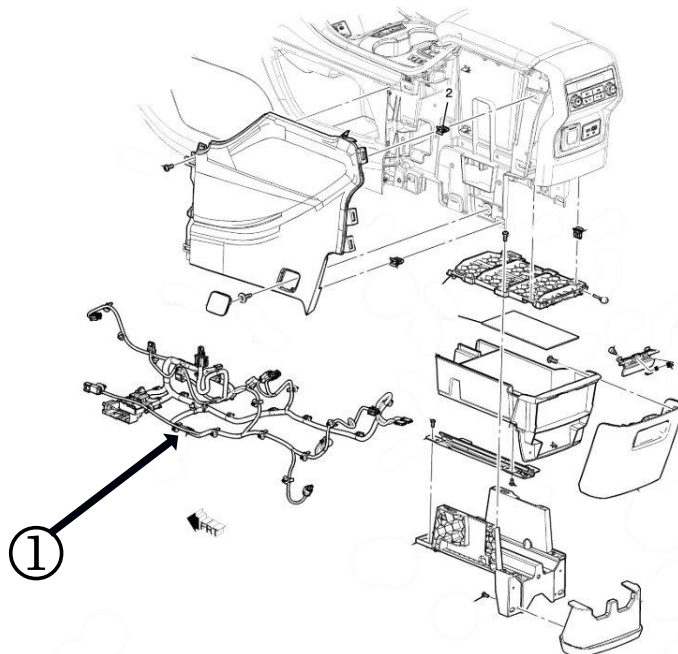

5682338

1. Verify the Lane Assist switch functions and can be turned off and on:
 - a. If the Lane Keep Assist switch functions correctly, no further action is required.
 - b. If the Lane Keep Assist switch does not turn the feature on and off, continue to step 2.
2. Replace the front floor console wiring harness (1). Refer to *Front Floor Console Removal and Installation* in SI.

Dealer Responsibility

Whenever a vehicle subject to this service update enters your vehicle inventory or is in your facility for service in the future, and the vehicle is still covered under the New Vehicle Limited Warranty, you must take the steps necessary to be sure the service update correction has been made before selling or releasing the vehicle.

All new, used, GM Certified Used, courtesy transportation vehicles, dealer shuttle vehicles, etc. in dealers' possession and subject to this bulletin must be held and inspected/repared per the service procedure of this bulletin before customers take possession of these vehicles. Involved vehicles must be held and not delivered to customers, dealer-traded, released to auction, used for demonstration, or any other purpose.

All GM Certified Used vehicles currently in the dealers' inventory within the Certified Pre-Owned Inventory System (CPOIS) will be de-certified and must be held and remedied per the service procedure in this bulletin. Upon submitting an accepted/paid warranty transaction in the Global Warranty Management (GWM) system, the vehicle can be re-certified for sale within the CPOIS system, or once again be used in the CTP program.

Dealer Reports

The Inventory tab of the Open Vehicle Report will contain Service Update Bulletin VINs that apply to this field action. This information is intended to assist dealers with the **PROMPT COMPLETION** of these vehicles. The Customer In-Service tab will not contain Service Update Bulletin VIN data because the intent of a Service Update Bulletin is to not inconvenience a customer with a special trip for service. Service Update Bulletins are to be completed when the customer is in for a regularly scheduled visit.

GM bulletins are intended for use by professional technicians, NOT a "do-it-yourselfer". They are written to inform these technicians of conditions that may occur on some vehicles, or to provide information that could assist in the proper service of a vehicle. Properly trained technicians have the tools, equipment, safety instructions, and know-how to do a job properly and safely. If a condition is described, **DO NOT** assume that the bulletin applies to your vehicle, or that your vehicle will have that condition. See your dealer for information on whether your vehicle may benefit from the information.



We Support
Voluntary Technician
Certification