



 HYUNDAI Technical Service Bulletin	GROUP Engine Mechanical	NUMBER 21-EM-001H
	DATE JANUARY 2021	MODEL(S) Elantra (MD / UD), Elantra GT (GD), Elantra Coupe (JK)
SUBJECT: NU ENGINE CYLINDER BLOCK INSPECTION & REPLACEMENT		

Description: This bulletin describes the procedure to inspect an engine exhibiting noise between the cylinder block and piston due to possible scuffing on one or more cylinder walls. Follow the procedure outlined in this bulletin to inspect and replace the short engine assembly if scuffing is observed.

Applicable Vehicles: Certain 2011-2016MY Elantra (MD) vehicles with 1.8L engine
 Certain 2011-2016MY Elantra (UD) vehicles with 1.8L engine
 Certain 2013MY Elantra GT (GD) vehicles with 1.8L engine
 Certain 2013MY Elantra Coupe (JK) vehicles with 1.8L engine

Parts Information:

Part Name	Part Number	Figure	Remarks
ENGINE ASSY – SHORT (NU ENGINE)	Refer to Applicable Parts Catalog		NOTE: Correct part number must be applied (use VIN filter for catalog search) to maintain proper compatibility for fit and function.
COVER ASSY - TIMING CHAIN & OIL PUMP			
GASKET KIT-ENGINE OVERHAUL			
BOLT-CYLINDER HEAD	22320-2E000 22321-2E000		(QTY 6) 22320-2E000 (QTY 4) 22321-2E000

NOTES:

- Consult the Hyundai Warranty Policy & Procedures to determine New or Reman engine usage.
- As shown below, use P/N search filter by VIN function in the applicable parts catalog.
 (Parts Catalog display screen may vary depending on the system and services used.)

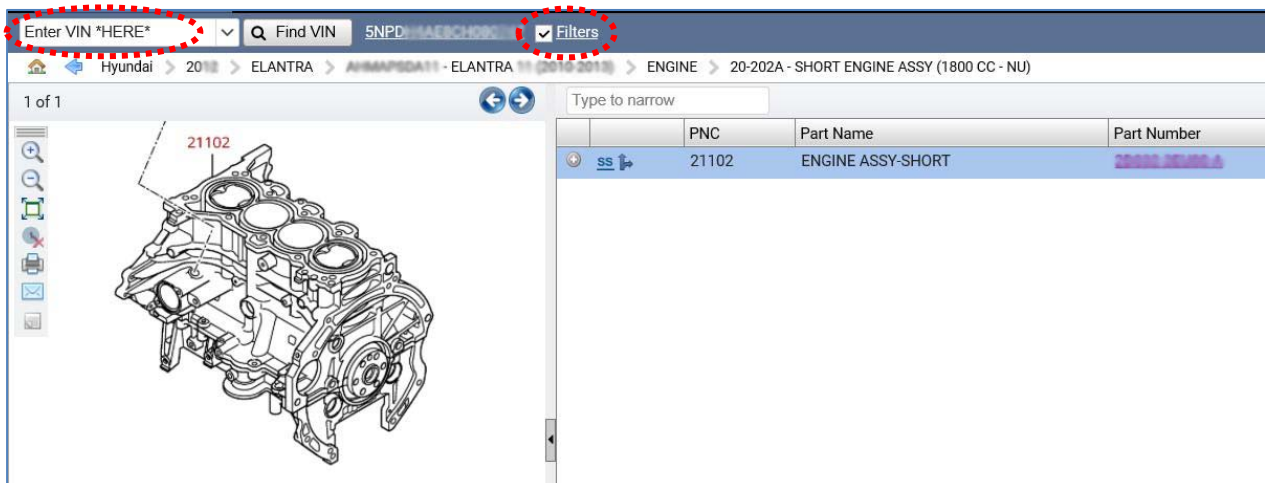

Circulate To: General Manager, Service Manager, Parts Manager, Warranty Manager, Service Advisors, Technicians, Body Shop Manager, Fleet Repair

SUBJECT: NU ENGINE CYLINDER BLOCK INSPECTION & REPLACEMENT

SST Information:

Description	Part Number	Figure	Remarks
Digital Inspection Borescope / Camera	Commercially Available Equivalent		Purchase borescope tool from commercial retailers or suppliers.

NOTE: A commercially available inspection borescope with an output to a digital display screen is required. It must provide clear resolution to inspect cylinder wall surfaces using a 90 degree camera probe adapter.

Warranty Information:

Model	Op. Code	Operation	Transmission Type	Op. Time	ENGINE Replacement Part	Causal Part	Nature Code	Causal Code
Elantra (MD), Elantra (UD), Elantra GT (GD), Elantra Coupe (JK)	10D009R0	Cylinder Block Inspection Only	Both	0.5 M/H	N/A	22135-2E000	Q52	ZZ5
MD/UD/GD/JK	10D009R1	Cylinder Block Inspection and Short-Engine Replacement	Manual	9.6 M/H	37YM2-2EW00	37YM2-2EW00		
MD/UD/GD/JK	10D009R2	Cylinder Block Inspection and Short-Engine Replacement	Automatic	9.8 M/H	37YM2-2EW00	37YM2-2EW00		
MD/UD/GD/JK	10D009R3	Cylinder Block Inspection and Short-Engine Replacement	Manual	9.6 M/H	37YM2-2EW00HRM	37YM2-2EW00HRM		
MD/UD/GD/JK	10D009R4	Cylinder Block Inspection and Short-Engine Replacement	Automatic	9.8 M/H	37YM2-2EW00HRM	37YM2-2EW00HRM		
MD/GD/JK	10D009R5	Cylinder Block Inspection and Short-Engine Replacement	Manual	9.6 M/H	45YM2-2EW00	45YM2-2EW00		
MD/GD/JK	10D009R6	Cylinder Block Inspection and Short-Engine Replacement	Automatic	9.8 M/H	45YM2-2EW00	45YM2-2EW00		
MD/GD/JK	10D009R7	Cylinder Block Inspection and Short-Engine Replacement	Manual	9.6 M/H	45YM2-2EW00HRM	45YM2-2EW00HRM		
MD/GD/JK	10D009R8	Cylinder Block Inspection and Short-Engine Replacement	Automatic	9.8 M/H	45YM2-2EW00HRM	45YM2-2EW00HRM		
MD/UD/JK	10D009R9	Cylinder Block Inspection and Short-Engine Replacement	Manual	9.6 M/H	38YM2-2EW00	38YM2-2EW00		
MD/UD/JK	10D009RA	Cylinder Block Inspection and Short-Engine Replacement	Automatic	9.8 M/H	38YM2-2EW00	38YM2-2EW00		

SUBJECT: NU ENGINE CYLINDER BLOCK INSPECTION & REPLACEMENT

Model	Op. Code	Operation	Transmission Type	Op. Time	ENGINE Replacement Part	Causal Part	Nature Code	Causal Code
MD/UD/JK	10D009RB	Cylinder Block Inspection and Short-Engine Replacement	Manual	9.6 M/H	38YM2-2EW00HRM	38YM2-2EW00HRM	Q52	ZZ5
MD/UD/JK	10D009RC	Cylinder Block Inspection and Short-Engine Replacement	Automatic	9.8 M/H	38YM2-2EW00HRM	38YM2-2EW00HRM		
MD/UD/GD/JK	10D009RD	Cylinder Block Inspection and Short-Engine Replacement	Manual	9.6 M/H	33ZN2-2EX00	33ZN2-2EX00		
MD/UD/GD/JK	10D009RE	Cylinder Block Inspection and Short-Engine Replacement	Automatic	9.8 M/H	33ZN2-2EX00	33ZN2-2EX00		
MD/UD/JK	10D009RF	Cylinder Block Inspection and Short-Engine Replacement	Manual	9.6 M/H	70YM1-2EW00	70YM1-2EW00		
MD/UD/JK	10D009RG	Cylinder Block Inspection and Short-Engine Replacement	Automatic	9.8 M/H	70YM1-2EW00	70YM1-2EW00		

NOTE 1: Submit Claim on Campaign Claim Entry Screen

NOTE 2: Submit **campaign labor operation based on Engine replacement part used.**

NOTE 3: PA approval **required** for Op codes with **Engine replacement.**

NOTE 4: Labor for timing chain & oil pump cover assembly, gasket kit, and cylinder bolt is included in campaign labor op time.

NOTE 5: For parts above (timing chain & oil pump cover assembly, gasket kit, and cylinder bolt) and any other parts in need of replacement or if **additional labor** is required while performing this repair, follow the process below.

- Submit one compiled separate claim using the same Repair Order number AND
- Submit with **21102NTT** using the engine Causal Part number associated with the Engine replacement Op Code used AND
- Ensure part replacement and punch times are accurate and that they match the labor performed along with the service manager's signature approving the TT time.
 - For TT time best practices, refer to Hyundaidealer.com > Service Tab > Documents Library > Warranty > ATT-NTT Documentation and Claim Submission Guide
- **If the part replacement does not require additional labor**, follow the above steps and use the system minimum of 0.1 labor time with a quantity of 1.

NOTE 6: Warranty Policy Applies

Service Procedure Flowchart:

All STUI Pictures require the VIN clearly visible in the photo. Use copy of RO or last 6-digits of VIN on paper.

All STUI Videos require starting at the VIN at the windshield or doorjamb (held there for 2-3 seconds), then move and hold the tablet 1-2 ft. near the engine block while recording the noise.

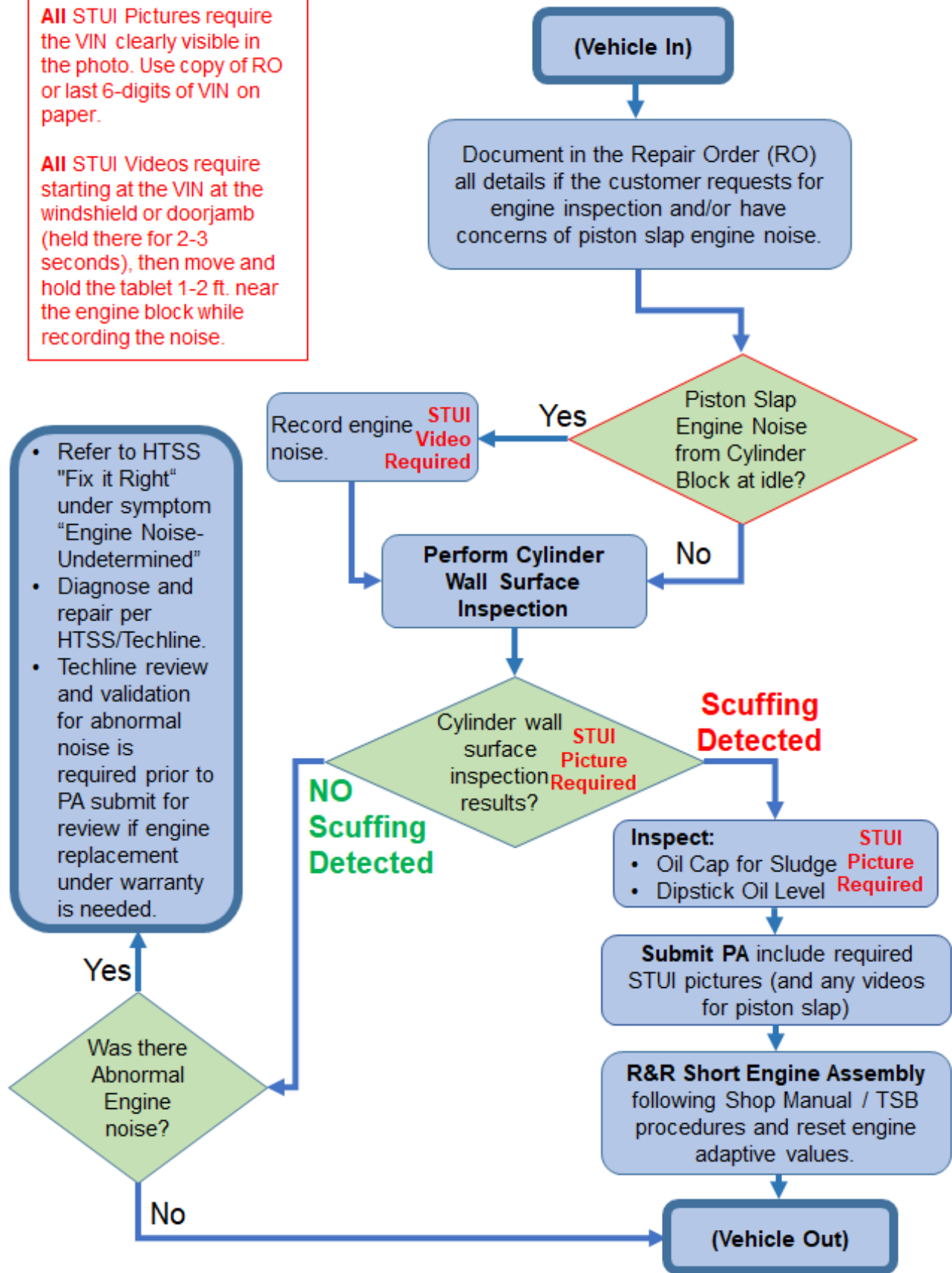

Service Procedure:

A. Cylinder Wall Surface Inspection

1. Verify the engine is off.

Remove the engine cover (A).

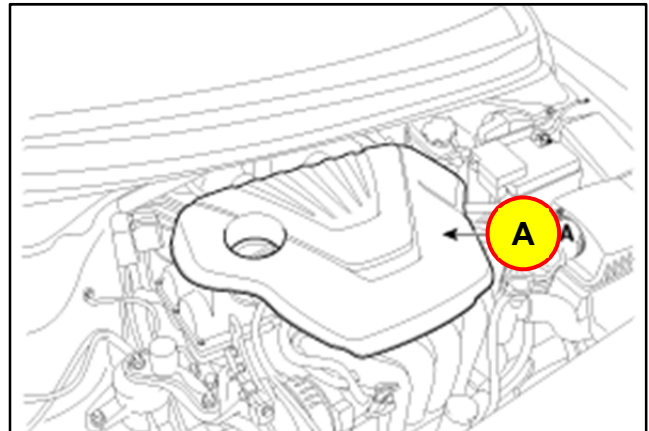

2. Disconnect the coil connectors, and remove the spark plugs (B).

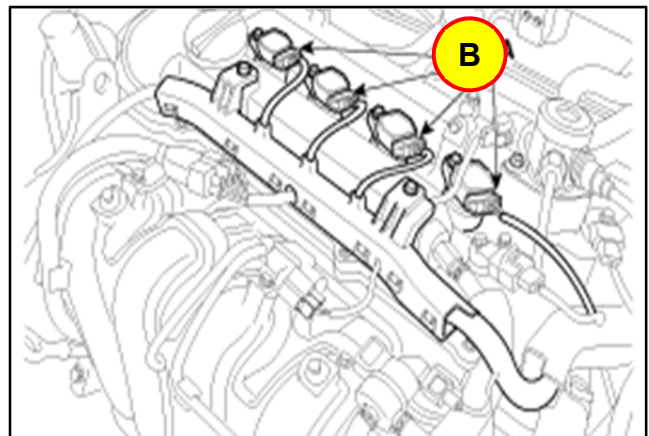

3. **NOTE:** In this step, a borescope camera will be inserted through the spark plug holes (C) to inspect the cylinder walls for scuffing.
 - a) Rotate the engine to Cylinder #1 TDC (Top Dead Center).
 - b) Inspect cylinders #2 and #3.
 - c) Remove the borescope camera from the spark plug hole (to prevent crush damage to the probe tip when rotating the engine).
 - d) Rotate the engine 180 degrees for Cylinder #1 BTDC (Bottom Top Dead Center).
 - e) Inspect cylinders #1 and #4.

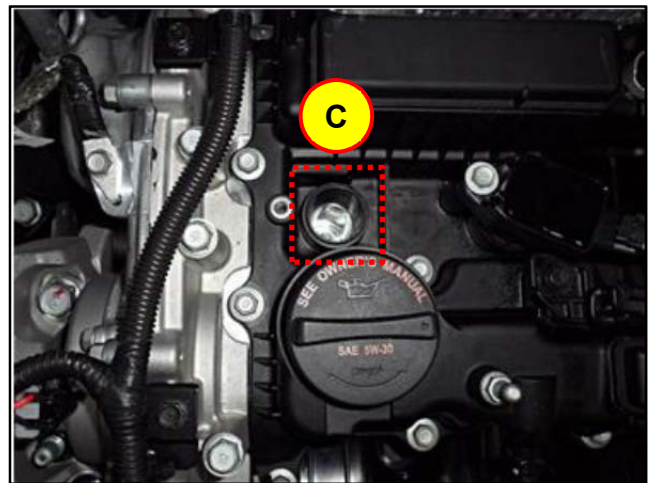

4. Inspect the cylinder walls for signs of vertical scuffing pattern (refer to the reference pictures as shown on the right for scuffing examples).

➤ **If no scuffing is found**, then inspection is complete. Reinstall all parts in reverse order of removal.

➤ **If scuffing is identified**, use STUI to take a picture of the borescope display of each identified cylinder wall surface if scuffing is found.

Once completed, upload the images using the STUI Camera "Select a picture in Gallery" function.

- ❖ In addition, the following 2 items must be included for PA approval process.
 - a) Picture of the oil cap underside
 - b) Picture of oil level on dipstick

(All STUI pictures require the VIN clearly visible in the photo. Use copy of RO or last 6-digits of VIN on paper.)

Submit PA with STUI pictures to replace the short engine assembly.

NOTE: Some borescope units may display the vertical scuffing differently (not up/down). Be sure to position the borescope display accordingly to show the vertical scuffing correctly per below for the STUI pictures.

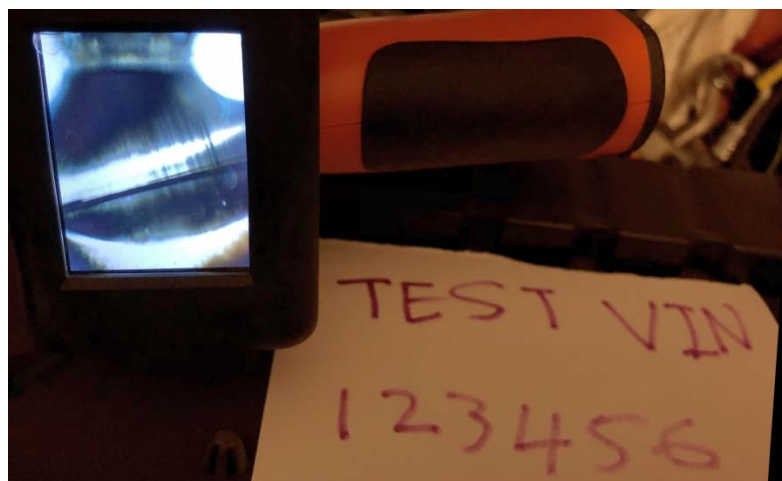
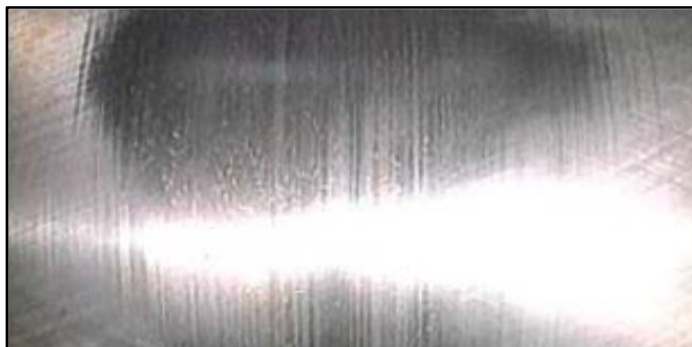

B. Short Engine Assembly Replacement

1. Replace the Short Engine Assembly.

NOTE: In addition, replace the Timing Chain & Oil Pump Cover Assembly.

- Refer to the parts catalog for the applicable part numbers.
- Refer to the shop manual for the engine replacement procedure.

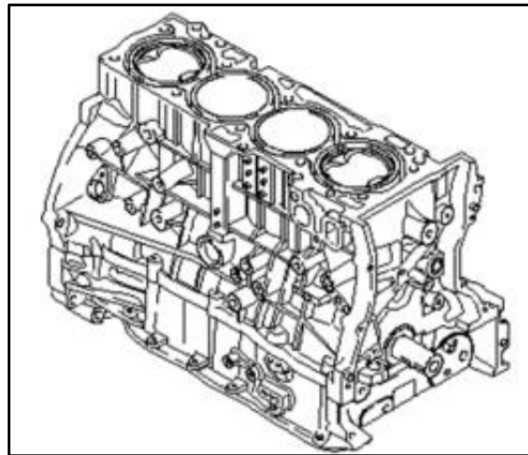

NOTICE

Refer to the following TSB's:

- **14-EM-004 "ENGINE TIMING CHAIN AND GEAR PARTS INFORMATION"** to confirm parts compatibility.
- **10-EM-003 "ENGINE OIL PUMP REPLACEMENT GUIDELINES DURING ENGINE REPLACEMENT"** to replace the timing chain & oil pump cover assembly due to piston/cylinder wall scuffing.
- **17-EM-001 "INTAKE AND EXHAUST SYSTEM INSPECTION AND REPLACEMENT GUIDELINES DURING ENGINE REPLACEMENT"** to inspect and clean the related engine components prior to reinstallation.

- Reuse the spark plugs (replace under customer pay if replacement service interval is due).
2. Reinstall all parts in reverse order of removal.
 3. The service procedure is complete.