



GROUP
ENG

MODEL
2021MY
Sorento (MQ4 HEV)

NUMBER
225

DATE
January 2021

TECHNICAL SERVICE BULLETIN

SUBJECT: **SERVICE ACTION: CENTER AND REAR MUFFLER
INSPECTION AND REPAIR (SA461)**

This bulletin provides the procedure to inspect the center muffler on some 2021MY Sorento (MQ4a HEV) vehicles equipped with 1.6L T-GDI engine, produced from September 02, 2020 through December 30, 2020, which may exhibit a poor engine start up due to freezing of condensation in the muffler(s) after parking the vehicle for an extended period of time in cold/freezing temperature. The issue does not affect drivability once the vehicle is started. Follow the procedure outlined in this bulletin to inspect the center muffler and drill a 3/16" hole on both the center and rear mufflers to improve condensation drainage. Before conducting the procedure, verify that the vehicle is included in the list of affected VINs.

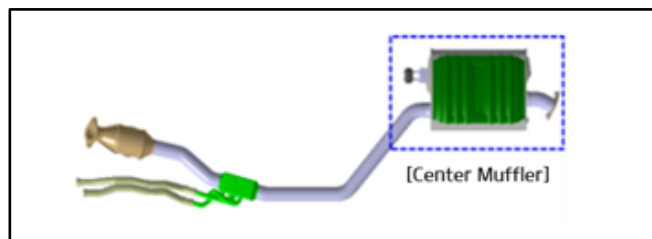

* NOTICE

A Service Action is a repair program without customer notification that is performed during the warranty period. Any dealer requesting to perform this repair outside the warranty period will require DPSM approval.

Repair status for a VIN is provided on WebDCS (Service → Warranty Coverage → Warranty Coverage Inquiry → Campaign Information). Not completed Recall / Service Action reports are available on WebDCS (Consumer Affairs → Not Completed Recall → Recall VIN → Select Report), which includes a list of affected vehicles.

This issue number is SA461.

Printed TSB copy is for reference only; information may be updated at any time.
Always refer to KGIS for the latest information.

Circulate To: General Manager Service Manager Parts Manager
 Service Advisors Technicians Body Shop Manager Fleet Repair

Inspection Procedure:

1. Inspect the center muffler for the following conditions:
 1. Deformation due to clog or physical deformation due to ice expansion.
 2. Leakage from corrosion/perforation damage from the welded area(s).

If conditions 1 or 2 apply, replace the center muffler assembly under normal warranty and perform the 'Repair Procedure' outlined below after replacement.

If conditions 1 or 2 **do not** apply, follow the '**Repair Procedure**' outlined below.

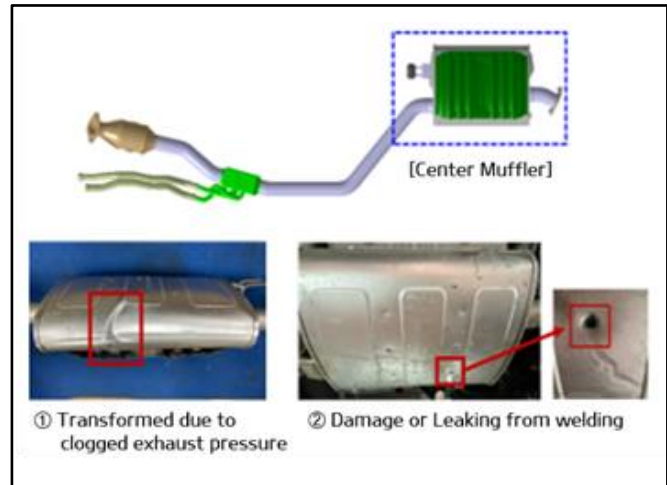
**Repair Procedure:**

1. On the front of the center muffler (inlet side, IN), measure from the edge of the muffler retaining bracket 26mm to the right and draw a line. Then measure 15mm from the bottom of the muffler and mark the spot to be drilled.
2. Using a power hand drill and 3/16" drill bit, drill a hole in the marked spot in the front of the center muffler as shown.

Proceed to step 3 to drill the rear muffler.

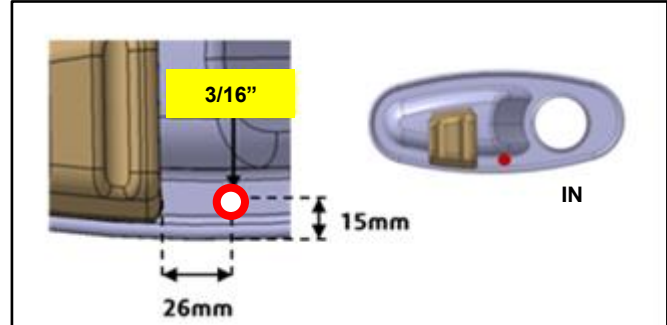

SUBJECT:

SERVICE ACTION: CENTER AND REAR MUFFLER
INSPECTION AND REPAIR (SA461)

3. On the front of the rear muffler (inlet side, IN), measure from the bottom right corner/edge of the muffler retaining bracket, 33mm to the right and draw a line. Then measure down from bottom corner/edge of the muffler retaining bracket 33mm and mark the spot to be drilled.

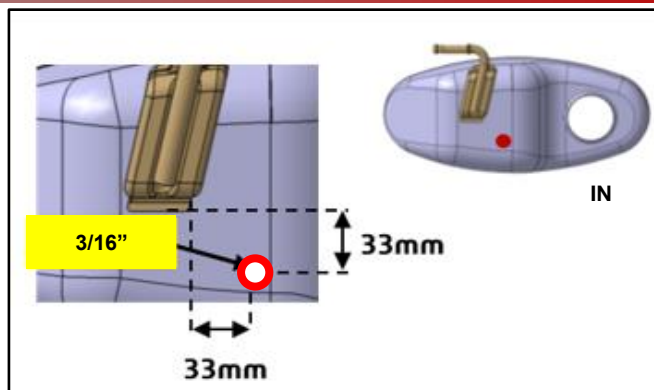

4. Using a power hand drill and 3/16" drill bit, drill a hole in the marked spot in the front of the rear muffler as shown.



5. This service action is now complete.



SUBJECT:

SERVICE ACTION: CENTER AND REAR MUFFLER INSPECTION AND REPAIR (SA461)

AFFECTED VEHICLE RANGE:

Model	Production Date Range
Sorento (MQ4 HEV)	September 02, 2020 to December 30, 2020

REQUIRED TOOL:

Tool Name	Figure	Remark
Power Drill		Depending on the length of drill being used, you may consider using SST KQ557 B2400QK tool kit using the angle drill
3/16" (3mm) Drill Bit		

WARRANTY INFORMATION:

N Code: N99 C Code: C99

Claim Type	Causal P/N	Qty.	Repair Description	Labor Op Code	Op Time	Replacement P/N	Qty.
V	28600 P4660	0	(SA461) Center & Rear Muffler Inspection and Repair	210001R0	0.3 M/H	N/A	0

*** NOTICE**

VIN inquiry data for this repair is provided for tracking purposes only. Kia retailers should reference SA461 when accessing the WebDCS system.