

January 18, 2021

Version 1

Blower Motor Is Noisy, Runs Slowly, or Intermittently Stops Working

AFFECTED VEHICLES

Year	Model	Trim Level	VIN Range
2015-20	Fit	ALL	ALL

SYMPTOM

The blower motor makes excessive noise, runs slowly, or intermittently stops working.

CORRECTIVE ACTION

Inspect the dust and pollen filter and, if needed, replace it with a new activated charcoal filter. Then, replace the blower motor.

PARTS INFORMATION

Part Name	Part Number	Quantity
Blower Motor	79310-T5R-A01	1
Filter Element (Activated Charcoal Filter)	80291-T5A-J01	1

TOOL INFORMATION

Tool Name	Tool Number	Quantity
Drop Down Glove Box Cover	VSB02C000051	1

WARRANTY CLAIM INFORMATION

The normal warranty applies.

Operation Number	Description	Flat Rate Time	Defect Code	Symptom Code	Template ID	Failed Part Number
612120	Inspect the filter (no replacement needed). Replace the blower motor.	0.3 hr	03214	03217	A21005A	79310-T5R-A01
612120	Replace the filter and blower motor.	0.3 hr	03214	03217	A21005B	79310-T5R-A01

Skill Level: Repair Technician

CUSTOMER INFORMATION: The information in this bulletin is intended for use only by skilled technicians who have the proper tools, equipment, and training to correctly and safely maintain your vehicle. These procedures should not be attempted by "do-it-yourselfers," and you should not assume this bulletin applies to your vehicle, or that your vehicle has the condition described. To determine whether this information applies, contact an authorized Honda automobile dealer.

INSPECTION

1. Turn the ignition to OFF.
2. Open the glove box. Use the Drop Down Glove Box Cover (T/N VSB02C000051) to keep items in the glovebox secure and organized.



3. Drop the glove box down to access the area behind the dashboard.

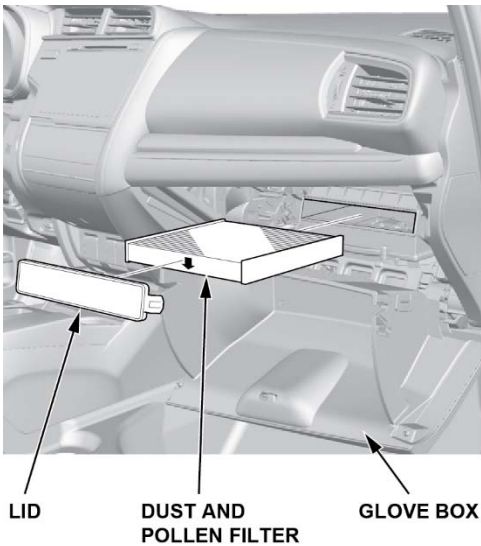

4. Remove the lid, then remove the dust and pollen filter.

OLD DUST AND POLLEN FILTER



NEW ACTIVATED CHARCOAL FILTER



- If the filter is not an activated charcoal filter, replace it with an activated charcoal filter. Then, go to REPAIR PROCEDURE.
- If the filter is an activated charcoal filter, do not replace it. Reinstall it and go to REPAIR PROCEDURE.

REPAIR PROCEDURE

1. Remove the passenger's dashboard undercover.

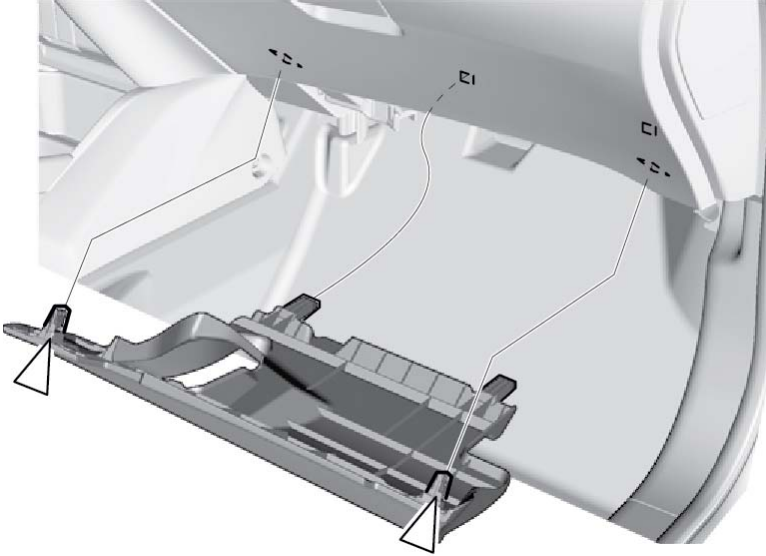

2. Disconnect the blower motor connector.

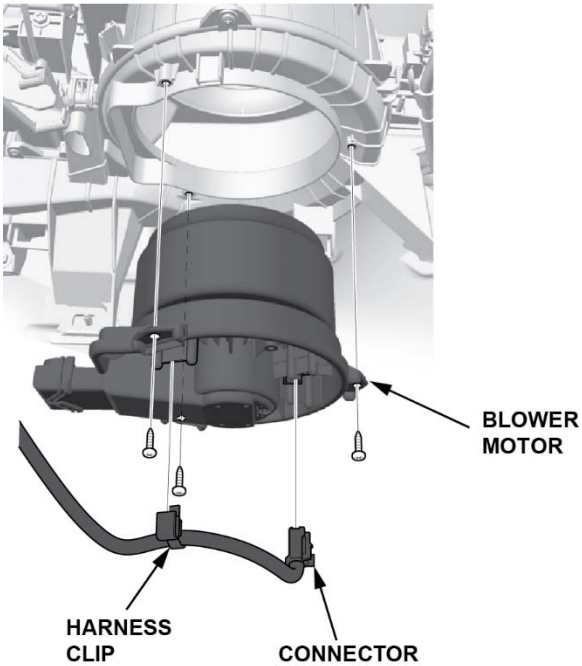

3. Remove the harness clip.
4. Remove the three screws and the blower motor.
5. Install the new blower motor with the three screws.
6. Install all other parts in the reverse order of removal.
7. Check the operation of the blower motor, and make sure there is no air leakage.

END