

01/15/2021
CAL FTL 88-001

Subject: Freightliner M2 Forward-Frame Extension Hood Mount Bracket Gusset Installation

Models Affected: Specific M2 vehicles manufactured between December 1, 2016 and January 1, 2021 equipped with an eight inch forward-frame extension

Our records indicate that you are the owner of certain vehicles, and therefore DTNA has decided to share the following documentation with you.

Please see the attached communication in this email. We hope you find this information helpful.

01/15/2021
CAL FTL 88-001

Work Instructions

Subject: Freightliner M2 Forward-Frame Extension Hood Mount Bracket Gusset Installation

Models Affected: Specific M2 vehicles manufactured between December 1, 2016 and January 1, 2021 equipped with an eight inch forward-frame extension

Parts

Parts Required		
Item Description	Part Number	Quantity
Left-hand gusset	15-30784-000	1
Right-hand gusset	15-30784-001	1

Table 1, Parts Required

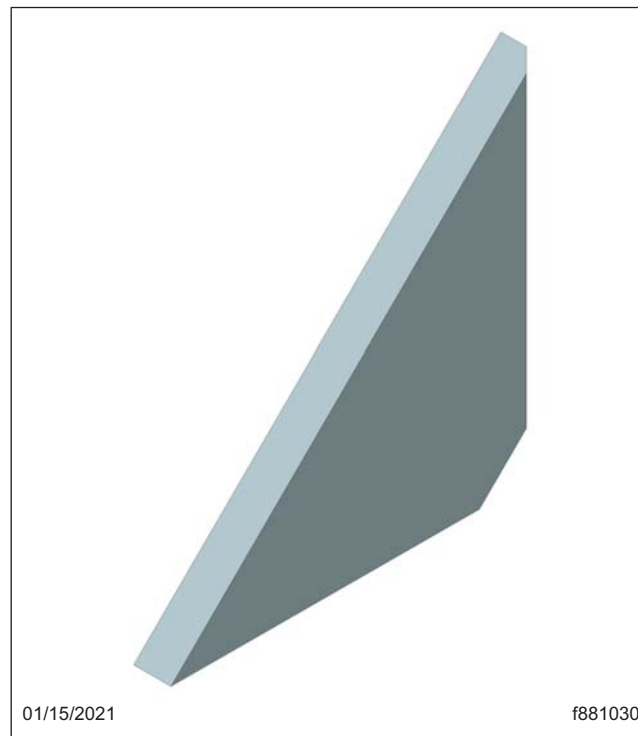

Fig. 1, Hood Mount Bracket Gusset, LH shown (RH opposite)

Work Instructions

1. Park the vehicle on a level surface, shut down the engine, and set the parking brake. Check the tires.
2. Raise the hood and rotate it to the fully raised rest position.

01/15/2021
CAL FTL 88-001

3. Locate the hood support brackets at the left-hand and right-hand forward frame extension fabrications. See [Fig. 2](#). The area where the gussets will be installed is directly below the lower-hood strut mounting points. Both a right-hand and left-hand gusset need to be installed to complete the repair.

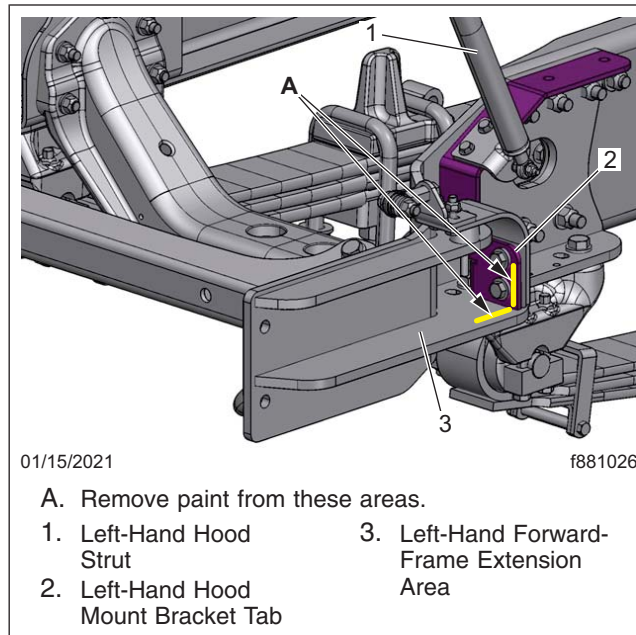

Fig. 2, Hood Support Bracket and Paint Removal Location

4. To give increased access to the gusset weld areas, remove the hood mounting bracket and fasteners. For instructions, see the *Business Class M2 Workshop Manual* section 88.00.
5. Gently grind or sand away the topcoat paint on the vertical surface of the left-hand mounting tab at the edge and on the left-hand horizontal surface of the frame at the edge until bare metal is visible. See [Fig. 2](#). This is in preparation for welding the gusset into position.
6. Clean the bare metal areas with solvent and allow to dry thoroughly.
7. Cover the neighboring components with a weld blanket or other appropriate heat shield material to protect them from weld sparks.
8. Position the bracket gusset between the vertical mounting tab and the horizontal frame extension area. See [Fig. 3](#).

01/15/2021
CAL FTL 88-001

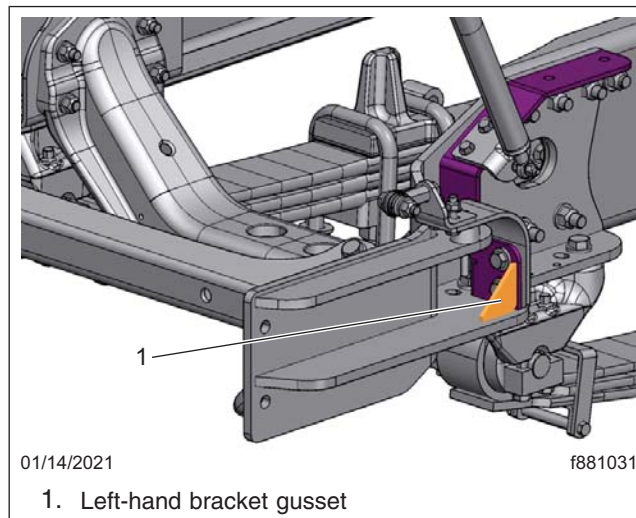

Fig. 3, Left-Hand Bracket Gusset in Place

9. Apply welds at the vertical and horizontal edges of the gusset.
10. Allow the work area to cool and then apply primer/rust inhibitor and topcoat paint to the welded areas.
11. If removed, install the hood mounting bracket and fasteners.
12. Repeat steps 4 through 11 to install the right-hand bracket gusset.