



STAR ONLINE PUBLICATION

Case Number: S2008000160

Release Date: 10/21/2020

Symptom/Vehicle Issue: No Start, DTC U0426-31 Minikrypt Error, Key Stuck

Customer Complaint/ Technician Observation: Vehicle does not start at times. Key may get stuck in ignition.

NOTE: If shifter has been in park for *more than 30 seconds* and key *has not* been turned to OFF, the key might be jammed/trapped after switching to off. This behavior is by design “NO ISSUE”. Perform a key-on/key-off cycle to smoothly release the Key.

Technician observed, DTC U0426-31 Minikrypt Error active in BCM. This can be due to the PCM not powering down when the ignition key is turned off as expected. Ignition key status voltage must match the key position voltages for proper operations of the PCM, BCM and Shifter.

After market equipment has been found to contribute to ignition circuit voltage discrepancies. At the ignition switch verify the proper voltages match each ignition switch position **START** F26 circuit, **RUN START** F22 circuit, and **RUN** F30, F722 circuit. See circuit diagrams, Fig 1, 2, 3.

This document does not authorize warranty repairs. This communication documents a record of past experiences. STAR Online does not provide any conclusions about what is wrong with the vehicle. Rather, it captures all previous cases known that appear to be similar or related to the vehicle symptom / condition. You are the expert, and you are responsible for deciding on the appropriate course of action.

Contact STAR Center, or your Technical Assistance Center Via TechCONNECT or eCONTACT ticket if no solution is found

STAR ONLINE PUBLICATION

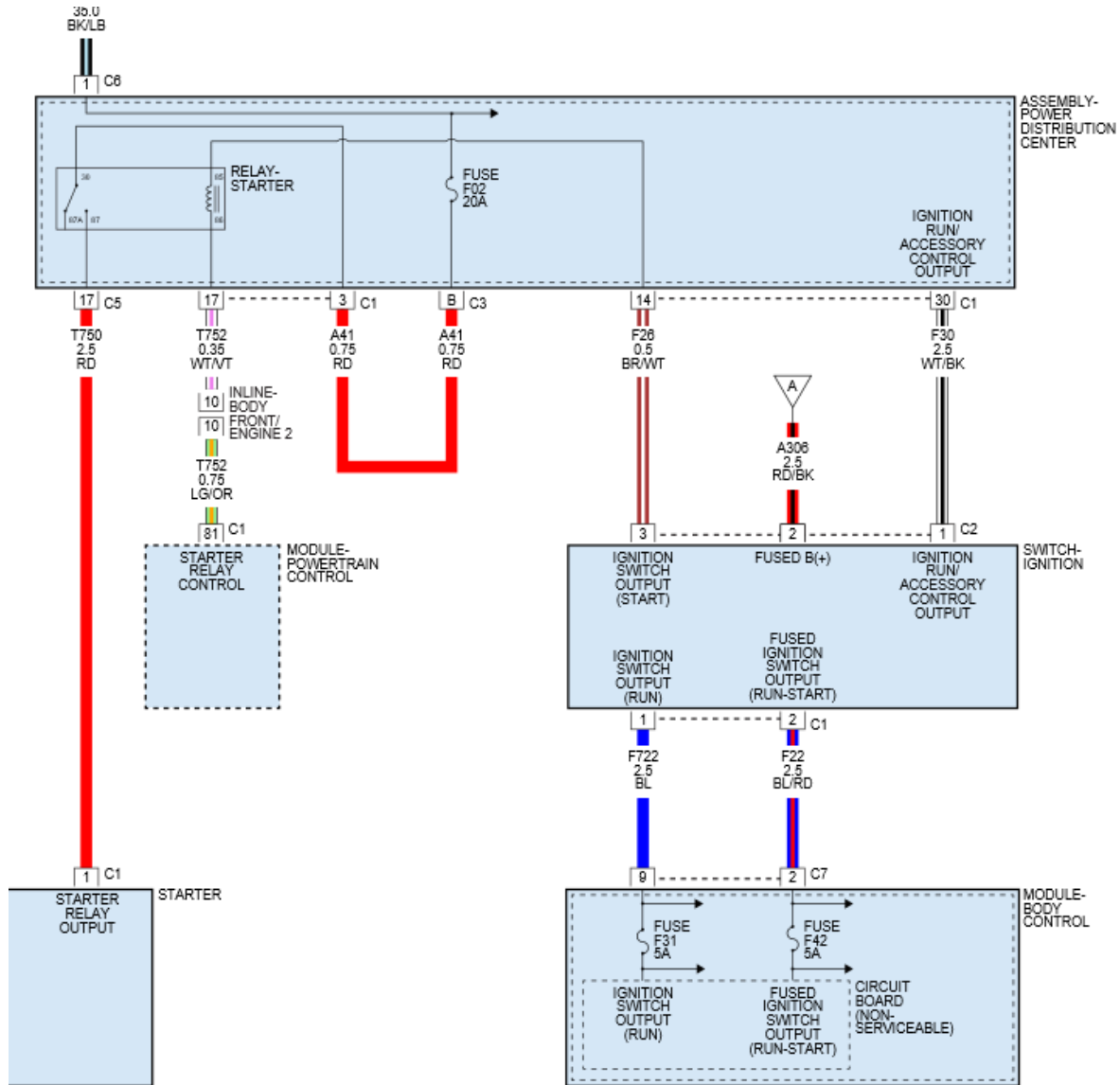

Fig 1

This document does not authorize warranty repairs. This communication documents a record of past experiences. STAR Online does not provide any conclusions about what is wrong with the vehicle. Rather, it captures all previous cases known that appear to be similar or related to the vehicle symptom / condition. You are the expert, and you are responsible for deciding on the appropriate course of action.

Contact STAR Center, or your Technical Assistance Center Via TechCONNECT or eCONTACT ticket if no solution is found

STAR ONLINE PUBLICATION

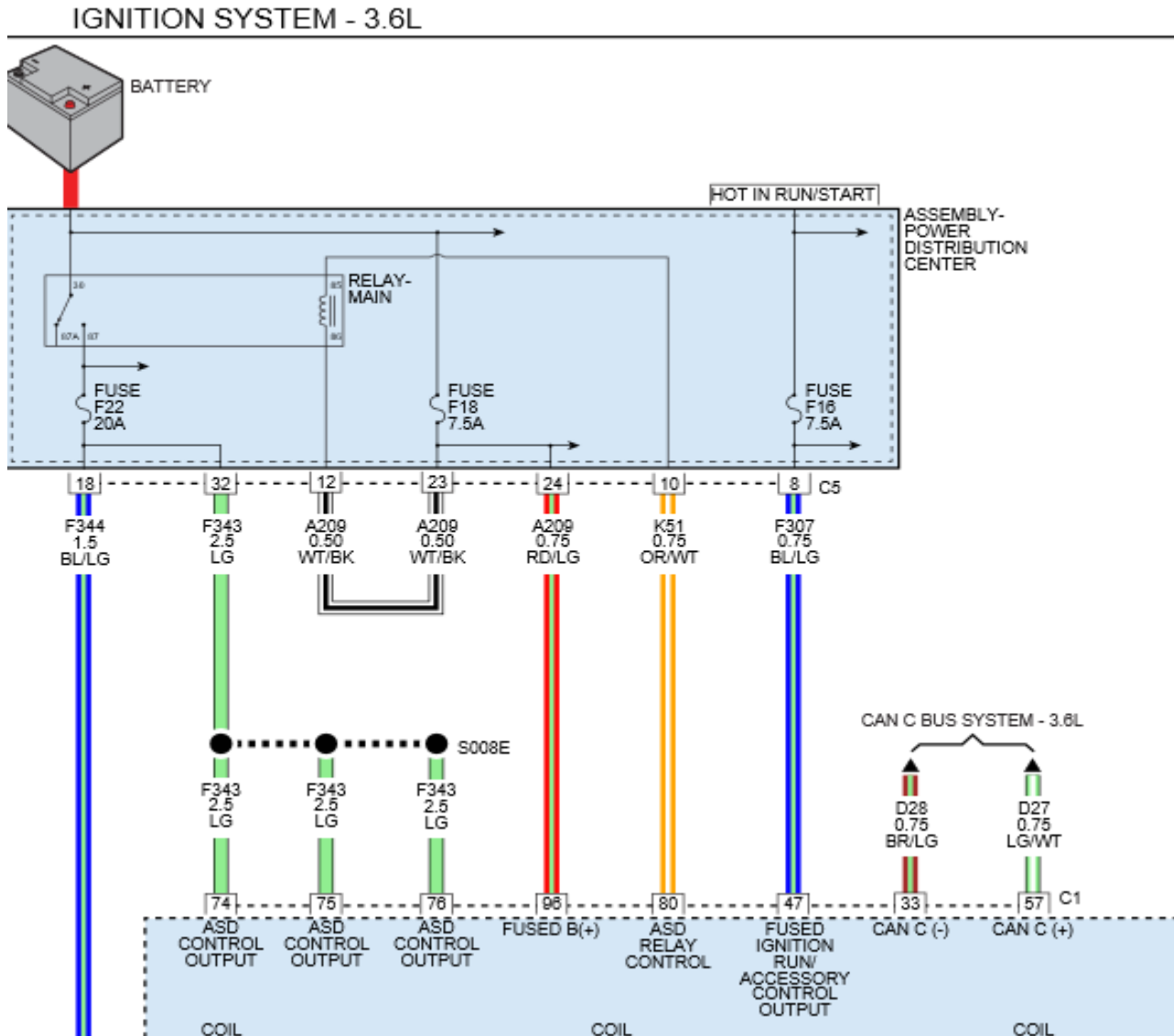

Fig 2

This document does not authorize warranty repairs. This communication documents a record of past experiences. STAR Online does not provide any conclusions about what is wrong with the vehicle. Rather, it captures all previous cases known that appear to be similar or related to the vehicle symptom / condition. You are the expert, and you are responsible for deciding on the appropriate course of action.

Contact STAR Center, or your Technical Assistance Center Via TechCONNECT or eCONTACT ticket if no solution is found

STAR ONLINE PUBLICATION

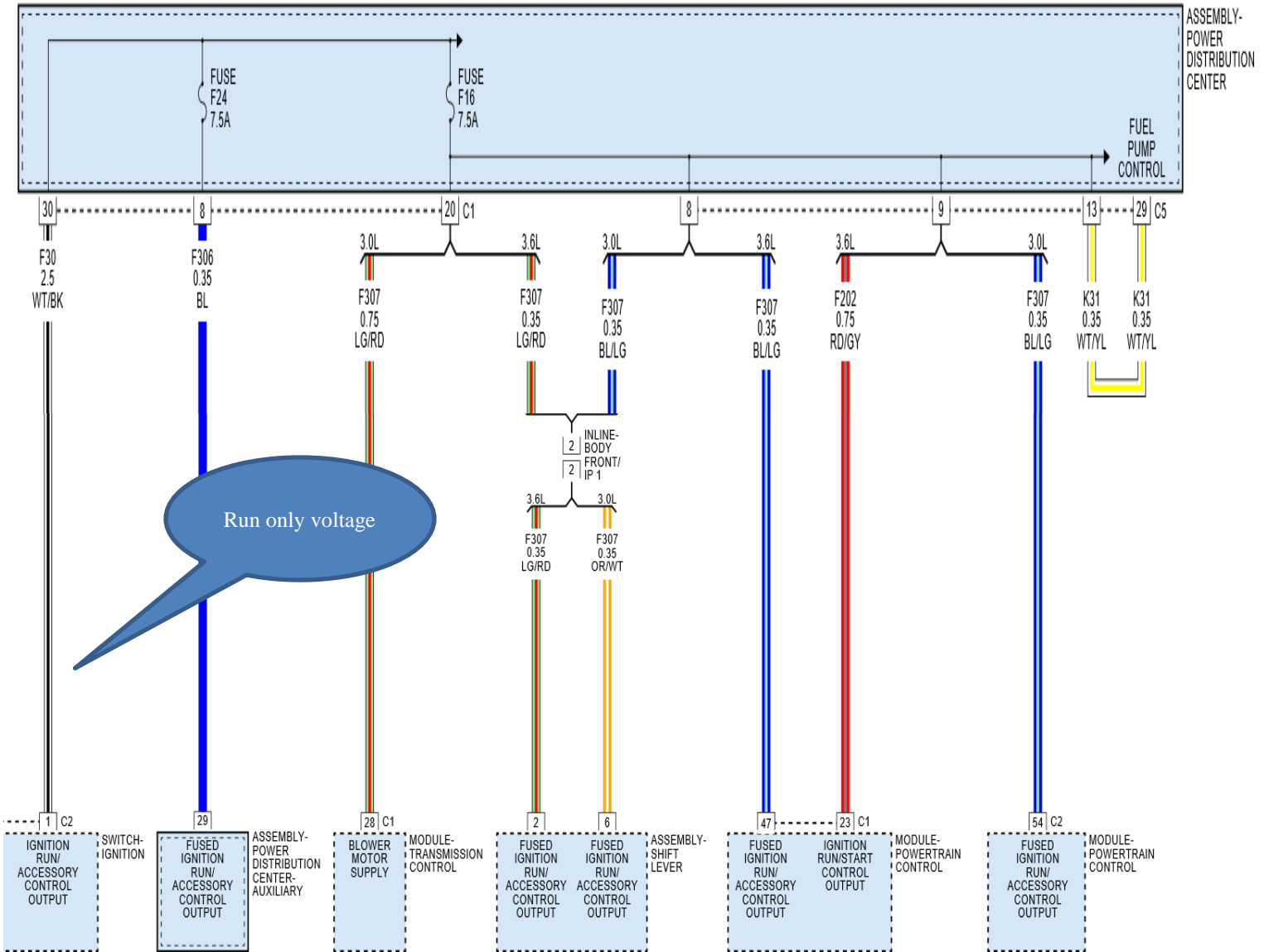

Fig 3

This document does not authorize warranty repairs. This communication documents a record of past experiences. STAR Online does not provide any conclusions about what is wrong with the vehicle. Rather, it captures all previous cases known that appear to be similar or related to the vehicle symptom / condition. You are the expert, and you are responsible for deciding on the appropriate course of action.

Contact STAR Center, or your Technical Assistance Center Via TechCONNECT or eCONTACT ticket if no solution is found