

HUSQVARNA TECHNICAL BULLETIN HTB2012

JULY 2, 2020

RECALL - REMEDY NOTICE

RESUME VEHICLE SALES AFTER THE REMEDY REPAIR HAS BEEN PERFORMED

FUEL TANK REPLACEMENT - REMEDY REPAIR FOR FUEL SEEPAGE AT THE FUEL LEVEL SENSOR MOUNTING AREA AND FUEL PUMP MOUNTING AREA

AFFECTED MODELS:

2018, 2019, 2020 – VITPILEN 701

2019, 2020 – SVARTPILEN 701

RESTRICTIONS: AFFECTED MODELS ARE LINKED BY VIN IN HUSQVARNA DEALER.NET

THIS MODIFICATION HAS TOP PRIORITY AND MUST BE PERFORMED IMMEDIATELY TO ENSURE CUSTOMER SAFETY

INITIAL INFORMATION:

Husqvarna Motorcycles North America, Inc. had published a prior Technical Bulletin (HTB2011) that informed you to stop the sale of the SVARTPILEN 701 and VITPILEN 701 motorcycles listed above due to the possibility of fuel seepage or leakage from the fuel level sensor mounting area and the fuel pump mounting area. HTB2011 informed you that the fuel leak occurrence was being investigated and that a remedy was in the process of being determined.

The remedy for this recall is now available and following are the details on how it must be performed.

Husqvarna Motorcycles North America, Inc. has decided that a defect which relates to motor vehicle safety exists with the motorcycle models and years listed above in which the fuel may seep or leak from the fuel level sensor mounting area and fuel pump mounting area. To ensure the highest level of safety, performance, reliability and customer satisfaction, it is necessary to install a newly developed fuel tank that has an increased wall thickness along with new gaskets for the fuel level sensor, fuel pump, and fuel tank insert on all affected models. The new fuel tank with thicker walls has an improved sealing behavior.

The stop sale has been lifted and affected SVARTPILEN 701 and VITPILEN 701 motorcycles can be sold to retail customers again only after the remedy repair has been performed.

COPYRIGHT NOTICE

The user acknowledges that all components of this technical information are Husqvarna's and/or third parties' copyright protected property. Alteration, assignment, distribution and reproduction are forbidden.

LIMITATION OF LIABILITY

The information included in or available through this technical information may include inaccuracies or errors. In no event shall Husqvarna and/or its suppliers be liable for any damages whatsoever, arising out of or in connection with the use of this technical information. Please always refer to the Husqvarna owners and repair manuals for proper instructions or contact the Husqvarna Dealer Services Department. ©2020 Husqvarna Motorcycles North America, Inc. – All rights reserved

HUSQVARNA TECHNICAL BULLETIN HTB2012

JULY 2, 2020

It has been determined that on affected units during operation there is a possibility of the fuel tank leaking from the fuel level sensor mounting area and the fuel pump mounting area.

In extreme cases this could result in the possibility of a fuel leak which may result in damage or possible fire, which could cause injury or death to the rider or others. The cause of the defect is due to the unevenness that may occur on the sealing surfaces in the area of the fuel pump and fuel level sensor during the vehicles life cycle. If unevenness occurs it does not allow for proper sealing between the fuel level sensor mounting area and fuel pump mounting area. To remedy this defect, a new fuel tank has been developed to install on the motorcycle to prevent fuel leakage. The new fuel tank has an increased wall thickness to prevent unevenness and improve sealing behavior. The increased wall thickness reduces the tank volume by approximately 0.8 liters. The total fuel tank capacity of the new fuel tank is approximately 11.2 liters.

Husqvarna Motorcycles is notifying all registered owners of affected SVARTPILEN 701 and VITPILEN 701 motorcycles by mail. A copy of the customer letter is included in this bulletin. The customer should take the letter along with the affected motorcycle to an authorized Husqvarna Motorcycles Dealer to have the new fuel tank installed along with new gaskets for the fuel level sensor, fuel pump, and fuel tank insert. After the fuel tank is replaced a new flash file must also be flashed into the dashboard for proper fuel level calibration.

This recall must only be performed by trained technicians with proper equipment. Dealers are not to send out parts to customers and should take every reasonable action to make sure the customer does not try to repair or perform the recall on their vehicle. Doing so is a violation of Federal law. Dealers are to properly record the repair of the recall, report and return only the requested parts per this recall to Husqvarna Motorcycles North America, Inc.

Dealers must perform the installation of the new fuel tank along with the new gasket for the fuel level sensor, fuel pump, and fuel tank insert on all affected motorcycles in their inventory prior to any customer delivery. It is also necessary to reflash the dashboard for proper fuel level calibration. Any affected SVARTPILEN 701 and VITPILEN 701 motorcycles received directly from Husqvarna Motorcycles North America, Inc. requires the installation of the new fuel tank, fuel level sensor gasket, fuel pump gasket, and fuel tank insert gasket prior to customer delivery. Affected units acquired through dealer transfers or trades must be checked and remedied in Husqvarna Dealer.net to ensure and document that the repair has been performed.

Motorcycles that are affected must not be sold or operated until the new fuel tank and fuel level sensor, fuel pump, and fuel tank insert gaskets have been installed as described in this bulletin. It is also necessary to reflash the dashboard for proper fuel level calibration. It is a violation of Husqvarna Motorcycles North America, Inc. policy for an authorized Husqvarna Motorcycles Dealer to deliver any affected units to customers before the procedure in this bulletin has been performed.

Husqvarna Motorcycles North America, Inc. must report to the federal government on a regular basis how many units have been inspected and repaired during this campaign. Be sure to submit your warranty request for reimbursement on every unit repaired to ensure accurate compliance numbers.

COPYRIGHT NOTICE

The user acknowledges that all components of this technical information are Husqvarna's and/or third parties' copyright protected property. Alteration, assignment, distribution and reproduction are forbidden.

LIMITATION OF LIABILITY

The information included in or available through this technical information may include inaccuracies or errors. In no event shall Husqvarna and/or its suppliers be liable for any damages whatsoever, arising out of or in connection with the use of this technical information. Please always refer to the Husqvarna owners and repair manuals for proper instructions or contact the Husqvarna Dealer Services Department. ©2020 Husqvarna Motorcycles North America, Inc. – All rights reserved

HUSQVARNA TECHNICAL BULLETIN HTB2012

JULY 2, 2020

PROCEDURE FOR REPAIR:

Disassembly instructions

1. Remove the rider and passenger seat.
2. Remove the black cover and the fuel cap by removing the screws shown in the photo below (Figure 1).



Fig. 1

3. Remove the tank bolt and the two bolts that hold on the side tank covers (Figure 2).



Fig. 2

COPYRIGHT NOTICE

The user acknowledges that all components of this technical information are Husqvarna's and/or third parties' copyright protected property. Alteration, assignment, distribution and reproduction are forbidden.

LIMITATION OF LIABILITY

The information included in or available through this technical information may include inaccuracies or errors. In no event shall Husqvarna and/or its suppliers be liable for any damages whatsoever, arising out of or in connection with the use of this technical information. Please always refer to the Husqvarna owners and repair manuals for proper instructions or contact the Husqvarna Dealer Services Department. ©2020 Husqvarna Motorcycles North America, Inc. – All rights reserved

HUSQVARNA TECHNICAL BULLETIN HTB2012

JULY 2, 2020

4. Remove the five bolts that hold on the tank covers to the tank. Once the bolts are removed slide the cover up to detach it from the side cover. Remove both the right and left side covers (Figure 3).

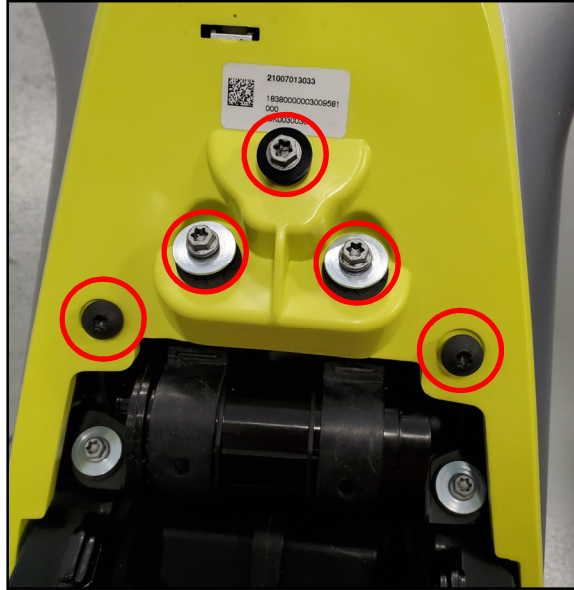

Fig. 3

5. Remove the charcoal canister from its mount and remove the three tank mounting bolts (Figure 4).

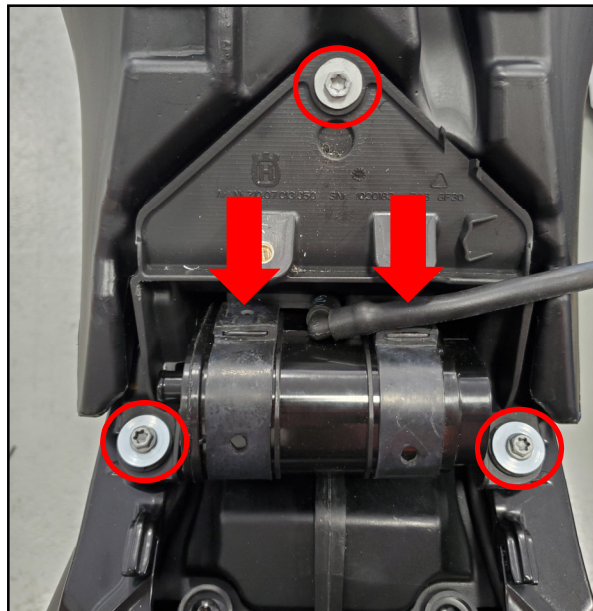

Fig. 4

COPYRIGHT NOTICE

The user acknowledges that all components of this technical information are Husqvarna's and/or third parties' copyright protected property. Alteration, assignment, distribution and reproduction are forbidden.

LIMITATION OF LIABILITY

The information included in or available through this technical information may include inaccuracies or errors. In no event shall Husqvarna and/or its suppliers be liable for any damages whatsoever, arising out of or in connection with the use of this technical information. Please always refer to the Husqvarna owners and repair manuals for proper instructions or contact the Husqvarna Dealer Services Department. ©2020 Husqvarna Motorcycles North America, Inc. – All rights reserved

HUSQVARNA TECHNICAL BULLETIN HTB2012

JULY 2, 2020

6. Disconnect both the fuel pump connector and the fuel level sensor connector. Both connectors are on the right side of the motorcycle.
7. Disconnect the fuel line. Use caution when disconnecting it as a small amount of fuel may leak out. It's advised to use rags to prevent fuel from spilling.
8. Once the tank is removed drain the remaining fuel from the tank using a suitable container. Remove the tank insert, fuel level sensor, fuel pump, and rear tank mounting bracket.

Reassembly instructions

9. Install the rear tank mounting bracket on the new updated tank and torque the bolts to 6 Nm (Figure 5).

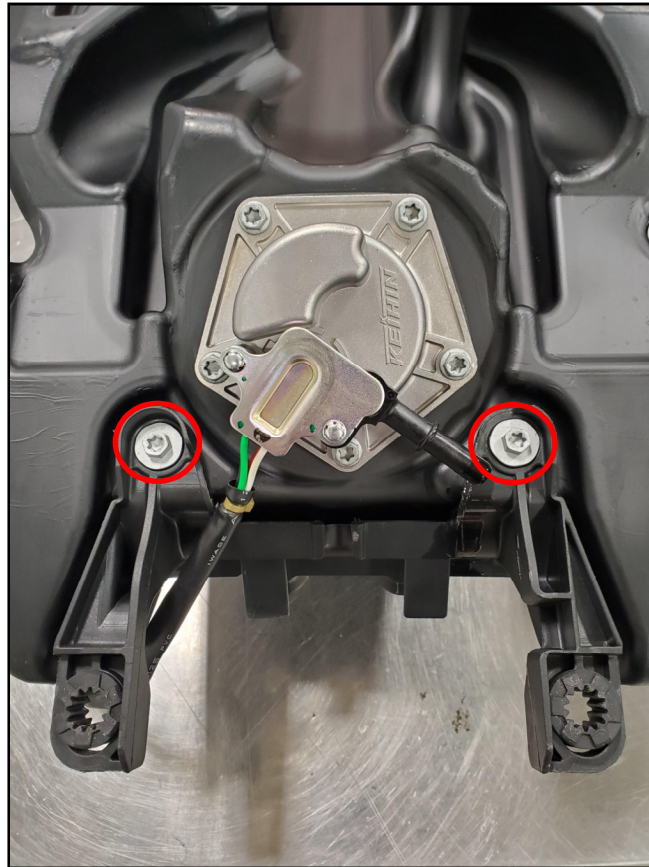

Fig. 5

COPYRIGHT NOTICE

The user acknowledges that all components of this technical information are Husqvarna's and/or third parties' copyright protected property. Alteration, assignment, distribution and reproduction are forbidden.

LIMITATION OF LIABILITY

The information included in or available through this technical information may include inaccuracies or errors. In no event shall Husqvarna and/or its suppliers be liable for any damages whatsoever, arising out of or in connection with the use of this technical information. Please always refer to the Husqvarna owners and repair manuals for proper instructions or contact the Husqvarna Dealer Services Department. ©2020 Husqvarna Motorcycles North America, Inc. – All rights reserved

HUSQVARNA TECHNICAL BULLETIN HTB2012

JULY 2, 2020

10. Make sure to use the new gaskets that you ordered when installing the fuel level sensor, fuel pump, and fuel tank insert (Figure 6 and Figure 7).

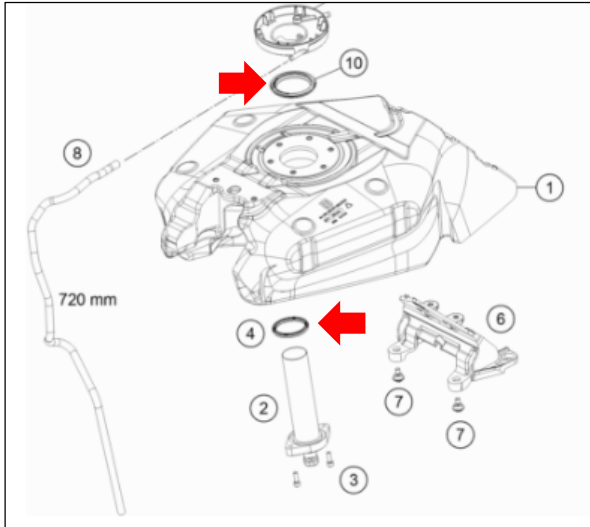

Fig. 6

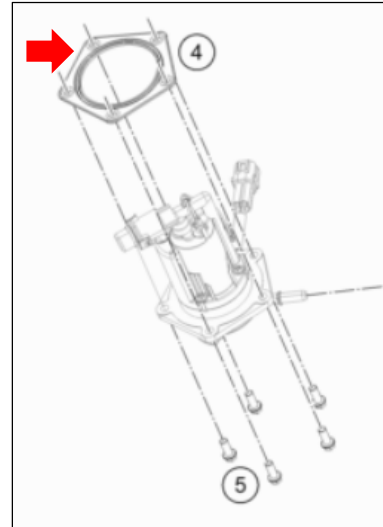

Fig. 7

11. When installing the new gaskets please follow the instructions carefully so the gaskets are installed in the proper manner. Please refer to pages 7, 8 and, 9.

COPYRIGHT NOTICE

The user acknowledges that all components of this technical information are Husqvarna's and/or third parties' copyright protected property. Alteration, assignment, distribution and reproduction are forbidden.

LIMITATION OF LIABILITY

The information included in or available through this technical information may include inaccuracies or errors. In no event shall Husqvarna and/or its suppliers be liable for any damages whatsoever, arising out of or in connection with the use of this technical information. Please always refer to the Husqvarna owners and repair manuals for proper instructions or contact the Husqvarna Dealer Services Department. ©2020 Husqvarna Motorcycles North America, Inc. – All rights reserved

HUSQVARNA TECHNICAL BULLETIN HTB2012

JULY 2, 2020

12. Position the gasket on the fuel tank insert as shown in (Figure 8). The flat side of the gasket faces towards the insert. The rounded tapered side of the gasket faces towards the fuel tank (red arrow).



Fig. 8

13. Then install the fuel tank insert and torque the bolts to 3 Nm (Figure 9).

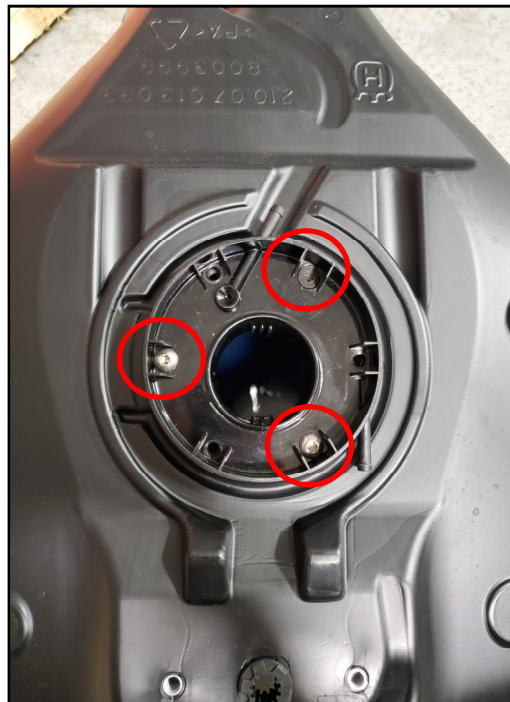

Fig. 9

COPYRIGHT NOTICE

The user acknowledges that all components of this technical information are Husqvarna's and/or third parties' copyright protected property. Alteration, assignment, distribution and reproduction are forbidden.

LIMITATION OF LIABILITY

The information included in or available through this technical information may include inaccuracies or errors. In no event shall Husqvarna and/or its suppliers be liable for any damages whatsoever, arising out of or in connection with the use of this technical information. Please always refer to the Husqvarna owners and repair manuals for proper instructions or contact the Husqvarna Dealer Services Department. ©2020 Husqvarna Motorcycles North America, Inc. – All rights reserved

HUSQVARNA TECHNICAL BULLETIN HTB2012

JULY 2, 2020

14. Install the fuel level sensor and torque the bolts 3 Nm. The gasket must be installed so the open side of the gasket faces towards the sensor and the closed rounded side faces towards the tank (Figure 10).

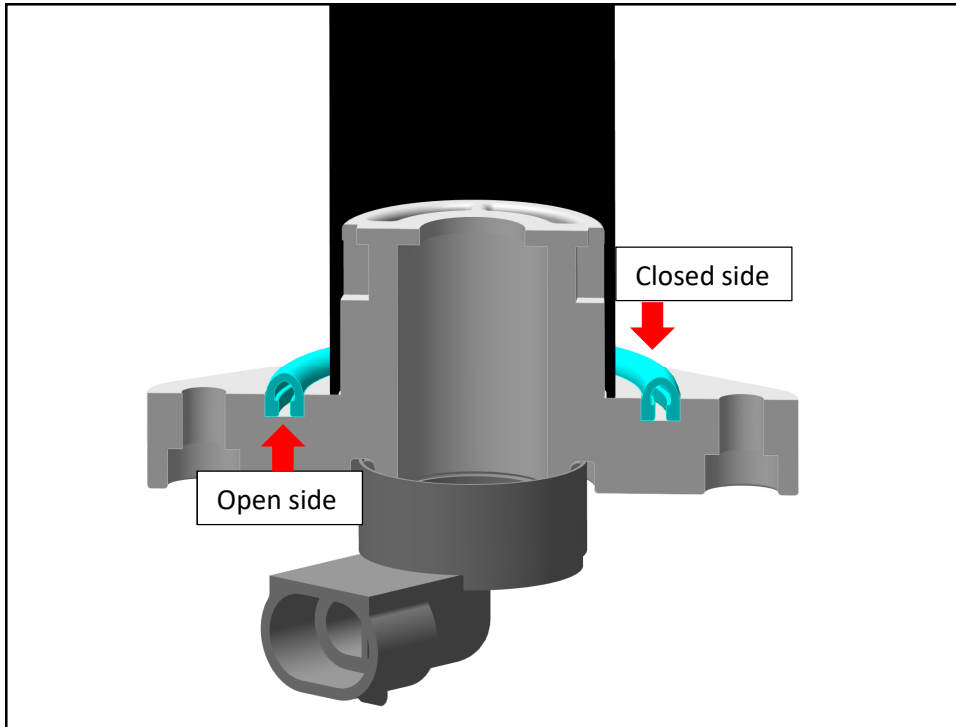

Fig. 10

COPYRIGHT NOTICE

The user acknowledges that all components of this technical information are Husqvarna's and/or third parties' copyright protected property. Alteration, assignment, distribution and reproduction are forbidden.

LIMITATION OF LIABILITY

The information included in or available through this technical information may include inaccuracies or errors. In no event shall Husqvarna and/or its suppliers be liable for any damages whatsoever, arising out of or in connection with the use of this technical information. Please always refer to the Husqvarna owners and repair manuals for proper instructions or contact the Husqvarna Dealer Services Department. ©2020 Husqvarna Motorcycles North America, Inc. – All rights reserved

HUSQVARNA TECHNICAL BULLETIN HTB2012

JULY 2, 2020

15. The fuel pump gasket must be installed carefully by following the pictures shown below. Make sure the silver inserts (circled in red) in the gasket face down towards the fuel pump flange (Figure 11). The gasket can only be installed one correct way, the gasket has a small tab that needs to be located with the bolt hole in between the fuel outlet and the fuel pump wiring (boxed in green) (Figure 12). This is the only way the fuel pump gasket can be installed for proper sealing.

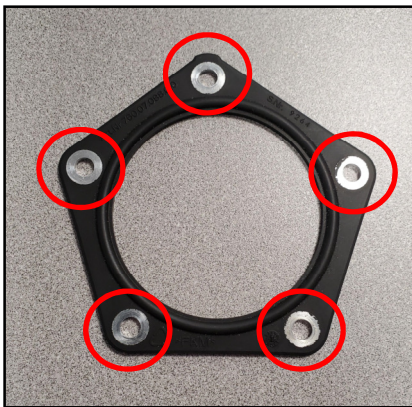

Fig. 11

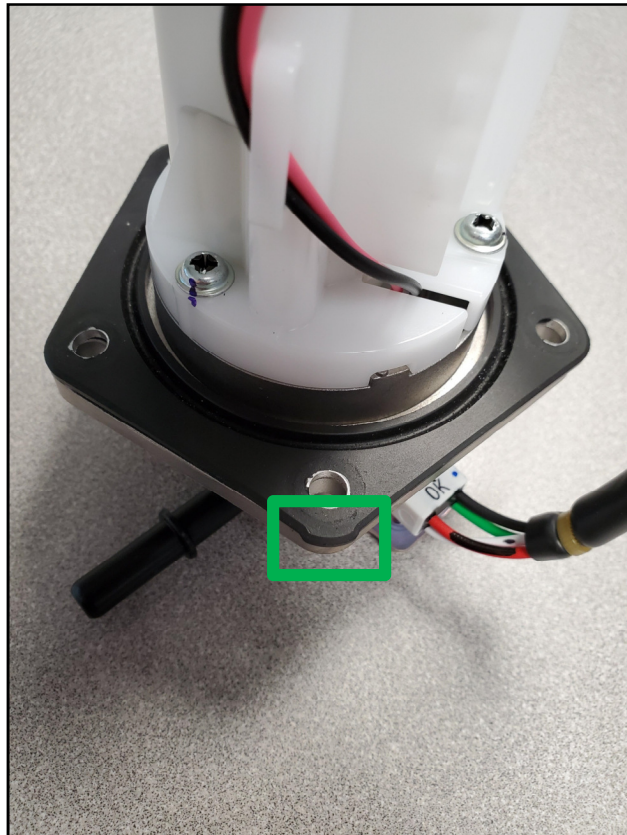

Fig. 12

COPYRIGHT NOTICE

The user acknowledges that all components of this technical information are Husqvarna's and/or third parties' copyright protected property. Alteration, assignment, distribution and reproduction are forbidden.

LIMITATION OF LIABILITY

The information included in or available through this technical information may include inaccuracies or errors. In no event shall Husqvarna and/or its suppliers be liable for any damages whatsoever, arising out of or in connection with the use of this technical information. Please always refer to the Husqvarna owners and repair manuals for proper instructions or contact the Husqvarna Dealer Services Department. ©2020 Husqvarna Motorcycles North America, Inc. – All rights reserved

HUSQVARNA TECHNICAL BULLETIN HTB2012

JULY 2, 2020

16. Install the fuel pump and use a crisscross pattern when installing bolts and torquing them. Use the crisscross pattern shown in (Figure 13). Tighten the bolts in two steps. First tighten the bolts to 3 Nm in the crisscross pattern. Then tighten them again a second time in the crisscross pattern and torque the bolts to 6 Nm to tighten them to their final torque specification.

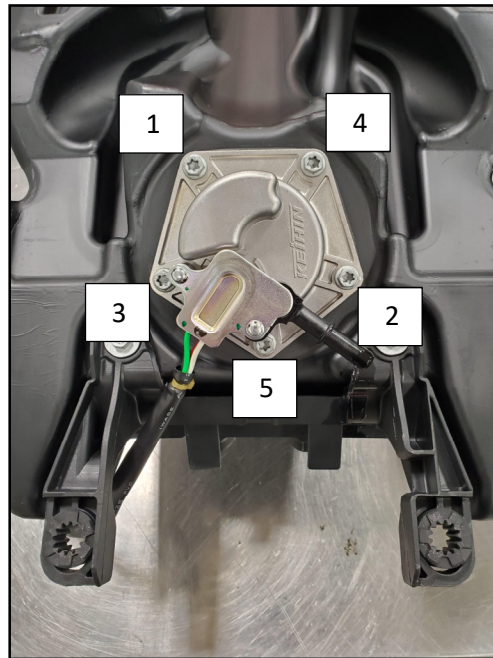

Fig. 13

17. Mount the new fuel tank on the motorcycle and connect the fuel line, fuel pump, and fuel level sensor. Torque the fuel tank mounting bolts to 10 Nm (Figure 14).

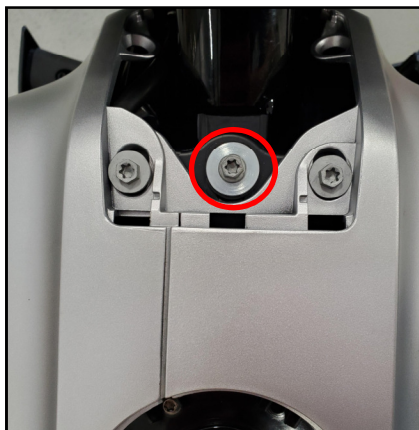

Fig. 14

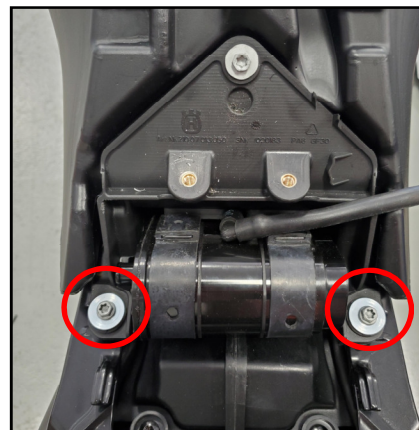

Fig. 15

18. Install the charcoal canister to mounting the bracket and connect the fuel cap vent lines (Figure 15).

COPYRIGHT NOTICE

The user acknowledges that all components of this technical information are Husqvarna's and/or third parties' copyright protected property. Alteration, assignment, distribution and reproduction are forbidden.

LIMITATION OF LIABILITY

The information included in or available through this technical information may include inaccuracies or errors. In no event shall Husqvarna and/or its suppliers be liable for any damages whatsoever, arising out of or in connection with the use of this technical information. Please always refer to the Husqvarna owners and repair manuals for proper instructions or contact the Husqvarna Dealer Services Department. ©2020 Husqvarna Motorcycles North America, Inc. – All rights reserved

HUSQVARNA TECHNICAL BULLETIN HTB2012

JULY 2, 2020

19. Install both side tank covers and torque the front bolts to 3 Nm (Figure 16).



Fig. 16

20. Slide the rear tank cover down from the top and install the mounting bolts to 3 Nm (Figure 17).

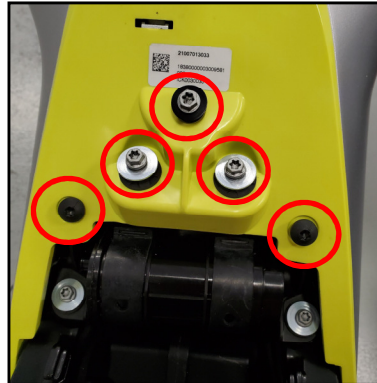

Fig. 17

21. Install the black cover and the fuel cap and torque bolts to 3 Nm (Figure 18).



Fig. 18

COPYRIGHT NOTICE

The user acknowledges that all components of this technical information are Husqvarna's and/or third parties' copyright protected property. Alteration, assignment, distribution and reproduction are forbidden.

LIMITATION OF LIABILITY

The information included in or available through this technical information may include inaccuracies or errors. In no event shall Husqvarna and/or its suppliers be liable for any damages whatsoever, arising out of or in connection with the use of this technical information. Please always refer to the Husqvarna owners and repair manuals for proper instructions or contact the Husqvarna Dealer Services Department. ©2020 Husqvarna Motorcycles North America, Inc. – All rights reserved

HUSQVARNA TECHNICAL BULLETIN HTB2012

JULY 2, 2020

22. Connect the motorcycle to the XC_2 tool and update the instrument panel cluster software to the latest version available. This is necessary to reflash the dashboard for proper fuel level calibration. The new software version is **DAKT_285H100A124.s19**
23. Put fuel in the motorcycle and check for leaks.
24. Perform a test ride.
25. Take a picture of the tank part number and date code shown below so you can attach the photo to the warranty claim. Also cut out the date code which is circled below using a rotary cutting tool or similar cutting tool (Figure 19).

Please return the date code that you cut out of the original fuel tank. Place it in a bag and write the VIN and claim number on the bag. Send the cut out date code to the Husqvarna Motorcycles North America, Inc. Warranty Department at 1119 Milan Ave. Amherst, OH 44001.

Warranty Claims will only be processed after the cut out date code has been received. Parts must be bagged and include a copy of the claim.

If you need additional labels please order using the following part number:
FedEx Prepaid Return Label p.n. UH999094



Fig. 19

COPYRIGHT NOTICE

The user acknowledges that all components of this technical information are Husqvarna's and/or third parties' copyright protected property. Alteration, assignment, distribution and reproduction are forbidden.

LIMITATION OF LIABILITY

The information included in or available through this technical information may include inaccuracies or errors. In no event shall Husqvarna and/or its suppliers be liable for any damages whatsoever, arising out of or in connection with the use of this technical information. Please always refer to the Husqvarna owners and repair manuals for proper instructions or contact the Husqvarna Dealer Services Department. ©2020 Husqvarna Motorcycles North America, Inc. – All rights reserved



HUSQVARNA TECHNICAL BULLETIN HTB2012

JULY 2, 2020

Table 1 - Screw connections and torques

Component	Screw	Torque	Remark
Tank fastener screw	M6	10 Nm	
Screw, fuel level sensor	M5	3 Nm	
Screw, fuel tank cap	M5x30	3 Nm	
Screw, fuel tank insert	M5x12	3 Nm	
Bushing, fuel tank spoiler	M6	3 Nm	
Screw, fuel pump	M6	6 Nm	Attach screws, tighten in a crisscross pattern. First tighten to 3 Nm then tighten to their final torque specification of 6 Nm.
Screw, fuel tank spoiler	M6	3 Nm	

PARTS ORDERING:

Order the following parts for each affected motorcycle. You must order all parts shown below to complete this recall properly.

- 1 QTY. 21007013100 – fuel tank
- 1 QTY. 21007008151 – gasket, tank insert
- 1 QTY. 76007080190 – gasket, fuel level sensor
- 1 QTY. 76007088010 – gasket, fuel pump

VEHICLE LOCK INFORMATION:

Unsold motorcycles that are linked to this recall are locked in the vehicle history. The vehicle lock prevents the motorcycle from being retailed to a customer before the recall is performed. In order to unlock the vehicle you must perform the recall and then submit a TI claim. After the TI claim is submitted it will be possible to unlock and retail the motorcycle.

COPYRIGHT NOTICE

The user acknowledges that all components of this technical information are Husqvarna's and/or third parties' copyright protected property. Alteration, assignment, distribution and reproduction are forbidden.

LIMITATION OF LIABILITY

The information included in or available through this technical information may include inaccuracies or errors. In no event shall Husqvarna and/or its suppliers be liable for any damages whatsoever, arising out of or in connection with the use of this technical information. Please always refer to the Husqvarna owners and repair manuals for proper instructions or contact the Husqvarna Dealer Services Department. ©2020 Husqvarna Motorcycles North America, Inc. – All rights reserved



HUSQVARNA TECHNICAL BULLETIN HTB2012

JULY 2, 2020

WARRANTY INPUT INFORMATION:

This Technical Bulletin only affects certain VIN numbers! Please check the VIN by performing a Motorcycle History search in Husqvarna Dealer.net to determine if it's affected. If the motorcycle is affected you will see a link to the bulletin and its repair status in the history results. Husqvarna Motorcycles North America, Inc. will not warranty units whose VIN numbers are not listed as this bulletin does not apply to them. It is the responsibility of the dealer to determine if the unit requires this update by checking the vehicle history and understanding the instructions provided by this bulletin.

Please note that when entering a warranty claim on an affected model, you must perform a history search, expand the **Technical Information** window, click the blue arrow on the right side of the corresponding bulletin message.

You can now choose the TI Number from the list. The TI number for this procedure is according to the repairs performed and listed in the warranty claim input information; click **Continue with selected action code**.

The Warranty Claim is automatically entered for you, including parts & labor. You must enter additional information in the required fields marked with an asterisk "*" before submitting the claim to Husqvarna Motorcycles. The flat rate time for this repair is based on the action performed and provided in minutes.

Warranty type:
TI warranty
Component group:
07 – Fuel tank, seat, spoiler
Failure code:
700 – Series improvement
Failure causing part:
21007013000 – Fuel tank
Campaign code, parts, labor time:
Replacement of fuel tank
Action code: 07_1776254_00
Labor time: 55 minutes
Parts:
1 QTY. 21007013100 – fuel tank
1 QTY. 21007008151 – gasket, tank insert
1 QTY. 76007080190 – gasket, fuel level sensor
1 QTY. 76007088010 – gasket, fuel pump
Are stock items affected:
Yes

COPYRIGHT NOTICE

The user acknowledges that all components of this technical information are Husqvarna's and/or third parties' copyright protected property. Alteration, assignment, distribution and reproduction are forbidden.

LIMITATION OF LIABILITY

The information included in or available through this technical information may include inaccuracies or errors. In no event shall Husqvarna and/or its suppliers be liable for any damages whatsoever, arising out of or in connection with the use of this technical information. Please always refer to the Husqvarna owners and repair manuals for proper instructions or contact the Husqvarna Dealer Services Department. ©2020 Husqvarna Motorcycles North America, Inc. – All rights reserved

HUSQVARNA TECHNICAL BULLETIN HTB2012

JULY 2, 2020

IMPORTANT SAFETY RECALL NOTICE NHTSA Recall No. xxxxxxxx

Affected VIN: «Vin»
«PdiFirstName» «PdiLastName»
«PdiAddress1»
«PdiCity», «PdiProvince» «PdiPostalCode»

x/xx/2020

RE: Affected models:
2018, 2019, 2020 – VITPILEN 701
2019, 2020 – SVARTPILEN 701

Dear Husqvarna Motorcycles Customer,

This notice is sent to you in accordance with the requirements of the National Traffic and Motor Vehicle Safety Act. Husqvarna Motorcycles North America, Inc. has decided that a defect which relates to motor vehicle safety exists with the motorcycle models and years listed above. On affected motorcycles, during operation or while sitting still it is possible that fuel can seep or leak out of the fuel level sensor mounting area and fuel pump mounting area. The presence of a leak could result in the possibility of damage or possible fire, which could cause injury or death to the rider or others.

To ensure the highest level of safety, performance, reliability and customer satisfaction, it is necessary to have a newly developed fuel tank along with new gaskets for the fuel level sensor, fuel pump and fuel tank insert installed. A new flash file will also need to be downloaded and updated into the dashboard for proper fuel calibration. This work must be performed by an authorized Husqvarna Motorcycles dealer and will be done free of charge.

Husqvarna Motorcycles North America, Inc. previously sent you a letter dated 4/8/2020 advising that it is possible that fuel can seep or leak out of the fuel level sensor mounting area and fuel pump mounting area and was being investigated by Husqvarna Motorcycles. At that time a remedy was in the process of being determined.

The cause of the defect is due to the sealing design of the current version fuel tank. It does not allow for proper sealing between the fuel tank and fuel level sensor mounting area and fuel pump mounting area. To remedy this defect, a new fuel tank with thicker walls has been developed to install on the motorcycle to prevent fuel leakage. The thicker tank walls prevent unevenness at the fuel level sensor mounting area and fuel pump mounting area and improve sealing behavior. The increased wall thickness reduces the tank volume by approximately 0.8 liters. The total fuel tank capacity of the new fuel tank is approximately 11.2 liters.

Please contact your authorized Husqvarna Motorcycles dealer (log onto www.husqvarna-motorcycles.com for a complete dealer listing) as soon as possible to arrange for installation of the replacement new fuel tank and gaskets. It is suggested that you call your local authorized Husqvarna Motorcycles dealer to make an appointment to have the recall repair performed. The replacement procedure will take approximately 1.0 hour. However, it may be necessary to leave your motorcycle with the dealer for a longer period of time depending on their work schedule. Please present a copy of this letter along with your motorcycle to your local authorized Husqvarna Motorcycles dealer. There will be no charge for this service.

If you have any questions related to the content of this letter, please contact Husqvarna Motorcycles North America, Inc. Customer Relations at (888) 985-6090 for assistance. Furthermore, if you believe that Husqvarna Motorcycles has failed to remedy this defect without charge or is unable to do so within a reasonable time, you may submit a complaint to the Administrator, National Highway Traffic Safety Administration, 1200 New Jersey Avenue, S.E., Washington, DC 20590 or call 1-888-327-4236 (TTY: 1-800-424-9153); or go to <http://www.safercar.gov>

COPYRIGHT NOTICE

The user acknowledges that all components of this technical information are Husqvarna's and/or third parties' copyright protected property. Alteration, assignment, distribution and reproduction are forbidden.

LIMITATION OF LIABILITY

The information included in or available through this technical information may include inaccuracies or errors. In no event shall Husqvarna and/or its suppliers be liable for any damages whatsoever, arising out of or in connection with the use of this technical information. Please always refer to the Husqvarna owners and repair manuals for proper instructions or contact the Husqvarna Dealer Services Department. ©2020 Husqvarna Motorcycles North America, Inc. – All rights reserved



If you have sold, traded or no longer own this motorcycle, it is important for the safety of the current owner that you inform Husqvarna Motorcycles North America, Inc., of current ownership or unknown ownership status by returning the second page of this letter in the enclosed self-addressed prepaid postage envelope.

Federal law requires that any vehicle lessor receiving this recall notice must forward a copy of this notice to the lessee within 10 days.

We apologize for any inconvenience and want to assure you that our commitment together with all Husqvarna Motorcycles Dealers is to provide you with the highest level of service, support and customer satisfaction.

Best Regards,
Dealer Services Department
Husqvarna Motorcycles North America, Inc.

Customer Record Update Form

NOTICE: If you no longer own this motorcycle or have had an address change please complete the following portion of this letter and return to Husqvarna Motorcycles in the enclosed self-addressed envelope.

Please complete and return this portion to Husqvarna Motorcycles if ownership of the referenced motorcycle has changed. Please print legibly.

The new address is or I have sold the motorcycle to:

New owner's name _____	«Vin»
Address _____	«PdiFirstName» «PdiLastName»
City _____ State _____ Zip _____	«PdiAddress1»
Phone number _____	«PdiCity»,«PdiProvince» «PdiPostalCode»
Email _____	
Date of Resale _____	

Returning this form will help us to contact the current owner and will enable us to update our records so you can be assured not to receive notifications for this motorcycle in the future. Thank you.

COPYRIGHT NOTICE

The user acknowledges that all components of this technical information are Husqvarna's and/or third parties' copyright protected property. Alteration, assignment, distribution and reproduction are forbidden.

LIMITATION OF LIABILITY

The information included in or available through this technical information may include inaccuracies or errors. In no event shall Husqvarna and/or its suppliers be liable for any damages whatsoever, arising out of or in connection with the use of this technical information. Please always refer to the Husqvarna owners and repair manuals for proper instructions or contact the Husqvarna Dealer Services Department. ©2020 Husqvarna Motorcycles North America, Inc. – All rights reserved