

JTBO0585NAS3

TECHNICAL BULLETIN

16 DEC 2020



© Jaguar Land Rover North America, LLC

NOTE: The information in Technical Bulletins is intended for use by trained, professional Technicians with the knowledge, tools, and equipment required to do the job properly and safely. It informs these Technicians of conditions that may occur on some vehicles, or provides information that could assist in proper vehicle service. The procedures should not be performed by 'do-it-yourselfers'. If you are not a Retailer, do not assume that a condition described affects your vehicle. Contact an authorized Jaguar service facility to determine whether this bulletin applies to a specific vehicle.

INFORMATION

This reissue replaces all previous versions. Please destroy all previous versions.

This bulletin supersedes TSB JTBO0585NAS2/2018 dated 12 FEB 2018, which should either be destroyed or clearly marked to show it is no longer valid (e.g. with a line across the page). Only refer to the electronic version of this Technical Bulletin in TOPIx.

Changes are highlighted in blue

SECTION:

418-02

SUBJECT/CONCERN:

Passive Entry System Slow To Unlock

AFFECTED VEHICLE RANGE:

MODEL:	MODEL YEAR:	VIN:	ASSEMBLY PLANT:
XF (X260)	2018	Y53259-Y53224	Castle Bromwich

MARKETS:NORTH AMERICA

CONDITION SUMMARY:**NOTE:**

This bulletin affects XF models that feature passive entry without the soft close function.

SITUATION:

The fast latch operation does not operate and there is a delay upon entry to the vehicle using passive entry.

CAUSE:

Wiring harness design error for 2018 model year passive entry (without soft close) vehicles only.

ACTION:

Follow the instructions below.

PARTS:**NOTES:**

- Repair wires, heatshrink sleeves, and splice connectors can be obtained from the wiring harness repair kit or ordered through your parts department.
- Repair wires, heatshrink sleeves, and splice connectors are supplied in packs of 10.

PART NUMBER	DESCRIPTION	QUANTITY
418279	Repair wire	4
418104	Heatshrink sleeve	4
418107	Splice connector	4
T4N9812	Door trim panel clip	38

TOOLS:

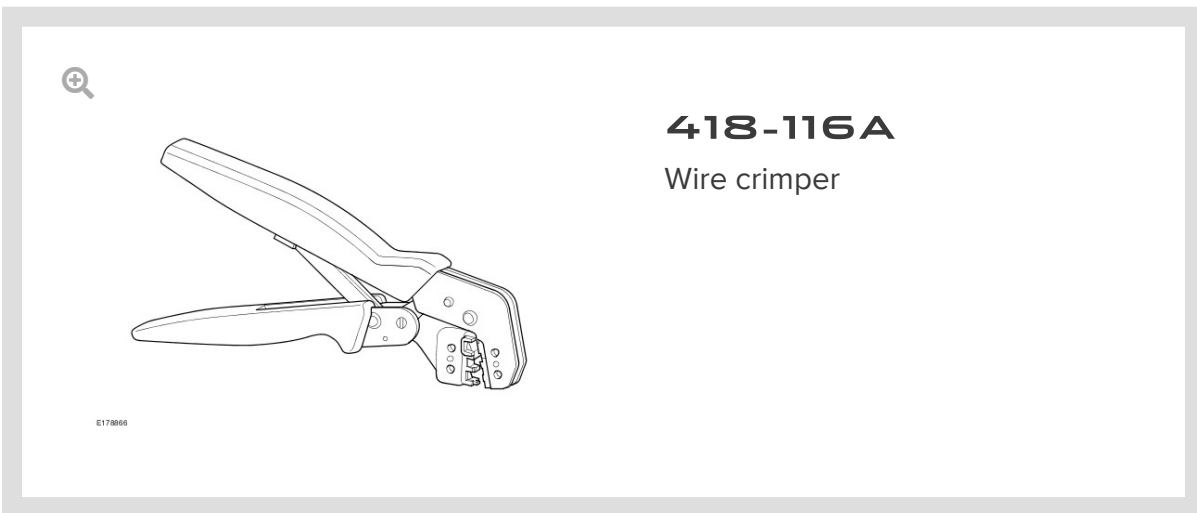
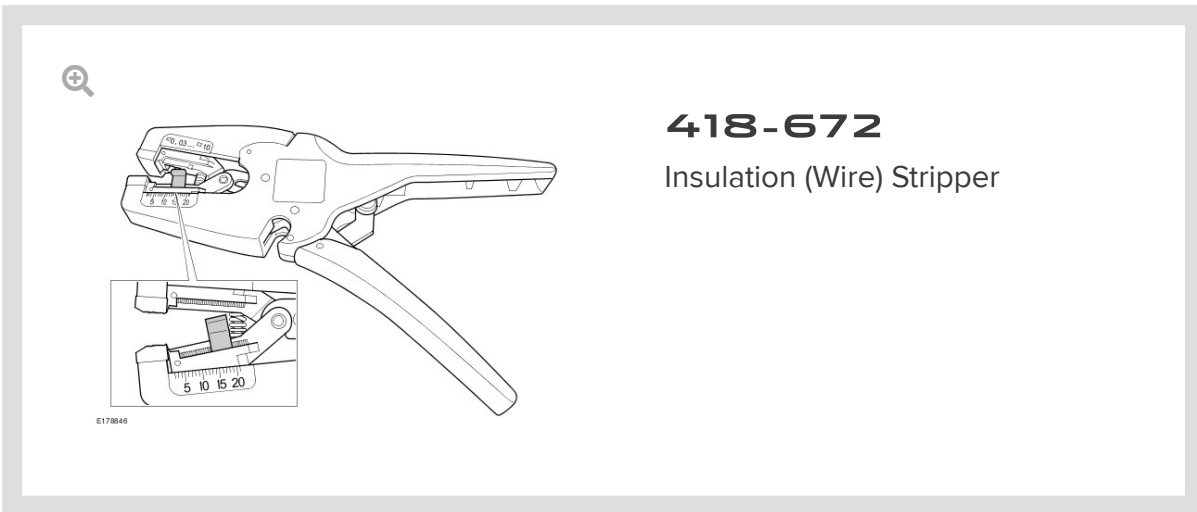

WARRANTY:

NOTES:

- Repair procedures are under constant review, and therefore times are subject to change; those quoted here must be taken as guidance only. Use TOPIx to obtain the latest repair time.
- The JLR claims submission system requires the use of causal part numbers. Labor only claims must show the causal part number with a quantity of zero.

DESCRIPTION	SRO	TIME (HOURS)	CONDITION CODE	CAUSAL PART
-------------	-----	--------------	----------------	-------------

DESCRIPTION	SRO	TIME (HOURS)	CONDITION CODE	CAUSAL PART
Passive entry - Wiring modification	76.96.59	2.6	JU	T2H27766

NOTE:

Normal Warranty procedures apply.

SERVICE INFORMATION:

1. See TOPIx Workshop Manual section **418-02: Wiring harnesses - General procedures - Wiring harness repair** for information on the repair or modification of electrical wiring harnesses.

SERVICE INSTRUCTION 'A' - FRONT RIGHT DOOR**NOTES:**

- Some variation in the illustrations may occur, but the essential information is always correct.
- Removal steps in this procedure may contain installation details.
- Some components shown removed for clarity.

1. Remove the front right door trim panel (see TOPIx Workshop Manual section 501-05: Interior trim and ornamentation - Removal and installation - Front door trim panel).

2.

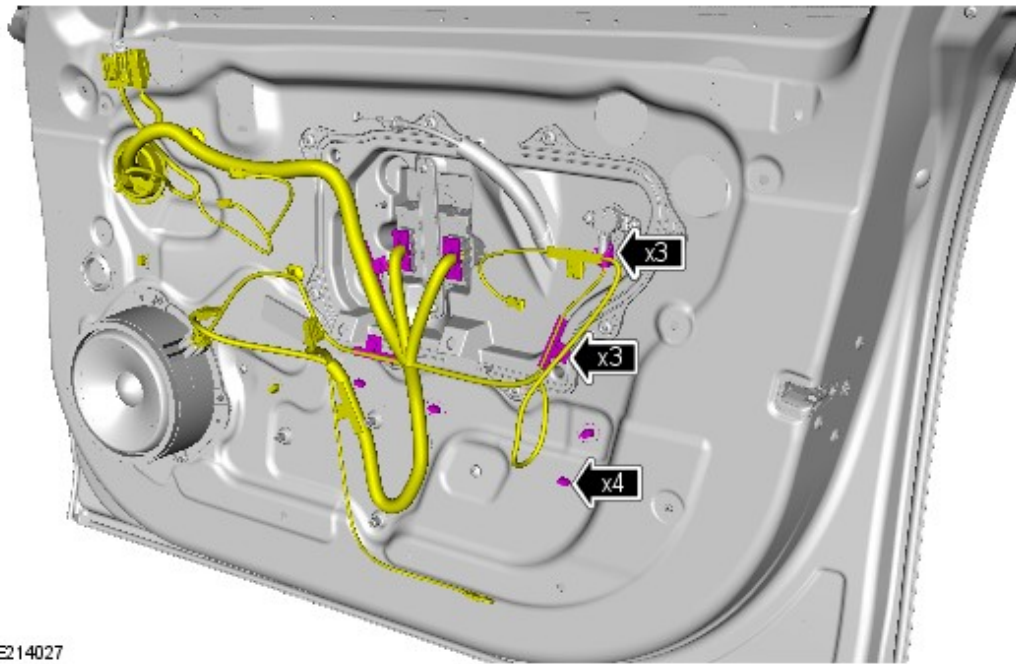

E214027

Disconnect the front right door electrical wiring harness and position to the side.

3.

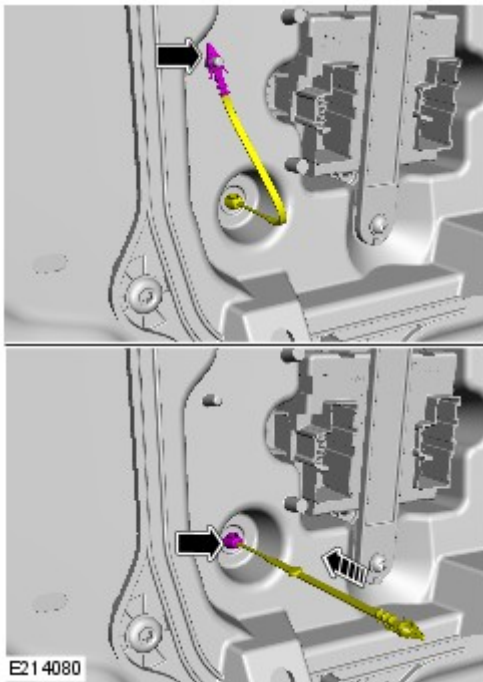

E214080

Remove the door window regulator retaining clip.

4.

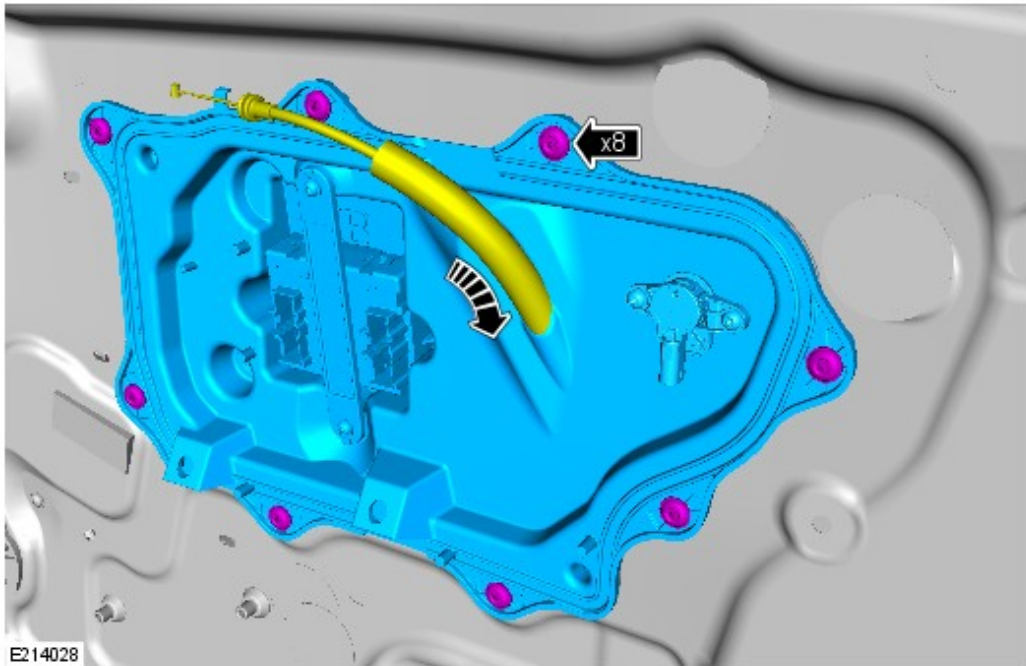

Remove the front right door closing panel.

5.

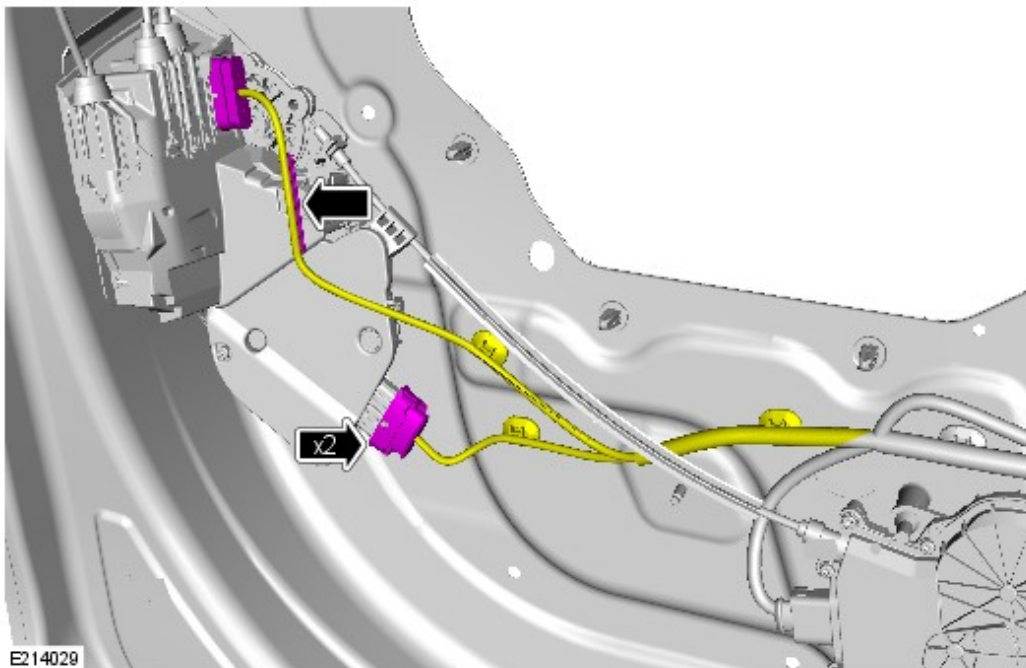

Disconnect the front right door electrical wiring harness from the front right door latch.

- ■ Withdraw the electrical wiring harness from the front right door so it can be modified.

6.

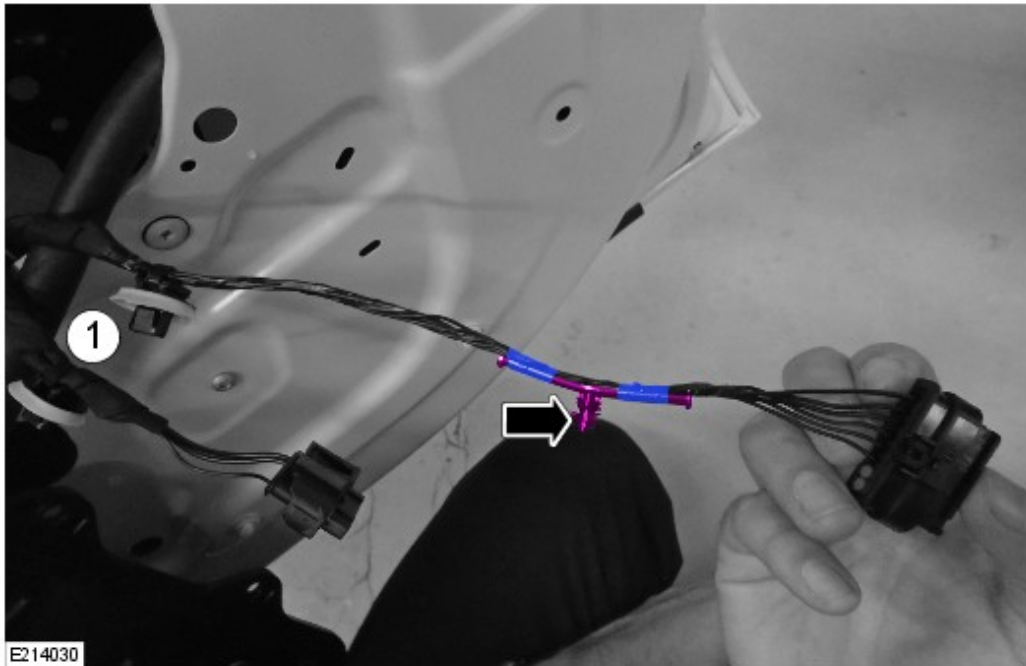

Remove the fir tree clip from the front right door electrical wiring harness.

- ■ Remove the insulation tape from the front right door electrical wiring harness up to the retaining clip **(1)**.

7.

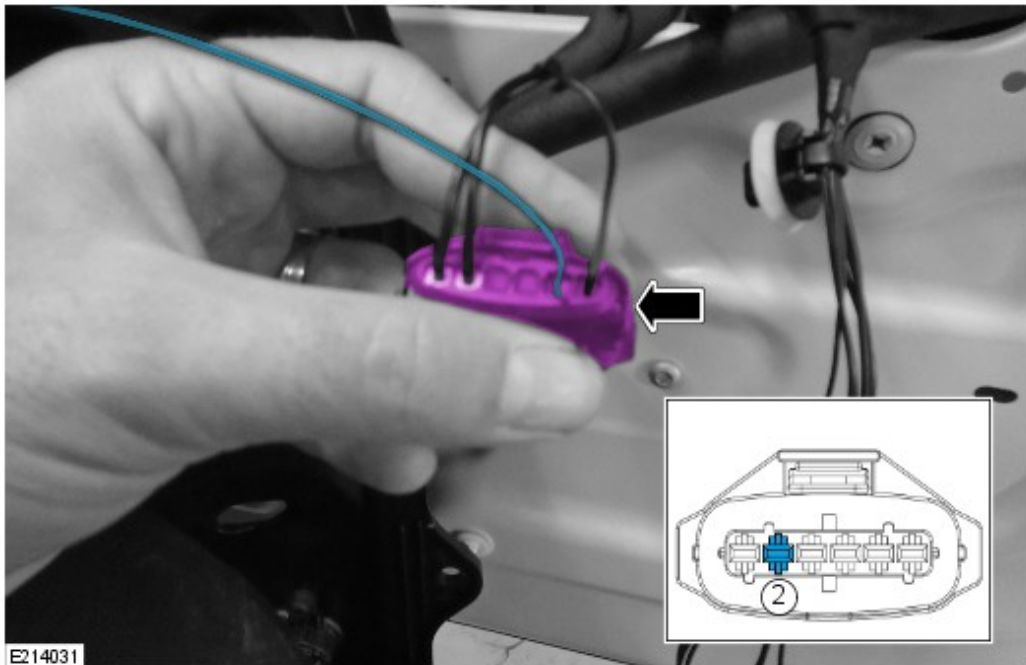

Locate electrical connector **C6PK10** on the front right door electrical wiring harness and remove the sealing grommet from cavity 2.

- **1.** Install the repair wire into cavity 2.

8.

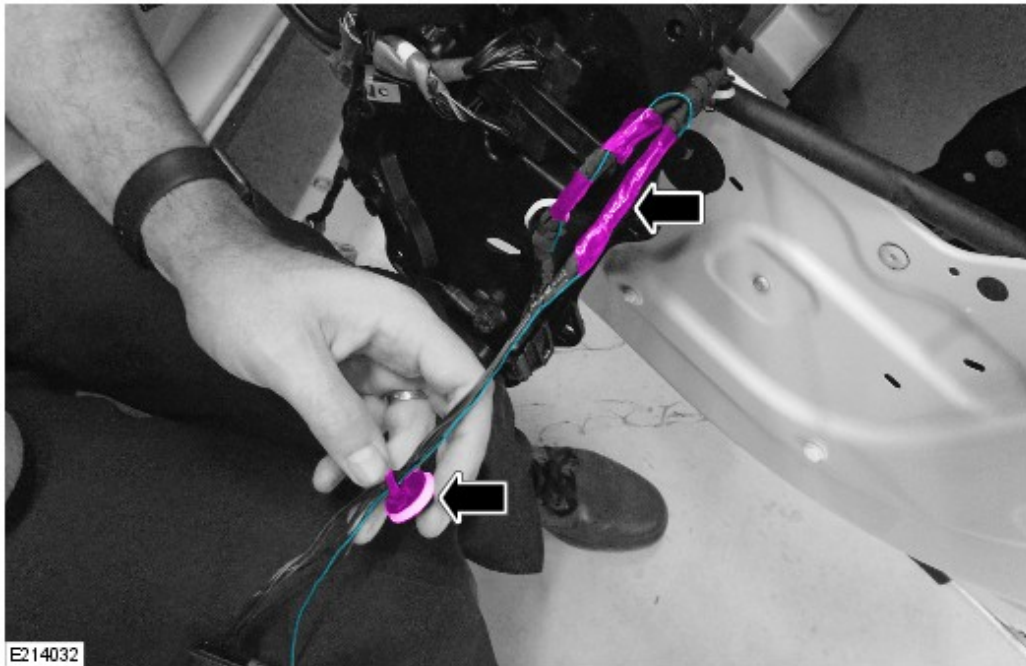

Install the repair wire to the front right door electrical wiring harness with electrical insulation tape as shown.

- **1.** Route the repair wire through the front right door electrical wiring loom retaining clip.

9.

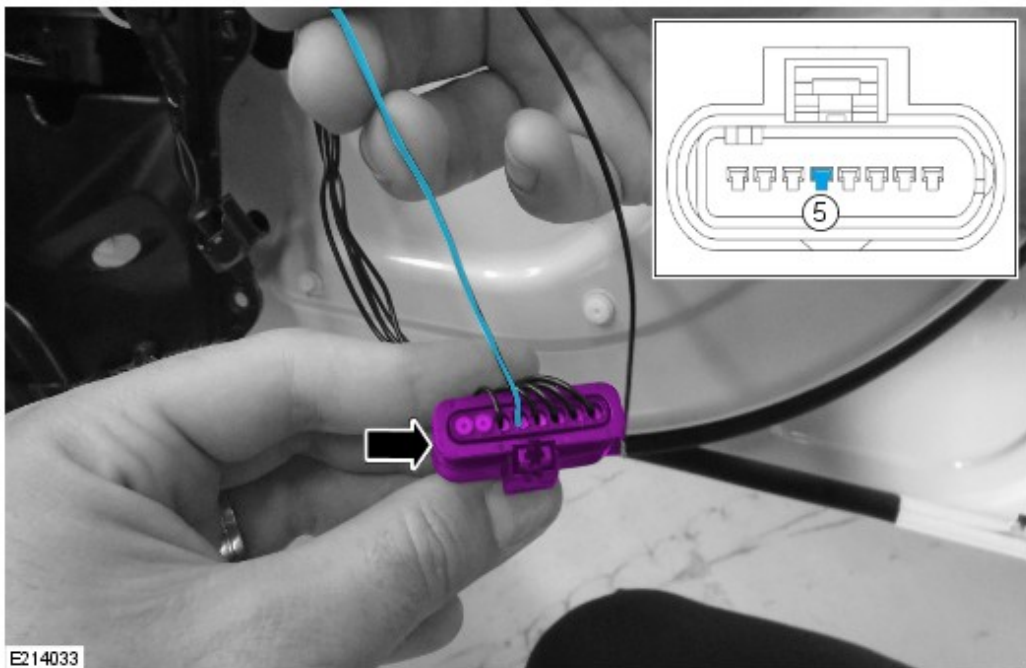

Locate the electrical connector **C6PL64**.

- **1.** Locate the electrical wire in cavity 5.

10.

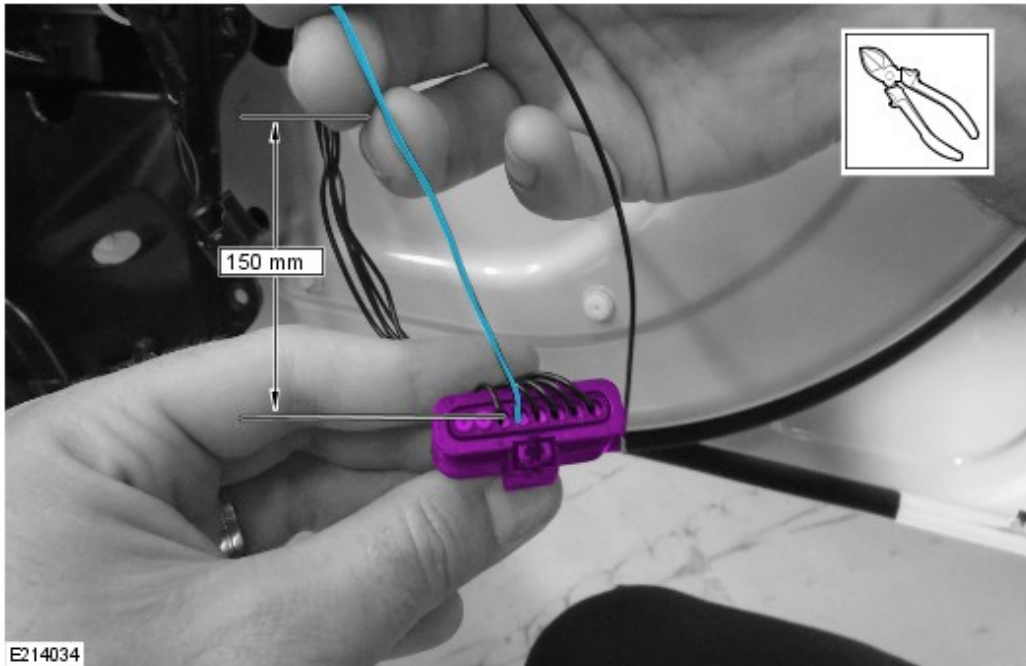

Cut the electrical wire 150 mm from the back of the electrical connector **C6PL64**.

11.

NOTE:

Do not apply heat to the heatshrink at this stage.

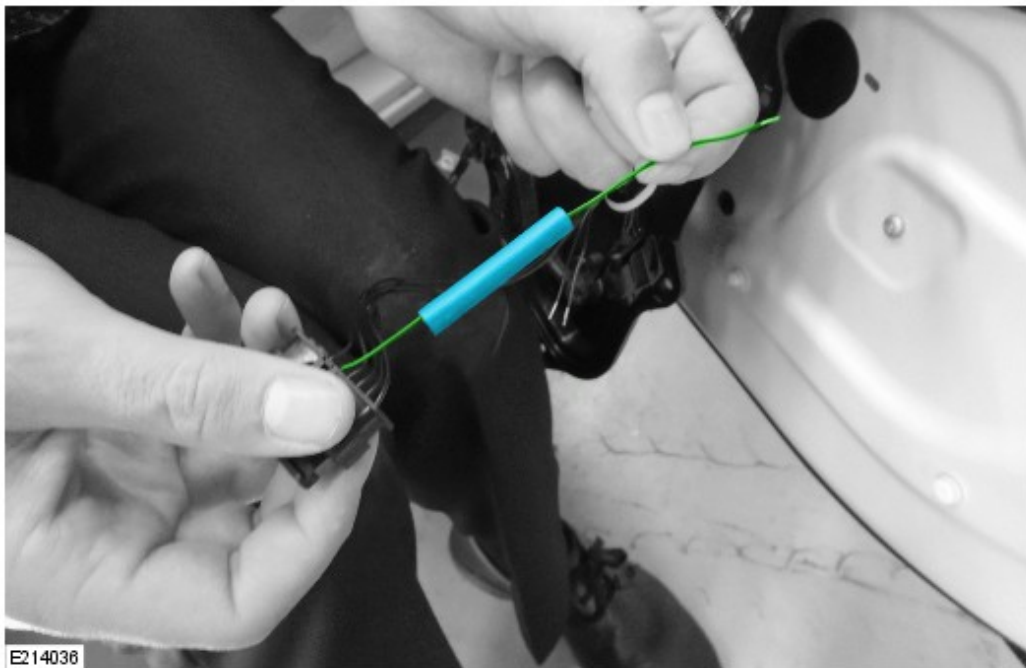

Install a length of heatshrink onto the front right door electrical wiring harness.

12.



Cut the repair wire to a suitable length and prepare the front right door electrical wiring harness for a splice connector.

13.

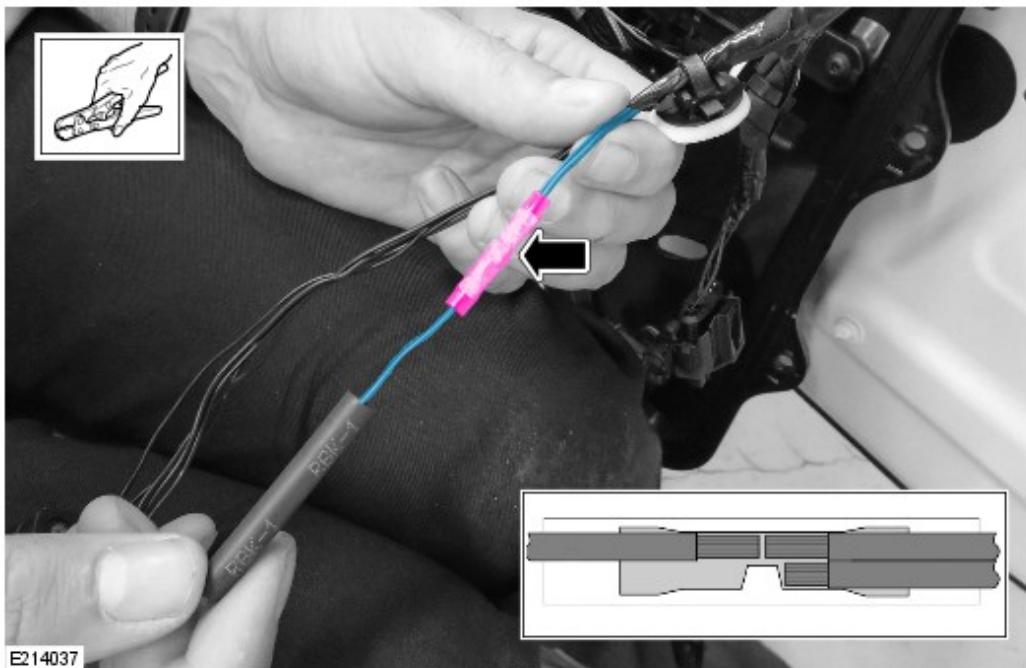

Create a 2-wire splice joint between the front right door electrical wiring harness and the repair wire.

14.

WARNING:

When using a heat source, make sure that it is localized and does not cause damage to the operator or surrounding materials.



Position the heatshrink over the splice connector and apply heat to seal the splice connector.

15.

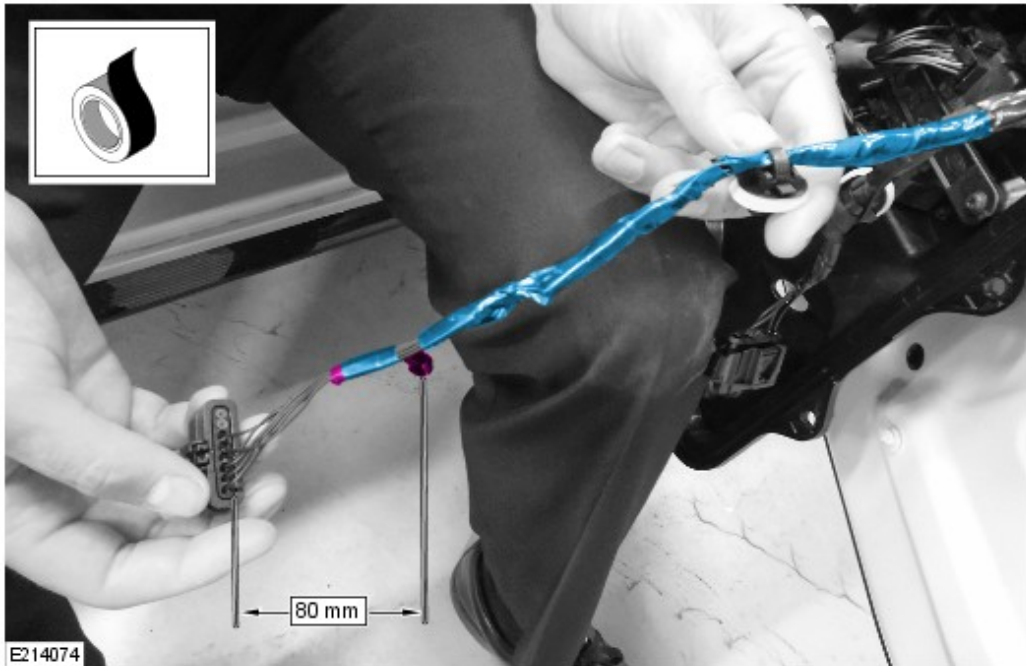

Install the fir tree clip 80 mm from the connector **C6PL64** on the front right door electrical wiring harness.

- 1. Wrap the front right door electrical wiring harness with insulation tape.

16.

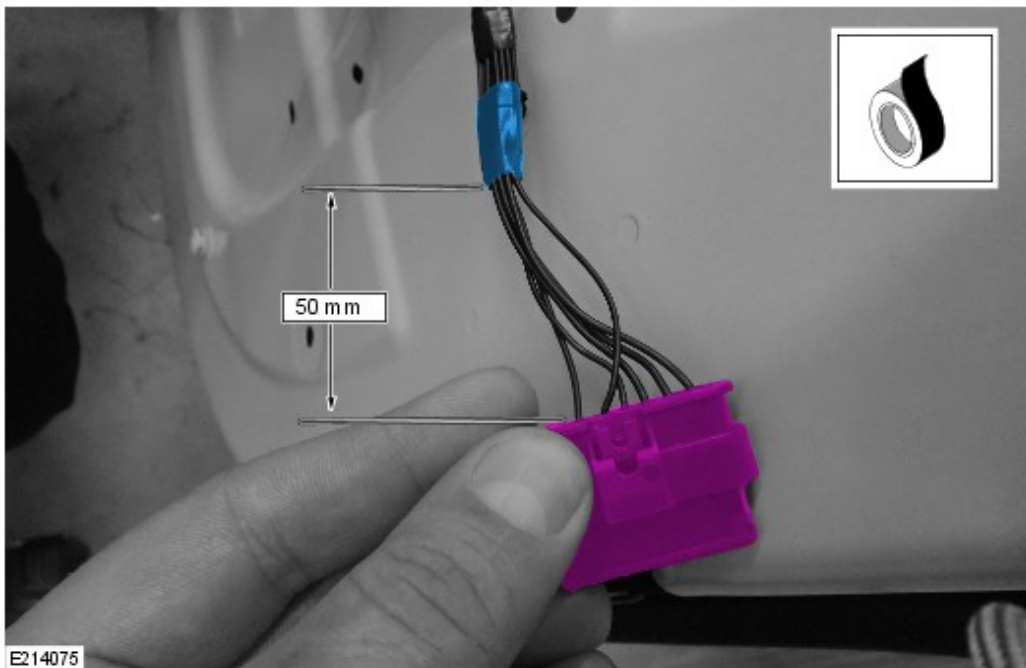

Make sure there is 50 mm clearance between the electrical connector **C6PL64** and the insulation tape.

17.

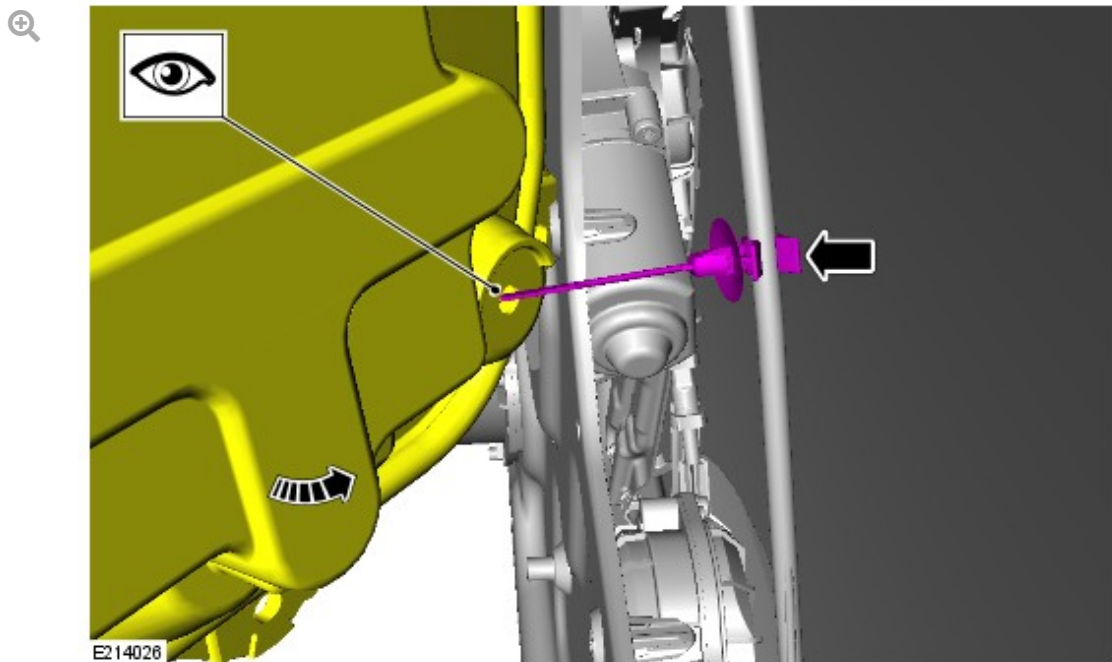

When installing the front right door closing panel, make sure to pass the door window regulator retaining clip through the door closing panel as shown.

18.

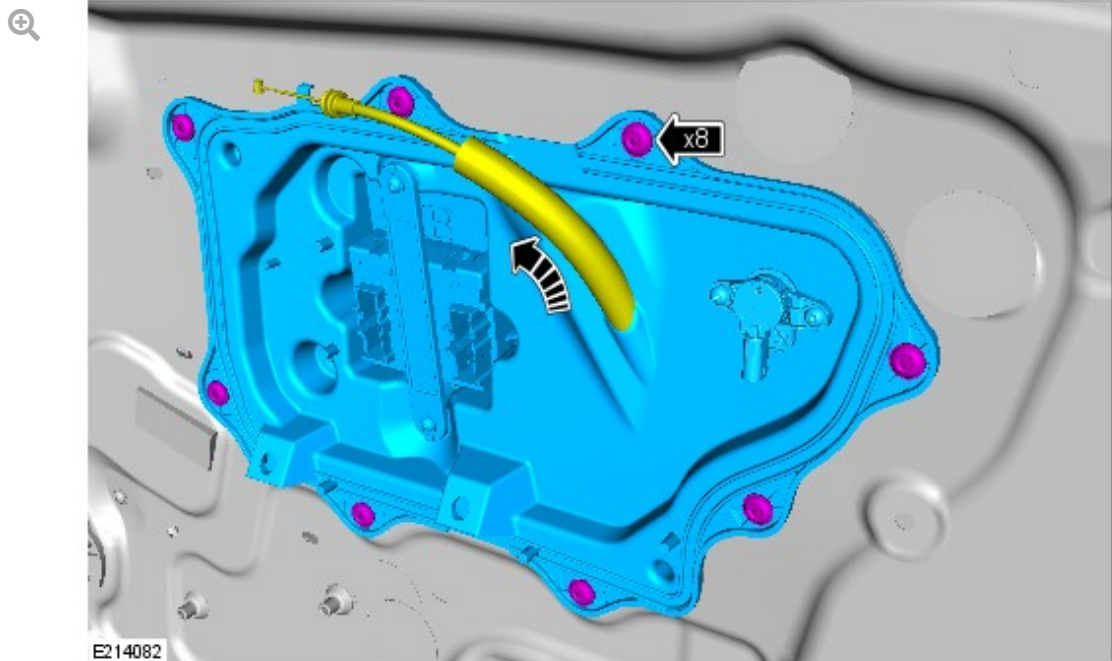

Install the front right door closing panel.

- ■ Torque: **2 Nm**.

19.

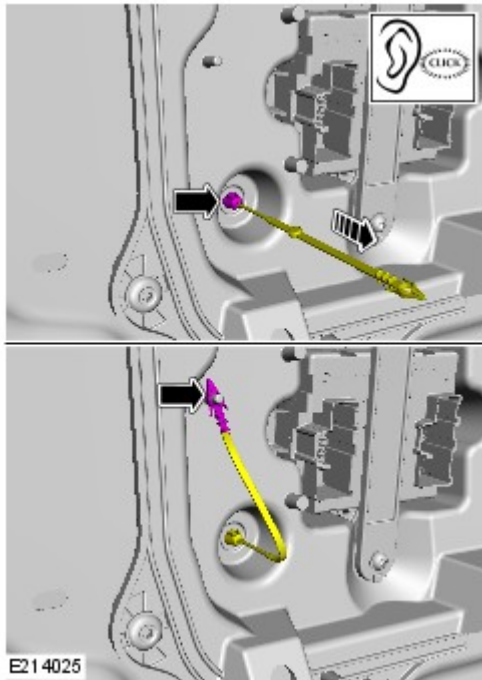

Install the door window regulator retaining clip.

20. To install, reverse the removal procedure.

SERVICE INSTRUCTION 'B' - FRONT LEFT DOOR

1. Perform Service Instruction 'A' with the following changes.
 - **1.** The connectors on the front left door electrical wiring harness are **C5PK09** and **C5PL63**.
 - **2.** Install the repair wire into cavity 5 of electrical connector **C5PK09**
 - **3.** Create a splice joint between the repair wire and the wiring in cavity 4 of **C5PL63** on the front left door electrical wiring harness.

SERVICE INSTRUCTION 'C' - REAR RIGHT DOOR

1. Perform Service Instruction 'A' with the following changes.
 - **1.** The connectors on the rear right door electrical wiring harness are **C8PK12** and **C8PL72**.
 - **2.** Install the repair wire into cavity 2 of electrical connector **C8PK12**.
 - **3.** Create a splice joint between the repair wire and the wiring in cavity 5 of **C8PL72** on the rear right door electrical wiring harness.

SERVICE INSTRUCTION 'D' - REAR LEFT DOOR

1. Perform Service Instruction 'A' with the following changes.
 - **1.** The connectors on the rear left door electrical wiring harness are **C7PK11** and **C7PL72**.
 - **2.** Install the repair wire into cavity 5 of electrical connector **C7PK11**.
 - **3.** Create a splice joint between the repair wire and the wiring in cavity 4 of **C7PL72** on the rear left door electrical wiring harness.