



SERVICE BULLETIN

December, 2020

Subject: **GPS Not Charging - Possible Inverted Wires at Vehicle Connector**

No.

2020-7

SERVICE INFORMATION

YEAR	MODEL
2018 and newer	Spyder F3 T and F3 Limited
2020 and newer	Spyder RT Series

Vehicles equipped with GPS kit may experience inner battery charging issues. One of the probable cause is inverted wires at vehicle connector

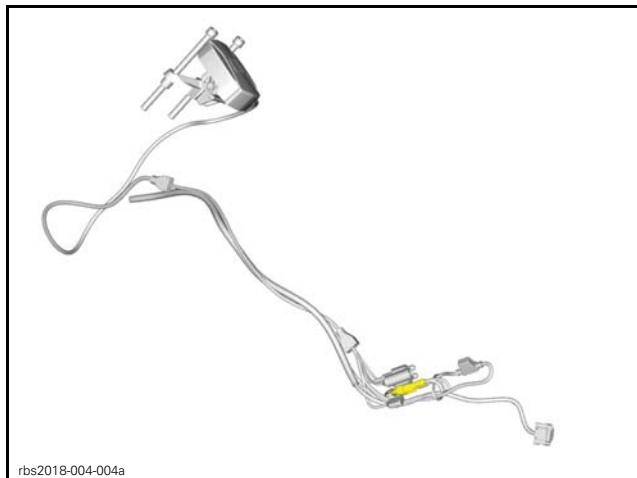

PROCEDURE

Refer to the following procedures.

1. Access the GPS connector

Spyder F3

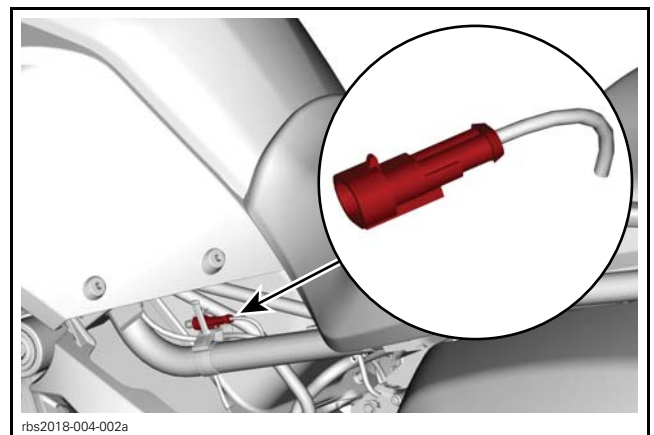
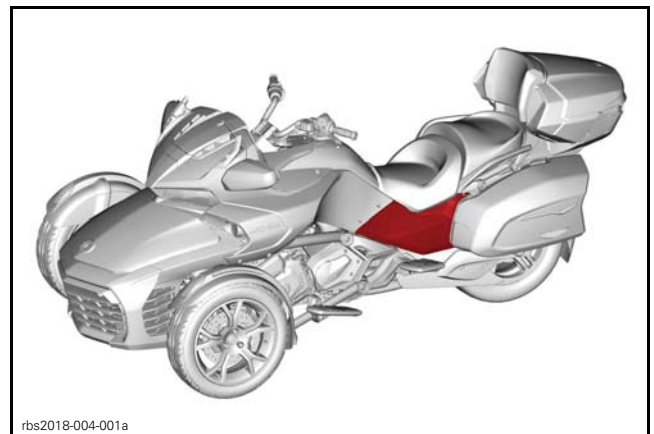

Spyder RT

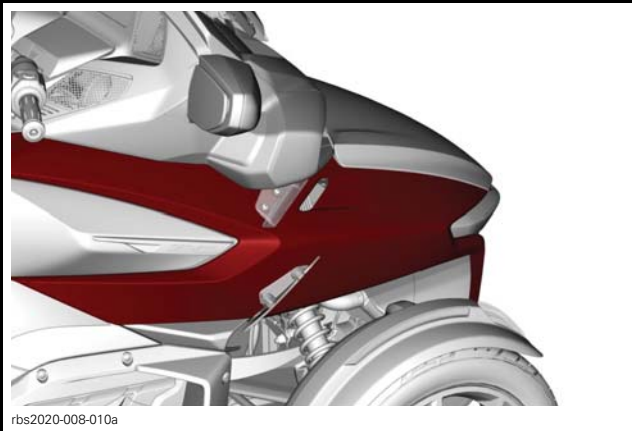

Always refer to the appropriate *ONLINE REPAIR MANUAL* for the latest informations and procedures.

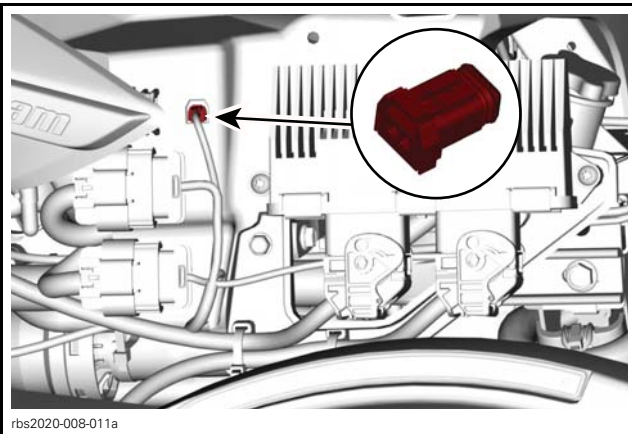

2. Make sure the black wire on the male connector is on the same side as the female connector.

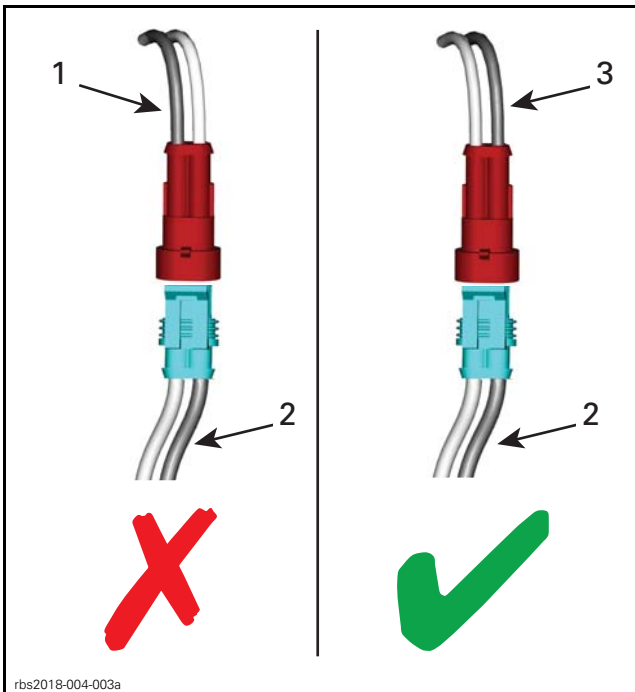

1. Black wire on female connector at the wrong location
2. Black wire on male connector
3. Black wire on female connector at the appropriate location