

FLA COE
FLB COE
FLD Conventional
Business Class
FLC 112 Conventional

Century Class Conventional
Argosy
Cargo
Columbia
> 122SD and Coronado

> Business Class M2
> Cascadia
> 108SD/114SD
New Cascadia

**Freightliner
Service Bulletin**

General Information

Specific Freightliner vehicles manufactured February 7, 2018 through December 23, 2020, with Detroit front axles and Meritor™ EX-L front air disc brakes do not have access to the front brake zerk fittings for lubrication.

The solution to this problem is to move the brake calipers 40 degrees rear of the center line. This is obtained by replacing the old anchor plates with the new design. See [Table 1](#) and [Table 2](#). As the brake calipers move to the new position, the existing brake chambers must be replaced to accommodate this change. See [Table 3](#), [Table 4](#) and [Table 5](#).

Parts

Anchor Plates

Old Anchor Plates			
BOM Number	BOM Description	Part Number	Part Description
402-C05101	BK ,MER,1B1,761,3/4,S,FL	ROK3215P2538	ANC PLT,1B1,000RH1975619X
		ROK3215Q2539	ANC PLT,1B1,000LH1975619X

Table 1, Old Anchor Plates

Replacement Anchor Plates			
BOM Number	BOM Description	Part Number	Part Description
402-C05105	BK ,MER,1B1,93X,FL40A,S	ROK3215T2776	ANC PLT,1B1,040RH1975619X
		ROK3215U2777	ANC PLT,1B1,040LH1975619X

Table 2, Replacement Anchor Plates

Brake Chambers

Old Brake Chambers			
BOM Number	BOM Description	Part Number	Part Description
404-C01317	CHMBR,2,BDX,S20,ADB22X-V	BW K153202	CHBR,BDX,ADB,S20,LH,0,270
		BW K133519	CHBR,BDX,ADB,S20,RH,0,90
404-T50007	CHMBR,2,BDX,S24,ADB22X-V	BW K097130	CHBR,BDX,ADB,S24,LH,0,90
		BW K097129	CHBR,BDX,ADB,S24,RH,0,270
404-C01309	CHMBR,2,BDX,S24,ADB22X-V	BW K097130	CHBR,BDX,ADB,S24,LH,0,90
		BW K097129	CHBR,BDX,ADB,S24,RH,0,270
404-C01316	CHMBR,2,BDX,S24,ADB22X-V	BW K153226	CHBR,BDX,ADB,S24,LH,0,90
		BW K133548	CHBR,BDX,ADB,S24,RH,0,270

Table 3, Old Brake Chambers

New Brake Chambers – Bendix (For Replacements Before January 18, 2021)			
BOM Number	BOM Description	Part Number	Part Description
404-C01804	CHMBR,2,BDX,S20,CAL-AFT	BW K151861	CHBR,BDX,ADB,S20,LH,045,315
		BW K151860	CHBR,BDX,ADB,S20,RH,135,225

Freightliner Service Bulletin

FLA COE
FLB COE
FLD Conventional
Business Class
FLC 112 Conventional

Century Class Conventional
Argosy
Cargo
Columbia
> 122SD and Coronado

> Business Class M2
> Cascadia
> 108SD/114SD
New Cascadia

New Brake Chambers – Bendix (For Replacements Before January 18, 2021)			
BOM Number	BOM Description	Part Number	Part Description
404-C01807	CHMBR,2,BDX,S24,CAL-AFT	BW K152687	CHBR,BDX,ADB,S24,LH,045,315
		BW K152686	CHBR,BDX,ADB,S24,RH,135,215

Table 4, New Brake Chambers – Bendix (For Replacements Before January 18, 2021)

New Brake Chambers – WABCO (For Replacements January 18, 2021 Onwards)			
BOM Number	BOM Description	Part Number	Part Description
404-C01812	CHMBR,2,WAB,S20,ADB,CAL-AFT	WAB423 505 065 0	CHBR,BDX,ADB,S20,LH,045,315
		WAB423 505 067 0	CHBR,BDX,ADB,S20,RH,135,225
404-C01815	CHMBR,2,WAB,S24,ADB,CAL-AFT	WAB423 506 153 0	CHBR,WAB,ADB,S24,LH,045,090
		WAB423 506 154 0	CHBR,WAB,ADB,S24,RH,135,090

Table 5, New Brake Chambers – WABCO (For Replacements January 18, 2021 Onwards)

Anchor Plate Replacement

This procedure is applicable to the front steer axle only. Refer to [Fig. 1](#) and [Fig. 2](#).

FLA COE
FLB COE
FLD Conventional
Business Class
FLC 112 Conventional

Century Class Conventional
Argosy
Cargo
Columbia
> 122SD and Coronado

> Business Class M2
> Cascadia
> 108SD/114SD
New Cascadia

**Freightliner
Service Bulletin**

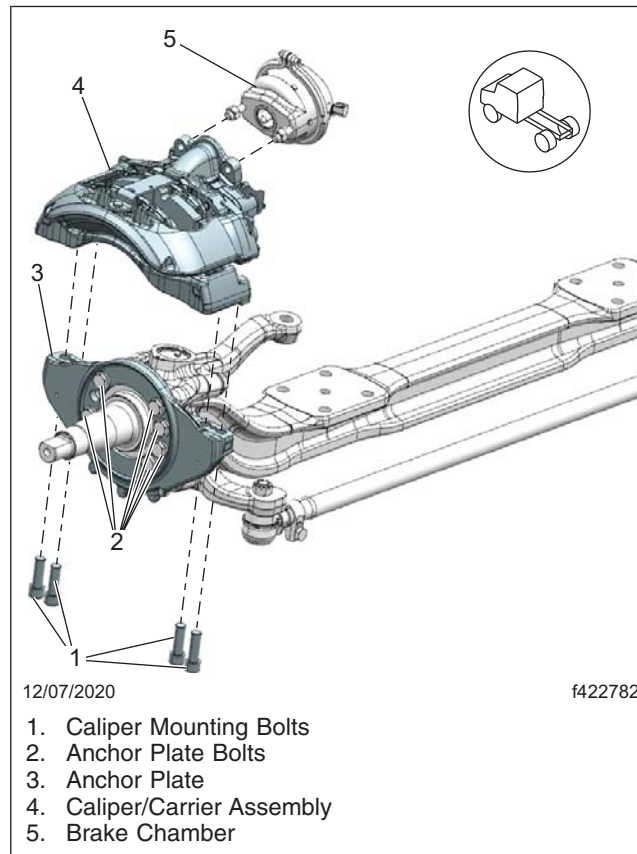

Fig. 1, Brake Calipers Mounted on Old Anchor Plates

Freightliner Service Bulletin

FLA COE
FLB COE
FLD Conventional
Business Class
FLC 112 Conventional

Century Class Conventional
Argosy
Cargo
Columbia
> 122SD and Coronado

> Business Class M2
> Cascadia
> 108SD/114SD
New Cascadia

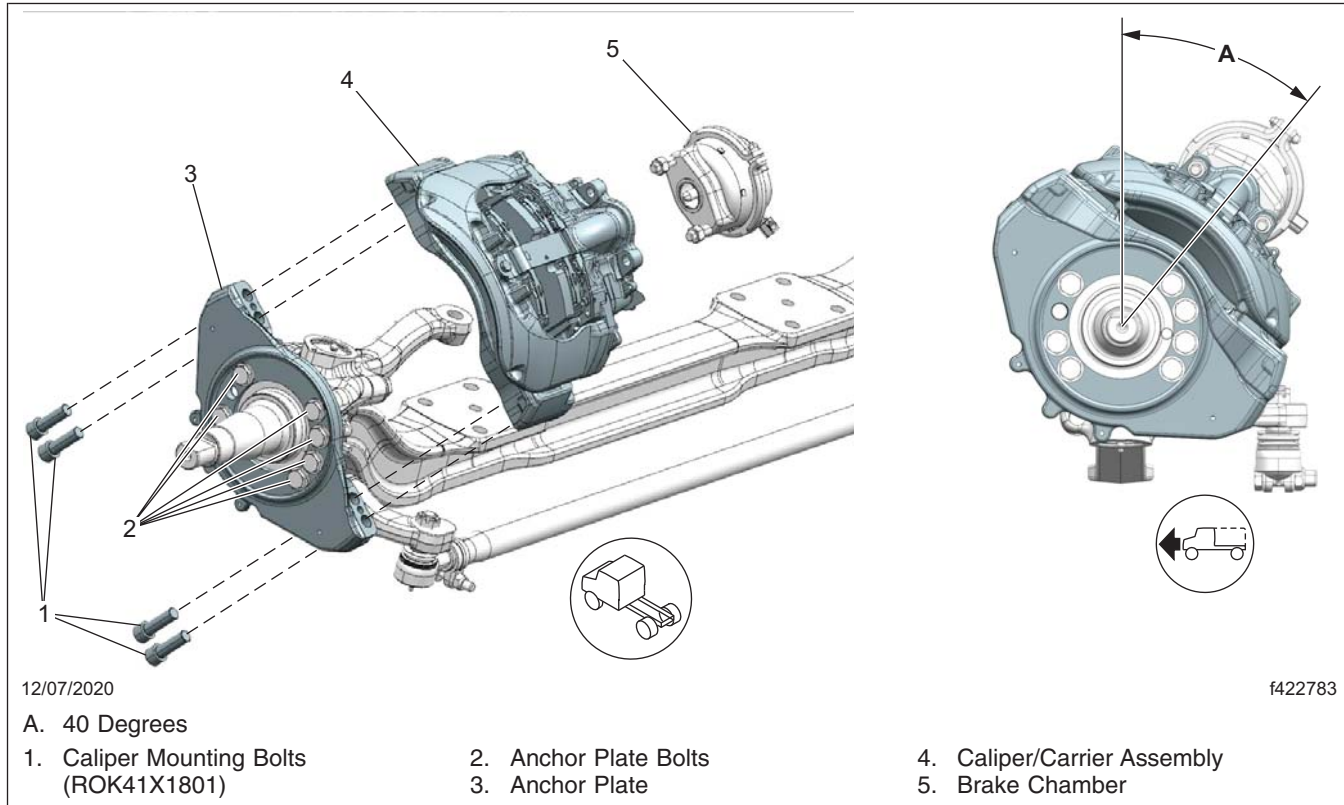

Fig. 2, Brake Calipers Mounted on New Anchor Plates

1. Park the vehicle on a level surface, shut down the engine, and set the parking brake. Chock the tires.

! DANGER

When working on the vehicle, shut down the engine, set the parking brake, and chock the tires. Before working under the vehicle, always place jack stands under the frame rails to ensure the vehicle cannot drop. Failure to follow these steps could result in serious personal injury or death.

2. Raise the vehicle and support it on jack stands.
3. Open the hood.
4. Remove the wheel assemblies. For instructions, refer to **Group 40** of the applicable workshop manual.
5. Drain all the air pressure from the air brake system.
6. Disconnect the left-hand (LH) and right-hand (RH) side air hoses at the frame rail connection.
7. Remove the brake chambers from the air disc brake calipers. For instructions, refer to **Group 42** of the applicable workshop manual.
8. Back off the automatic caliper adjuster.
9. Remove and discard the brake caliper bolts.
10. Remove the brake calipers from the vehicle.

FLA COE
 FLB COE
 FLD Conventional
 Business Class
 FLC 112 Conventional

Century Class Conventional
 Argosy
 Cargo
 Columbia
 > 122SD and Coronado

> Business Class M2
 > Cascadia
 > 108SD/114SD
 New Cascadia

11. Remove the wheel hubs. For instructions, refer to **Group 33** of the applicable workshop manual.
12. Remove the antilock braking system (ABS) sensors from the caliper mounting brackets. For instructions, refer to **Group 42** of the applicable workshop manual.
13. Remove the anchor plate fasteners, and remove the anchor plates from the spindle. Discard the anchor plates.
14. Install new anchor plates on the spindle. See **Table 2**. Torque to 199 lbf-ft (270 N·m).
15. Install the wheel hubs. For instructions, refer to **Group 33** of the applicable workshop manual.
16. Install the ABS sensors onto the caliper mounting brackets. For instructions, refer to **Group 42** of the applicable workshop manual.

IMPORTANT: The caliper/carrier assemblies are left and right handed. Ensure that the correct assembly (left or right) is installed on each side of the vehicle.

17. Align each caliper/carrier assembly with the rotor by pushing the fixed pin side of the caliper against the shelf on the torque plate, then install the caliper/carrier assembly using new caliper mounting bolts as follows. See **Fig. 2**.

Tighten the carrier mounting bolts in two steps, using the pattern shown in **Fig. 3**.

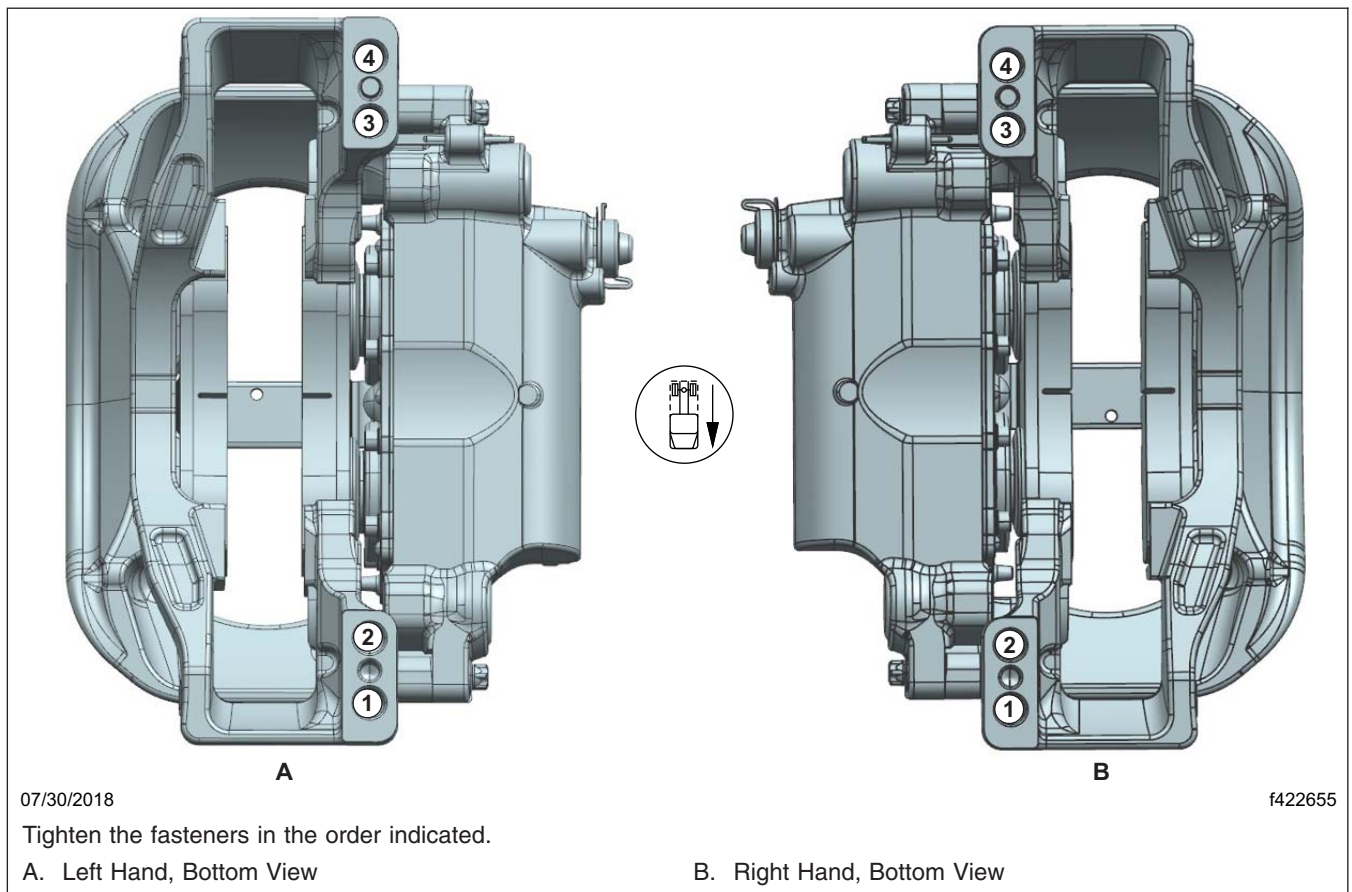

Fig. 3, Tightening Pattern, Meritor Caliper

**Freightliner
Service Bulletin**

 FLA COE
 FLB COE
 FLD Conventional
 Business Class
 FLC 112 Conventional

 Century Class Conventional
 Argosy
 Cargo
 Columbia
 > 122SD and Coronado

 > Business Class M2
 > Cascadia
 > 108SD/114SD
 New Cascadia

NOTE: The tightening pattern will always start on the short (floating) pin side, with the bolt that passes through the sheer sleeve.

- 17.1 Initially tighten all bolts 45 ± 5 lbf·ft (61 ± 7 N·m). Slide the caliper inboard and outboard, through the center of the chamber or brake. The caliper must have a minimum of 20 mm of travel. If the brake assembly does not move, or requires more than 40 pounds of force to move, the caliper has a binding issue. Repeat the torque pattern, if that does not resolve the binding issue, replace the caliper.
- 17.2 Apply final torque to the bolts 400 ± 50 lbf·ft (542 ± 68 N·m). Slide the caliper inboard and outboard, through the center of the chamber or brake. The caliper must have a minimum of 20 mm of travel. If the brake assembly does not move, or requires more than 40 pounds of force to move, the caliper has a binding issue. Repeat the torque pattern, if that does not resolve the binding issue, replace the caliper.

NOTICE

Do not use a motor driven tool to tighten the manual brake adjuster nut, or use excessive force to tighten the nut. Doing so could damage the manual brake adjuster nut.

18. Tighten the caliper adjuster until it stops, then back off the adjuster nut three clicks.
19. Install new the brake chambers. See [Table 4](#) and [Table 5](#). For instructions, refer to **Group 42** of the applicable workshop manual.
20. Install the LH and RH side air hoses from the old brake chamber, then connect the hoses to the frame rail connectors.
21. Install the wheels assemblies. For instructions, refer to **Group 40** of the applicable workshop manual.
22. Raise the vehicle, remove the jack stands, then lower the vehicle.
23. Charge the air system and check for leaks.

 **WARNING**

Do not operate the vehicle until the brakes have been adjusted and checked for proper operation. To do so could result in inadequate or no braking ability, which could cause personal injury or death, and property damage.

24. In a safe area, check for proper brake operation, as follows, before putting the vehicle in service.
- 24.1 Apply and release the brakes several times to check for air leaks and proper operation.
- 24.2 Perform six low-speed stops to ensure proper parts replacement and full vehicle control.
- 24.3 Immediately after doing the above stops, check the rotor temperatures. Any rotors that are significantly cooler than others indicate a lack of braking effort on those wheels.

Warranty

This is an information bulletin only and not intended for pro-active work. Warranty does not apply.