



SIB 52 09 20

2020-11-02

## HEAD RESTRAINT AND/OR BACKREST OF 3RD ROW SEATS CANNOT BE FOLDED DOWN

### MODEL

E-Series	Model Description
G07	X7 Sports Activity Vehicle

### SITUATION

Various concerns about the third row of seats:

1. Head restraint (aka headrest), on one or both sides, cannot be folded down.
2. Third-row seating, on one or both sides, cannot be folded down.

### CAUSE

1. Head restraint (aka headrest), on one or both sides, cannot be folded down:
  - Head restraint mechanism is faulty
  - Bowden cable is not routed correctly, or not mounted
  - Bowden cable mechanism (when cable is under tension it is too short)
2. Third-row seating, on one or both sides, cannot be folded down:
  - Drivetrain for backrest release (actuator) is faulty
  - Drivetrain for backrest tilt adjustment is faulty
  - Bowden cable not correctly mounted.

### CORRECTION

Depending on the problem found, one or more of the following corrections will be required:

1. Replace the head restraint mechanism
2. Replace the Bowden cable
3. Re-route the Bowden cable
4. Replace the drivetrain for backrest release (actuator)
5. Replace the drivetrain for backrest tilt adjustment

### PROCEDURE

For an overview of seat operation please refer to [TRI 52 23 19](#)

Program the vehicle with ISTA to the most recent I-level.

**NOTE:** Software improvements were released August 2019 which changed certain seat operations on early production vehicles. For a detailed list of the changes see SI [B52 21 19](#).

Then proceed as follows:

1. Head restraint cannot be folded down:

Can the head restraint be manually unlocked using the release loop beneath the headrest (see picture) and thus folded down?

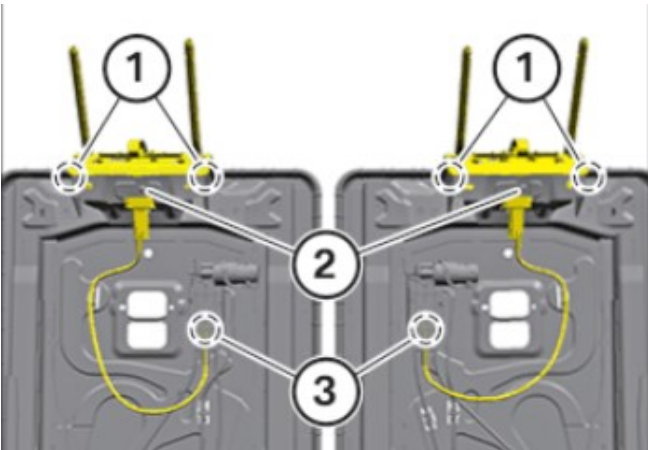

**YES** = Head restraint mechanism is faulty.  
Replace the folding module of the head restraint (#2 in picture).

See REP 52 30 118 Remove and install/replace folding module of left or right head restraint

**NOTE:** The head restraint cannot be removed without destroying the covering material. **A new cover (leather) will be required to perform this repair.**

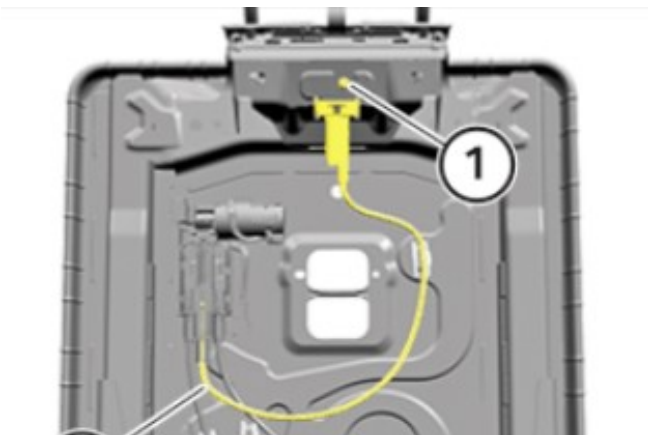

**NO** = Check if the Bowden cable is correctly mounted and properly routed.

If the Bowden cable is mounted and correctly routed, replace the Bowden cable for the headrest (shown in yellow in picture).

See REP 52 30 253 Replace Bowden cable for left or right head restraint (Bowden cable unlocking device for head restraint).

2. Third-row seating cannot be folded down:

Check if the latch (the fastener on the left or right side) of the third row of seats is open or closed? (this is the hook/pin shown in green in picture)

As a quick check for this, proceed as follows:

Fold the rear seat backrest of the third row of seats including the head restraint into seating

G07 3<sup>rd</sup> Row Seat – Overview Picture.

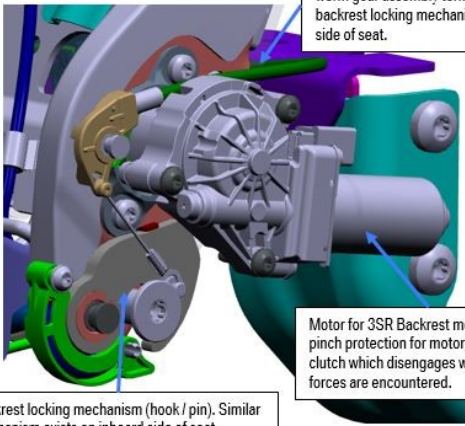

Bowden cable which originates at motor / worm gear assembly terminating at backrest locking mechanism on outboard side of seat.

Motor for 3SR Backrest movement. No pinch protection for motor, but has clutch which disengages when high forces are encountered.

Backrest locking mechanism (hook / pin). Similar mechanism exists on inboard side of seat.

position.

If the head restraint stays in the seat position, the latch is closed.

If the head restraint falls into the folded position again, the latch is open.

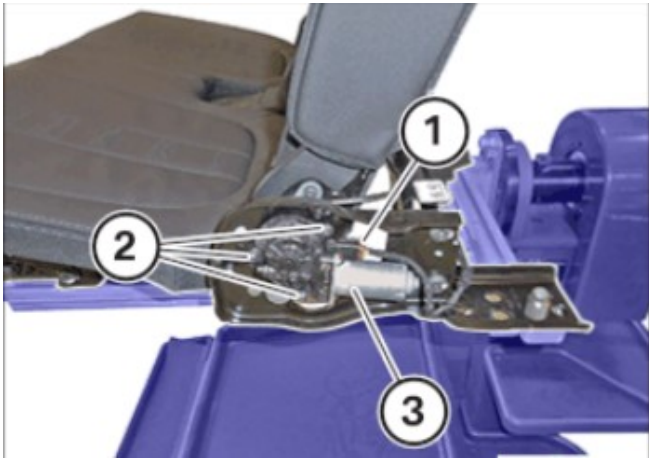

**YES** (Latch is open) = Replace drivetrain of backrest tilt adjustment.

See REP 67 31 635 Remove and install/replace drivetrain for backrest tilt adjustment of third-row seating (left or right) (according to vehicle diagnosis)

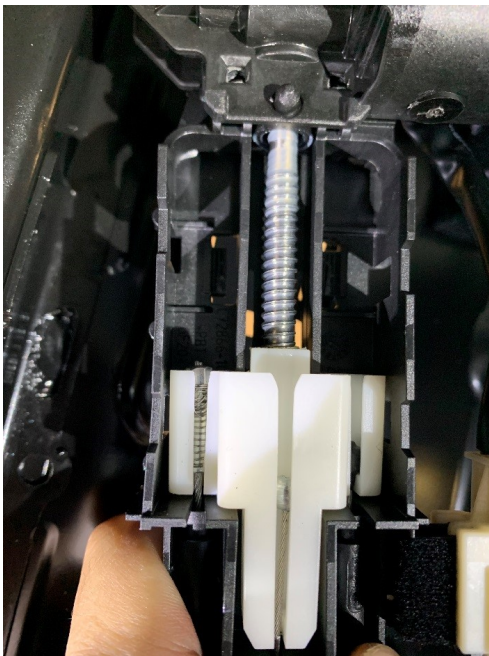

**NO** (Latch is closed) = Check if the drivetrain for backrest release adjustment is broken?

**NOTE:** The 3 Bowden cables are housed in a common housing that moves along a worm gear assembly.

When the electric motor activates, it spins the worm gear to pull up on the housing so that all 3 cables move simultaneously

One of the cables controls the head restraint folding. Once pulled, the headrest will release and pivot downwards. **Raising the headrest back into the upright position must be done by pushing up on it by hand.**

(The other two cables control the latch release at the seat pivot to enable the seat to fold.)

For more details see either video:

- [B52 01 19](#) - G05/G07 Seat Troubleshooting 6 Passenger

- [B52 02 19](#) - G05/G07 Seat Troubleshooting 7 Passenger

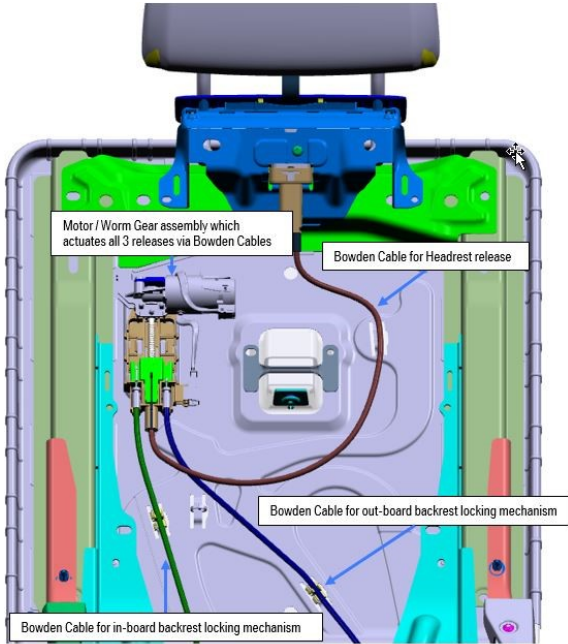

Is the drivetrain for the backrest release (actuator) broken?

**YES** = Replace only the drivetrain for backrest release (actuator).

See REP 67 31 645 Remove and install/replace drivetrain for backrest release of third-row seating (left or right) (according to vehicle diagnosis)

**NO** = Replace BOTH the Bowden cable(s) and drivetrain for backrest release (actuator).

See appropriate repair instruction:  
 REP 52 30 256 Replace Bowden cable for left or right rear seat backrest (Bowden cable for outer backrest release)

REP 52 30 255 Replace Bowden cable for left or right rear seat backrest (Bowden cable for inner backrest release)

REP 67 31 645 Remove and install/replace drivetrain for backrest release of third-row seating (left or right) (according to vehicle diagnosis)

Then re-evaluate the vehicle.

## PARTS INFORMATION

Obtain and confirm the part numbers for your specific vehicle by entering the chassis number in either ETK or AIR which takes into account specific equipment and/or options.

This is an overview list of parts required to make these repairs. You will only need one or more of these parts to repair your vehicle.

Part Number	Description	Quantity
52 30 7 485 444	Bowden Cable Unlocking	2
52 20 9 473 697	Actuator backrest folding	1
52 20 9 473 695	Drive backrest folding left	1
52 20 9 473 696	Drive backrest folding right	1
52 30 5 A1E 228	Bowden cable actuator left	1
52 30 5 A1E 229	Bowden cable actuator right	1
52 30 7 941 595	Headrest leather rear (schwarz)	2
52 30 9 496 669	Folding module head rest	1



## **WARRANTY INFORMATION**

This service information bulletin provides technical, diagnostic and/or repair-related information.

### **Eligible and Covered Work/Repairs**

When used to repair a verified defect in materials or workmanship, the applicable repair procedure information that is provided in this bulletin is covered under the terms of the BMW New Vehicle Limited Warranty for Passenger Cars and Light Trucks.

To submit a claim, please following the established and applicable warranty policy and procedures (Labor/Part/Sublet – bulk materials/qualifying third-party repairs) that apply to the repair being performed.

Refer to AIR for the corresponding defect code, flat rate labor operations (including diagnosis) and the flat rate unit (FRU) allowances.

Only one Main labor operation code can be claimed per repair visit.

As applicable to your center, please refer to [SI B01 01 20](#) or [B01 07 20](#) for claiming your diagnosis work time, job/repair work time (WT), WT and the repair-related explanation procedures.

## **QUESTIONS REGARDING THIS BULLETIN**

Technical inquiries	Submit feedback at the top of this bulletin
Warranty inquiries	Submit an IDS ticket to the Warranty Department or use the chat available in the Warranty Documentation Portal
Parts inquiries	Submit an IDS ticket to the Parts Department