

SERVICE ACTION

Reference number:	SA-63-1452	Issued: 06 November, 2020
Subject:	EPAS Harness Inspection and Repair	
Model(s):	DBX	
VIN Range:	Refer to the separately published list of affected Vehicle Identification Numbers (VINs)	
Applicable to:	All Dealers	
Distribute to:	After Sales Manager Executive Manager Service Manager Sales Manager	Warranty Staff Technician(s) Parts Staff

Reason for this Service Action

Aston Martin has found damage to the Electronic Power Assisted Steering (EPAS) harness on some DBX vehicles. Do the workshop procedures that follow to examine and if necessary repair the EPAS harness.

Workshop Procedure

This workshop procedure has three parts:

- Part A: Remove and Examine the EPAS Harness
- Part B: Repair the EPAS Harness
- Part C: Re-install the EPAS Harness to the Fuse Box

Part A: Remove and Examine the EPAS Harness

1. Disconnect the battery (refer to Workshop Manual Procedure 63.01.AK).
2. Remove the left side access panel for the leaf screen (refer to Workshop Procedure 31.10.CB).
3. Remove the two screws that attach the cover to the fuse box (refer to Figure 1).

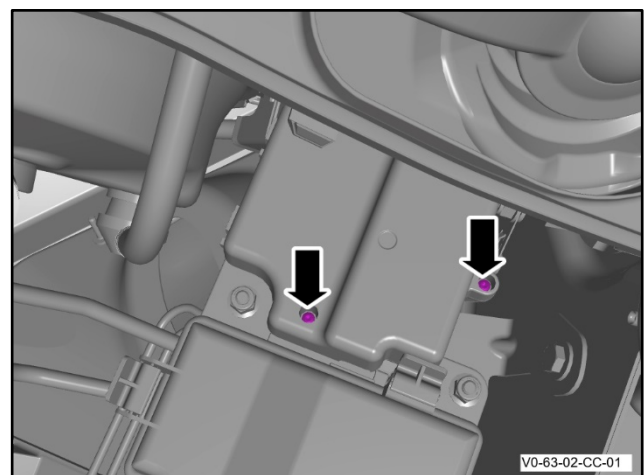

Figure 1

4. Remove the cover for the fuse box (refer to Figure 2).

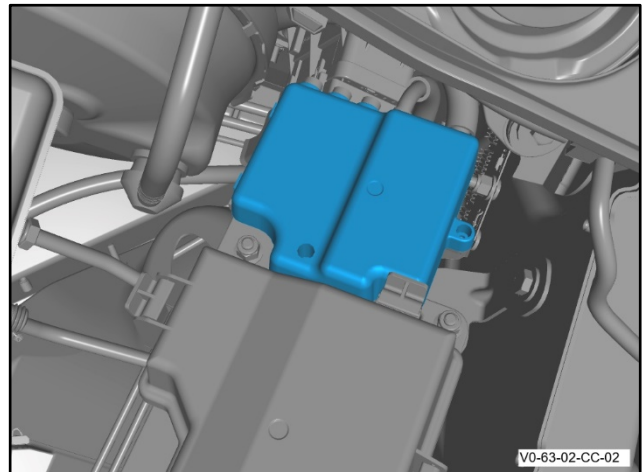

Figure 2

5. Remove the nut that attaches the cable to the fuse box (refer to Figure 3).

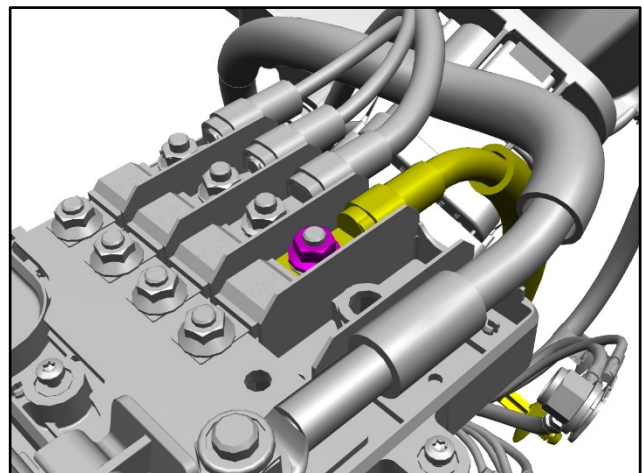

Figure 3

6. Use an applicable tool to remove the tape for the EPAS cable (refer to Figure 4).

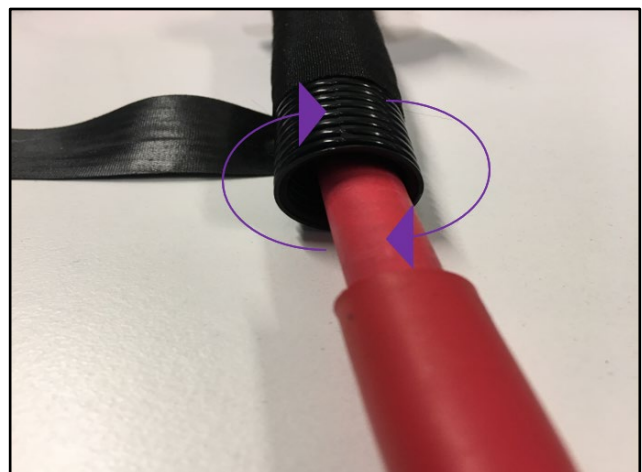

Figure 4

7. Examine the EPAS harness for damage.

This image shows an EPAS cable where a repair is not necessary (refer to Figure 5).

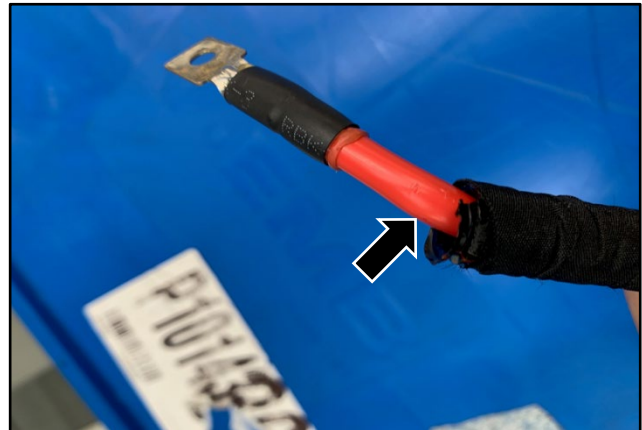

Figure 5

This image shows an EPAS cable where a repair is necessary (refer to Figure 6).

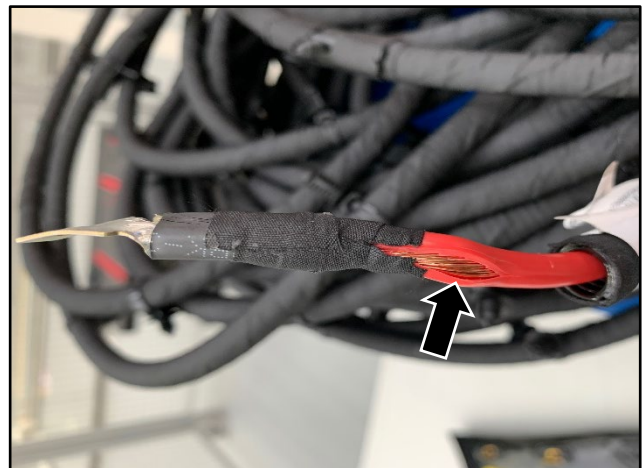

Figure 6

Note: If repair is not necessary on the EPAS cable, do Part C: Re-install the EPAS Harness to the Fuse Box.

Part B: Repair the EPAS Harness

1. Install adhesive heat-shrink to cover and seal the damaged cable (refer to Figure 7).

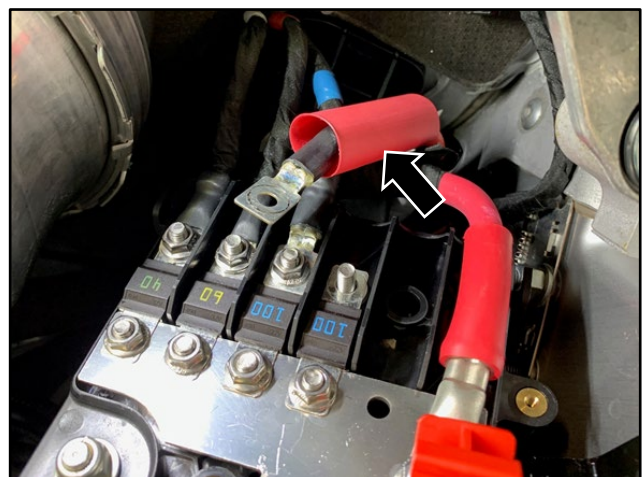

Figure 7

2. Use a heat gun to apply heat to the heat-shrink until the shrink forms a seal around the cable (refer to Figure 8).

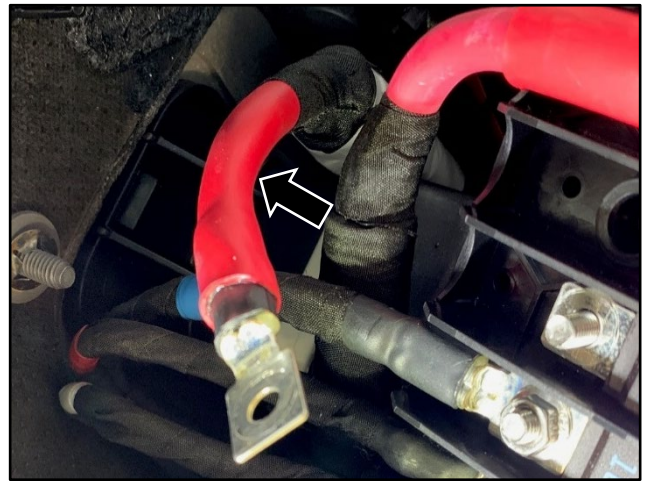

Figure 8

3. Apply protective tape to the cable (refer to Figure 9).



Figure 9

Part C: Re-install the EPAS Harness to the Fuse Box

1. Install and torque the nut that attaches the cable to the fuse box to 5 Nm (refer to Figure 10).

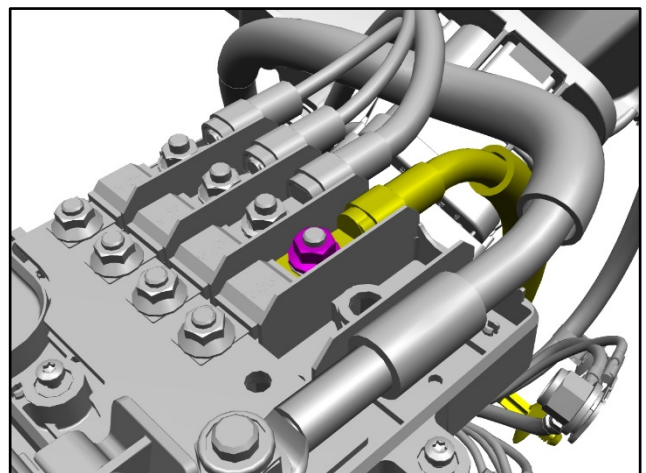

Figure 10

2. Install the cover for the fuse box (refer to Figure 11).

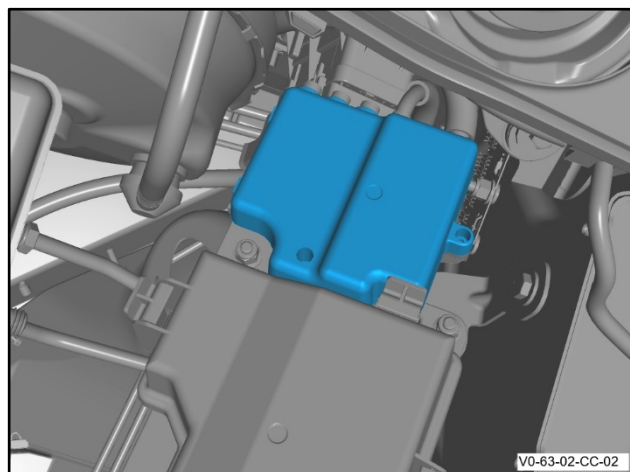

Figure 11

3. Install the two screws that attach the cover to the fuse box (refer Figure 12).

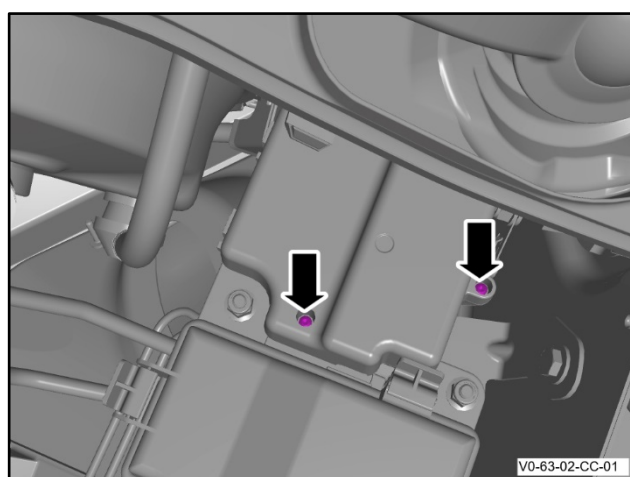

Figure 12

4. Install the left side access panel for the leaf screen (refer to Workshop Procedure 31.10.CB).
5. Connect the battery (refer to Workshop Manual Procedure 63.01.AK).

Warranty Data

Procedure and Labour Time

Description	Labour Time
Tier A: Part A + Part C	0.45h
Tier B: Part A + Part B + Part C	0.5h

If you have any questions related to this document, please refer to the 'Contact Us' link on this webpage, or contact your local Dealer or After Sales Manager.

The English version of this document is written in Simplified Technical English to ASD-STE100™.