

11/4/2020
CAL FTL 54-013

Subject: Updating the RP170 Customer Access Connector and Adding Overlays for J1939

Models Affected: Freightliner M2 106, M2 113, 108SD, and 114SD vehicles with datacode 33U-012 built before November 10, 2020.

Our records indicate that you are the owner of certain vehicles, and therefore DTNA has decided to share the following documentation with you.

Please see the attached communication in this email. We hope you find this information helpful.

11/4/2020
CAL FTL 54-013

Work Instructions

Subject: Updating the RP170 Customer Access Connector and Adding Overlays for J1939

Models Affected: Freightliner M2 106, M2 113, 108SD, and 114SD vehicles with data code 33U-012 built before November 10, 2020.

Work Instructions on Updating the RP170 Customer Access Connector¹

General Information

The Electrical Guide for M2106, M2112, 108SD, 114SD Body Builder Reference Guide Revision: D June 2019 incorrectly displays pins 2 and 3 of the customer access 8 pin connector on table 5 as “Hot with crank, Ignition controlled battery (+) thru Disconnect switch (If disconnect switch specified).” See [Fig. 1](#).

| TABLE 5: PIN ASSIGNMENT AND CIRCUIT DEFINITION 8-CONTACT CONNECTOR (POWER AND GROUND) | | | | | |
|--|---------|--------|------------|------------|---|
| Cavity | Source | Type | Amp Rating | Wire Gauge | Details |
| 1 | Chassis | Power | 20 | 12 | Battery (+) thru Disconnect switch (If disconnect switch specified) |
| 2 | Chassis | Power | 20 | 12 | Hot with crank, Ignition controlled battery (+) thru Disconnect switch (If disconnect switch specified) |
| 3 | Chassis | Power | 20 | 12 | Hot with crank, Ignition controlled battery (+) thru Disconnect switch (If disconnect switch specified) |
| 4 | Chassis | Power | 15 | 14 | Battery (+) Constant Hot |
| 5 | Chassis | Power | 25 | 12 | Ignition controlled Battery (+) Controlled through Reverse circuit |
| 6 | Chassis | Ground | 25 | 12 | Ground (-) Battery Direct |
| 7 | Chassis | Ground | 25 | 12 | Ground (-) Battery Direct |
| 8 | Chassis | Ground | 25 | 12 | Ground (-) Battery Direct |
| Chassis Side Connector: HDP24-18-8SN --Variation for seals (N,E) Body Builder Connector: HDP26-18-8PN --Variation for seals (N,E) | | | | | |

11/03/2020

f547378

Fig. 1, Pin Assignment and Circuit Definition 9-Contact Connector (Power and Ground)

Vehicles built with data code 33U-012 prior to November 10, 2020 will *not* have live power on pins 2 and 3 of the 8 pin connector while the key is in the crank position.

To correct for this error, 12 volts of constant battery power from the Powertrain Power Distribution Module (PTPDM) 70 amp ignition relay will replace the ignition supplied power from splice pack 12 (SP12A) in the dash harness.

Schematics referenced for these work instructions include G66-07101-001, G66-09354-001, and harness print A06-71941-000. BOM content is located in 33U, 283, and 320. Related installation prints are available in BOM content.

¹ Content for the RP170 customer access connector is located in module 33U of Parts Pro.

11/4/2020
CAL FTL 54-013

- Note that pins B and C of the 8 pin connector (See Fig. 2 from schematic G66-07101-001) are supplied with circuit 52F. Also note that pins B and C of the schematic are the same as pins 2 and 3 of the 8 pin connector noted in Fig. 1. These two locations will be updated to include constant uninterrupted 12 volt during cranking.

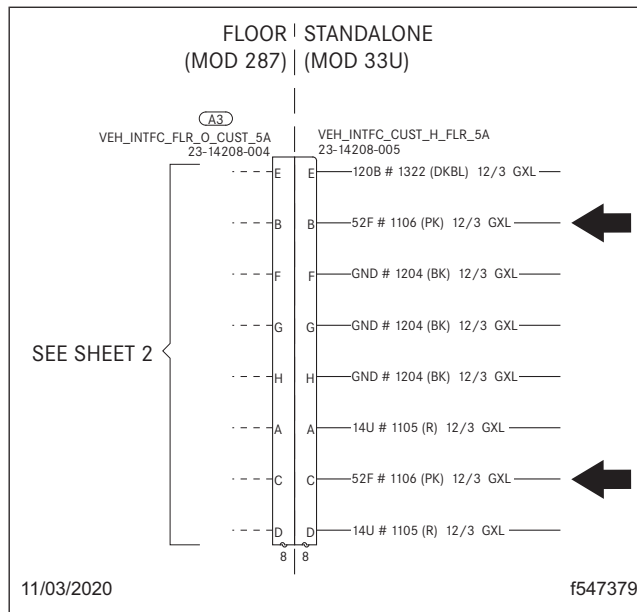

Fig. 2, Location of Pins B and C

- Note that circuit 14C originates from the main dash harness A06-71941-001 SP12A and routes to the 14 pin connector DASH_H_FLR_1A. See Fig. 3 from schematic G66-07101-001.

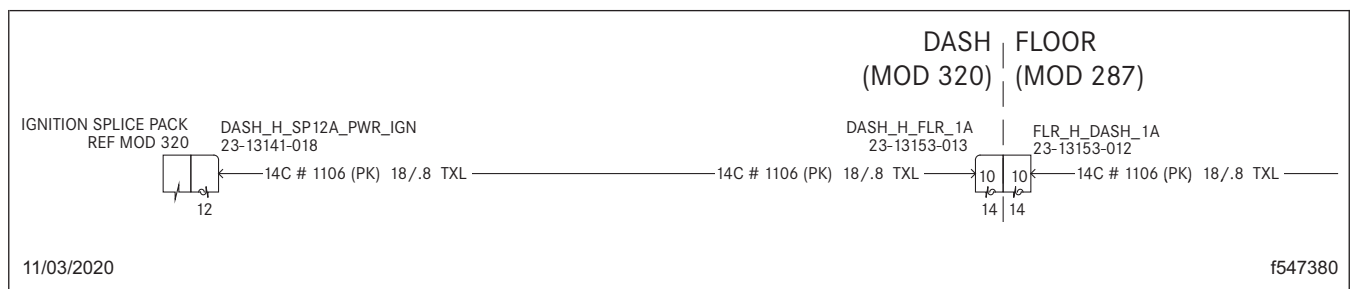

Fig. 3, SP12A Circuit 14C to 14 Pin Connector

- Note SP12A location. See Fig. 4 showing main cab dash harness A06-71941-001.

11/4/2020
CAL FTL 54-013

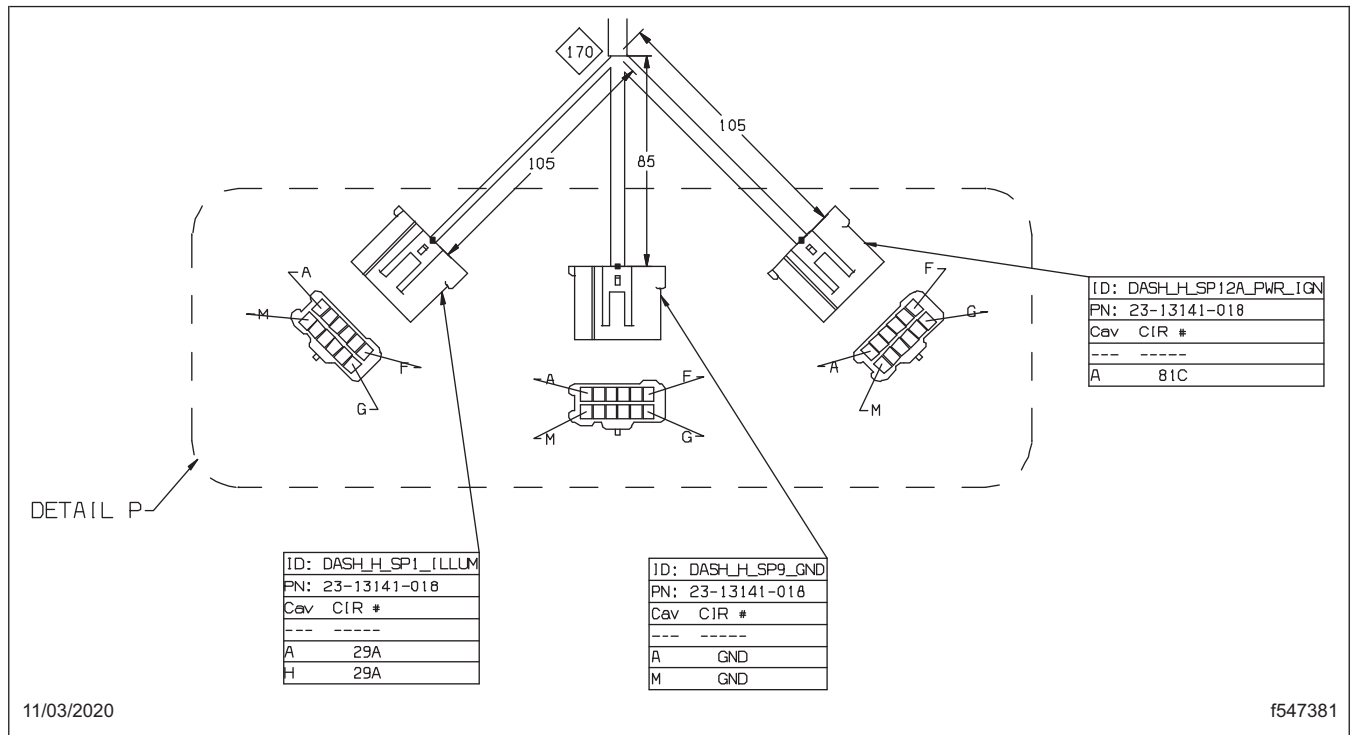

Fig. 4, Main Cab Dash Harness A06-71941-001, SP12A

- Remove circuit 14C from SP12A and then remove the DASH_H_FLR_1A connector from cavity 10. See [Fig. 5](#).

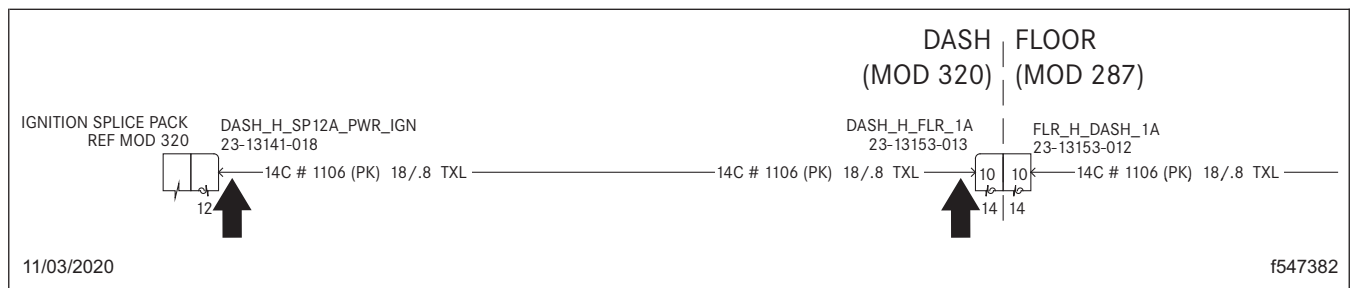

Fig. 5, Remove Circuit 14C from SP12A and the DASH_H_FLR_1A Connector

- Add one end of the circuit 14C overlay into PTPDM fuse 4. See [Fig. 6](#).

11/4/2020
CAL FTL 54-013

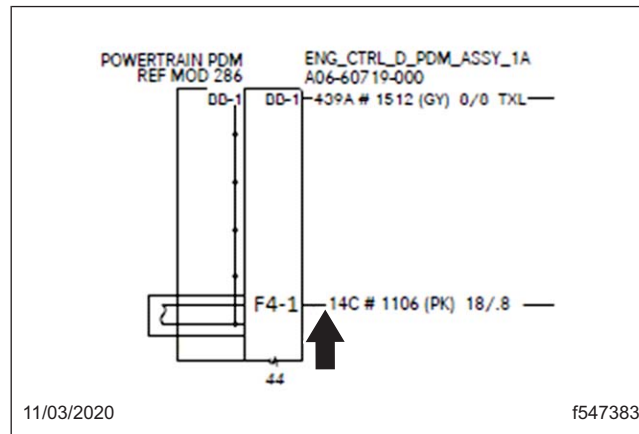

Fig. 6, Add 14C Overlay to Fuse 4 of the PTPDM

6. Add the opposite end of the 14C overlay back into the DASH_H_FLR_1A connector cavity 10. See [Fig. 7](#).

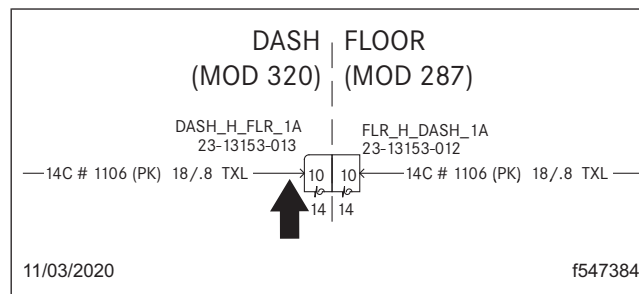

Fig. 7, Add Circuit 14C Overlay Back Into the DASH_H_FLR_1A Connector

7. See [Fig. 8](#) for a view of the completed modification. Note that circuit 14C now originates from the PTPDM fuse 4 to supply constant 12 volts during cranking.

11/4/2020
CAL FTL 54-013

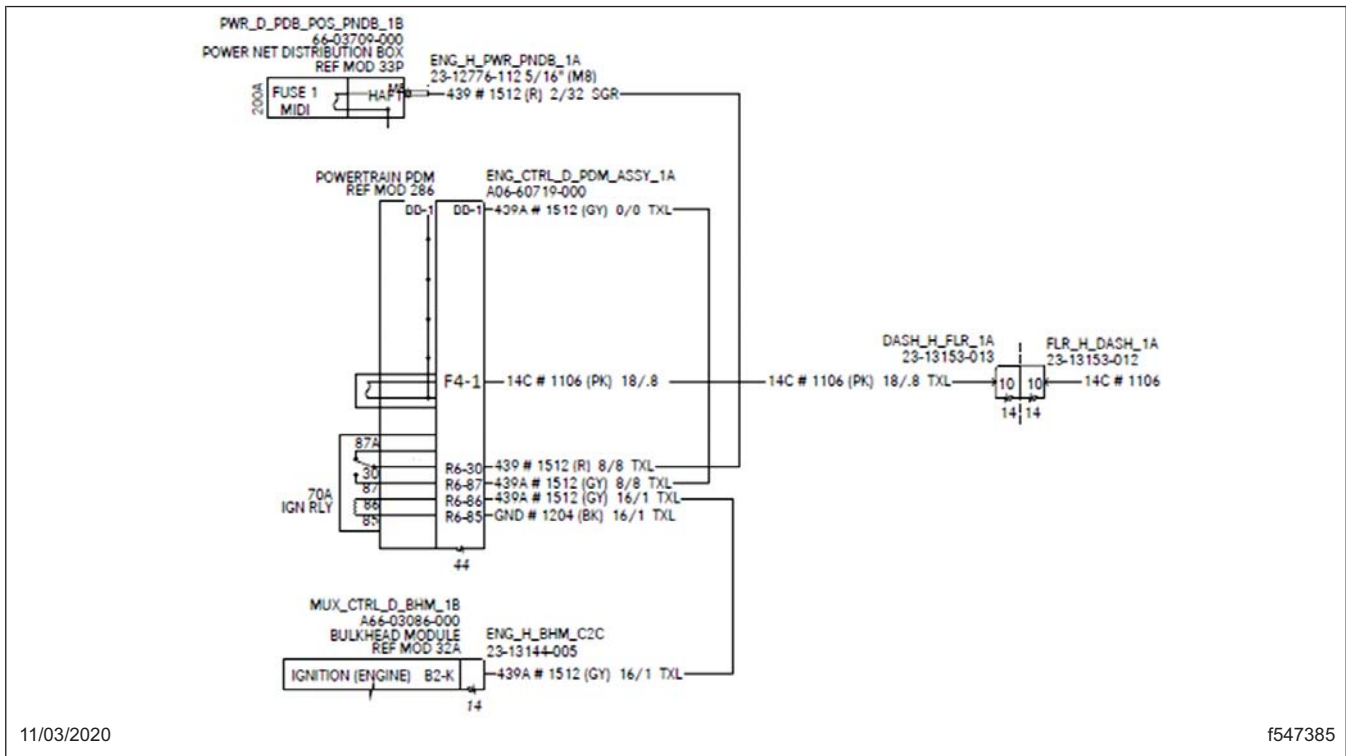

Fig. 8, Completed Modification of Circuit 14C Overlay

Work Instructions for Adding Overlays for J1939

General Information

The *Electrical Guide for M2106, M2112, 108SD, 114SD Body Builder Reference Guide Revision: D June 2019* incorrectly displays pins 5 and 6 of the customer access 31 pin connector as supplying variations of J1939 availability in tables 4 and 7. See [Fig. 9](#) and [Fig. 10](#). Vehicles built with data code 33U-012 prior to 11/10/20 will not have J1939 availability in either a 250K or 500K baud rate on pins 5 and 6 of the 31 pin connector.

11/4/2020
CAL FTL 54-013

| TABLE 4: PIN ASSIGNMENT AND POWER DEFINITION FOR 31-CONTACT CONNECTOR (POWERTRAIN) | | | | | | | |
|---|--------------------|--------------|-----------|--------------------------------|-----------------|------------|---|
| Cavity | Name | Source | Type | Function | Capacity (amps) | Wire Gauge | Details |
| 1 | Tachometer | engine | signal | R Terminal of Alternator | 0.1 | 18 | per TMC RP123A |
| 2 | ABS Response | ABS | signal | Retarder Disable | 1 | 18 | Ground signal activated to trigger a retarder disable relay |
| 3 | Throttle Limit | engine | signal | input | 0.1 | 18 | See Table 7 |
| 4 | Throttle Advance | engine | signal | input | 0.1 | 18 | See Table 7 |
| 5 | J1939 | engine | signal | communication | 0.1 | 18 | See Table 7, CAN H |
| 6 | J1939 | engine | signal | communication | 0.1 | 18 | See Table 7, CAN L |
| 7 | Throttle Interlock | engine | signal | input | 0.1 | 18 | See Table 7 |
| 8 | Road Speed limit | engine | signal | input | 0.1 | 18 | See Table 7 |
| 9 | Input Reference | engine | reference | electronic reference | 1 | 18 | See Table 7, ECU reference |
| 10 | Input 3 | engine | signal | reserved input | 0.1 | 18 | See Table 7 |
| 11 | Input 4 | engine | signal | reserved input | 0.1 | 18 | See Table 7 |
| 12 | Input 5 | engine | signal | reserved input | 0.1 | 18 | See Table 7 |
| 13 | Input 6 | vehicle | signal | Park Brake Applied | 0.1 | 18 | Ground signal activated when parking brake is applied |
| 14 | spare | spare | spare | spare | 0.1 | 18 | spare |
| 15 | input reference | transmission | reference | electronic +12V reference | 1 | 18 | See Table 8, TCU +12V reference, Allison 163 |
| 16 | Speedometer | transmission | signal | Speedometer pulse | 0.1 | 18 | See Table 8, per TMC RP123A, Allison 125 |
| 17 | TCU Common | transmission | ground | electronic ground reference | 1 | 18 | See Table 8, TCU ground reference, Allison 103 |
| 18 | Prog. Input 1 | transmission | signal | reserved input | 0.1 | 18 | See Table 8, Allison 123 |
| 19 | Prog. Input 3 | transmission | signal | EOS enable typ. | 0.1 | 18 | See Table 8, Allison 143 |
| 20 | Prog. Input 4 | transmission | signal | reserved input | 0.1 | 18 | See Table 8, Allison 122 |
| 21 | Prog. Input 5 | transmission | signal | Auto Neutral typ. | 0.1 | 18 | See Table 8, Allison 142 |
| 22 | Prog. Input 6 | transmission | signal | Shift Selector Transition typ. | 0.1 | 18 | See Table 8, Allison 101 |
| 23 | Prog. Input 9 | transmission | signal | reserved input | 0.1 | 18 | See Table 8, Allison 162 |
| 24 | Prog. Input 10 | transmission | signal | Auto Neutral typ. | 0.1 | 18 | See Table 8, Allison 117 |
| 25 | Prog. Output 1 | transmission | signal | EOS signal typ. | 0.5 | 18 | See Table 8, Allison 130 |
| 26 | Prog. Output 3 | transmission | signal | Neutral indicator typ. | 0.5 | 18 | See Table 8, Allison 145 |
| 27 | Prog. Output 4 | transmission | signal | Output Speed Indicator typ. | 0.5 | 18 | See Table 8, Allison 105 |
| 28 | Prog. Output 6 | transmission | signal | Trans Temp typ. | 0.5 | 18 | See Table 8, Allison 164 |
| 29 | Prog. Output 7 | transmission | signal | Neutral Indicator Output | 2 | 18 | See Table 8, +12V neutral indicator |
| 30 | reference | vehicle | reference | +12V ignition signal | 5 | 18 | +12V ignition reference |
| 31 | Prog. Output 8 | vehicle | signal | +12V secondary control signal | 2 | 18 | See Table 8, +12V signal activated when vehicle is switched to secondary control mode |

Chassis Side Connector: HDP24-24-31SE
Body Builder Connector: HDP26-24-31PE

11/03/2020

f547386

Fig. 9, Pin Assignment and Power Definition for 31-Contact Connector (Powertrain)

11/4/2020
CAL FTL 54-013

| TABLE 7: ENGINE PIN FUNCTIONALITY BY MODEL | | | | | | |
|--|--------|--------------------|--|---------------------------------------|--|---|
| Connector Name | Cavity | Pin | Cummins | Detroit Diesel | Extended Definition | Method |
| Powertrain | 3 | Throttle Limit | 2016 Diesel ISB/C/L pin 66; 2016 ISL/G pin 12(31-way): Max engine speed OR road speed/gov. | CPC 5 Throttle Limiter 0 (CPC 5-1/11) | Engine speed will be limited to programmed value. With a Cummins engine, this input may also be used to limit road speed limit. These two features are currently mutually exclusive. | Short to Pin 9. |
| Powertrain | 4 | Throttle Advance | 2016 Diesel ISB/C/L pin 94; 2016 ISL/G pin 23(31-way): Remote PTO On/Off | CPC 5 Remote VSG Select (CPC 5-2/9) | Engine speed will jump to programmed value. | Short to Pin 9. |
| Powertrain | 5 | J1939 | 2016 Diesel ISB/C/L pin 22 (500k); 2016 ISL/G pin A(3-way): CAN H | CAN H | CAN H | Back-bone with movable terminating resistor; Note: CAN wires must be labeled indicating baud rate used. |
| Powertrain | 6 | J1939 | 2016 Diesel ISB/C/L pin 46 (500k); 2016 ISL/G pin B(3-way): CAN L | CAN L | CAN L | Back-bone with movable terminating resistor; Note: CAN wires must be labeled indicating baud rate used. |
| Powertrain | 7 | Throttle Interlock | 2016 Diesel ISB/C/L pin 93; 2016 ISL/G pin 13(31-way): Accelerator Interlock | CPC 5 Throttle Inhibit (CPC 5-1/17) | This will disable the primary accelerator. | Short to Pin 9. |
| Powertrain | 8 | Road Speed Limit | 2016 Diesel ISB/C/L pin 66; 2016 ISL/G pin 12(31-way): Max engine speed OR road speed/gov | CPC 5 Throttle Limiter 1 (CPC 5-2/11) | Road speed will be limited to programmed value. With a Cummins engine, this input is mutually exclusive with Cavity 3. | Short to Pin 9. |
| Powertrain | 9 | Input Common | 2016 Diesel ISB/C/L pin 62; 2016 ISL/G pin 19(31-way): ECM switch return | ECM Switch Return | Reference for Switches (+ or - by OEM) | Source for input signals. Note: Wire must be labeled indicating + or - source. |
| Powertrain | 10 | Input 3 | 2016 Diesel ISB/C/L pin 90; 2016 ISL/G pin 9(31-way): CC/PTO On/Off | CPC CC On/Off (CPC 5-1/14) | Reserved: This cavity is not required for all applications. It is reserved as an optional input for applications that will utilize this feature. This will enable Road speed control while moving. Or will enable engine speed control while parked or at low speed. | Short to Pin 9. |
| Powertrain | 11 | Input 4 | 2016 Diesel ISB/C/L pin 12; 2016 ISL/G pin 8(31-way): CC/PTO Set | CPC CC Set/Coast (CPC 5-1/12) | Reserved: This cavity is not required for all applications. It is reserved as an optional input for applications that will utilize this feature. This will set or decrease road or engine set speed. | Short to Pin 9. |
| Powertrain | 12 | Input 5 | 2016 Diesel ISB/C/L pin 19; 2016 ISL/G pin 7(31-way): CC/PTO Resume | CPC CC Resume/Accelerate (CPC 5-1/16) | Reserved: This cavity is not required for all applications. It is reserved as an optional input for applications that will utilize this feature. This will resume from a dropout of cruise or engine speed control or will increase set speed. | Short to Pin 9. |

11/03/2020

f547387

Fig. 10, Engine Pin Functionality by Model

To correct for this, two overlays will be added to the vehicle.

Schematics referenced for these work instructions include G66-07101-004 and G66-09942-001. BOM content is located in 33U and 160. Related installation prints are available in BOM content.

1. Remove harness A66-10959-007 from the 6 pin connector VEH_INTFC_FLR_O_DASH_4A and from the 31 pin connector VEH_INTFC_O_CUST_6A. See **Fig. 11** from schematic G66-07101-004.

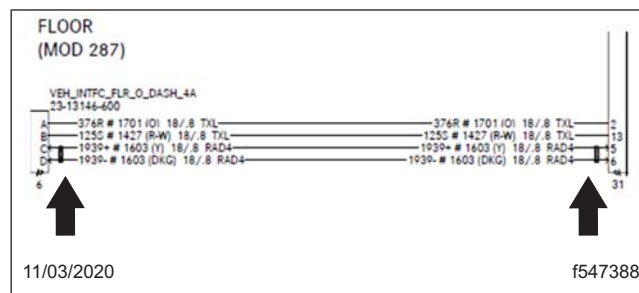

11/03/2020

f547388

Fig. 11, Remove Harness A66-10959-007

2. Remove harness A66-08440-000 from the 6 pin VEH_INTFC_DASH_O_FLR_4A connector. See **Fig. 12** from schematic G66-07101-004.

11/4/2020
CAL FTL 54-013

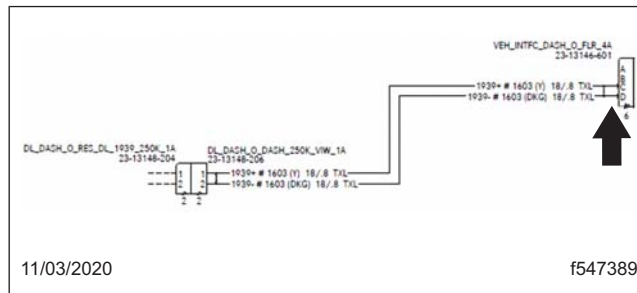

Fig. 12, Remove Harness A66-08440-000 from the VEH_INTFC_DASH_O_FLR_4A Connector

- If not present, add harness A66-10960-"L" ("L" designates the length of the harness: -007 for day cab, -032 for extended cab, -060 for crew cab) in FLR_H_UCAB_1A and VEH_INTFC_FLR_O_CUST_6A between pins 54/55 and 5/6. See Fig. 13 from schematic G66-07101-004.

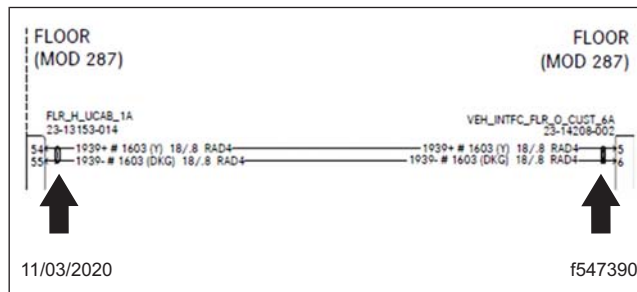

Fig. 13, If Not Present, Add Harness A66-10960-"L"

- If not present, add harness A66-07820-000 in VEH_INTFC_UCAB_O_CHAS_F_1A UCAB_H_FLR_1A between pins 8/9 and 54/55. See Fig. 14 from schematic G66-07101-004 and G66-09942-000.

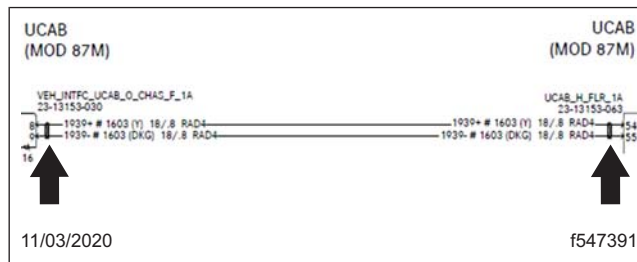

Fig. 14, If Not Present, Add Harness A66-07820-000.

