



Service Bulletin

Bulletin No.: 20-NA-211

Date: October, 2020

INFORMATION

Subject: 2021 Cadillac Escalade New Model Features

Brand:	Model:	Model Year:		VIN:		Engines:	Transmissions:
		From:	To:	From:	To:		
Cadillac	Escalade Models	2021	2021	All	All	6.2L, V8, DI, DFM, ALUM, GEN 5 — RPO L87 3.0L, L6, DOHC, TURBO Diesel, ALUM, CSS50V — RPO LM2	AUTO 10 SPD, 10L80, ATSS, ETRS, CPA, GEN 2 — RPO MQC)

Involved Countries and Regions	North America, Saudi Arabia, Columbia
---------------------------------------	---------------------------------------

General Information



5660153

2021 Cadillac Escalade

Bulletin Purpose

This purpose of this bulletin is to introduce the redesigned 2021 Cadillac Escalade.

This bulletin will help the Service Department Personnel become familiar with the engines, transmission, brake system and some of the other vehicle systems.

Overview

The 2021 Cadillac Escalade is delivering leading technology and precisely engineered features. The vehicles offer a broad range of trim levels and options and two different powertrain combinations: the all-new 3.0L Duramax turbo-diesel and the updated 6.2L engine with dynamic fuel management. All powertrains are equipped with a standard 10-speed transmission with push-button electronic shift. These vehicles also feature an all-new independent rear suspension, an optional air ride adaptive suspension, and an all-new power sliding console with a built-in cooler.

Exterior Features

Steel/Aluminum Structure

The 2021 Cadillac Escalade exterior features include a new, thicker steel frame, a lighter frame body, and aluminum closures. The structure uses a mix of materials including advanced high strength steel, high strength steel, steel, and aluminum.

Panoramic Sunroof



5619516

The 2021 Escalade features an all-new panoramic power sunroof that allows for greater light and a sense of openness in the cabin. The panoramic sunroof also includes a power sunshade cover.

The power panoramic sunroof system operates only when the ignition is turned to the RUN or Accessory positions; this allows for retained accessory power control of the sunroof and sunshade through the BCM. Once the ignition switch is turned to OFF, the sunroof and sunshade continue to operate until any door is opened or when the retained accessory power times out.

The sunroof and sunroof shade switch assembly contain two rocker-type switches that are used to control the sunroof.

Performance Features

Independent Rear Suspension

The all-new standard independent rear suspension has many advantages over the previous models. It creates a smoother ride and increases handling dynamics due to the independent wheel motion and optimized rear suspension geometry. The independent rear suspension also enables a more natural seating position for passengers in the third row, creating a more comfortable seating experience, particularly for adults, as well as greater cargo area and volume.

Air Ride Adaptive Suspension

Note: The vehicle will not lower when exiting if the level switch is in Off-road, or tow-haul/trailing mode.

The 2021 Escalade features an all-new, first-in-class, active automatic level control suspension. The air suspension improves ground clearance for off-road driving conditions. The variable-rate air springs allow a driver selectable ride height. While engaged, the Escalade AT4 can be raised 25.4 mm (1 in) in increased ground clearance mode or 50.8 mm (2 in) when maximum ground clearance mode is selected. The underside offers skid plates for chassis and suspension component protection from road debris.

Interior Features

Interior Volume

The Escalades length has been stretched to increase rear seat room. In addition, the SUVs are slightly wider and taller as compared to previous models. The independent rear suspension architectural change enables a natural seating position for passengers in the third row. Short wheelbase models now have more cargo volume behind second and third row seating areas. The third row leg room increases by 254 mm (10 in) and cargo space increases 66% over the previous generation vehicles.



5619517

1. 254 mm (10 in) Additional Third Row Legroom
2. 66% Additional Cargo Space Behind Third Row Seating

Multicolor Head-Up Display



5619518

A new, available multicolor head-up display projects key, customizable vehicle data on the windshield in a 76.2 by 177.8 mm (3 by 7 in) display to help drivers keep their eyes on the road.

Power Sliding Console

The 2021 Escalade features the first-ever optional power sliding center console in the large SUV market. The center console can slide backwards up to 254 mm (10 in) to enhance overall storage flexibility and organization. A power rocker switch in the center overhead console operates the power slide functionality. In addition, there is a hidden storage drawer that can be secured when in valet mode.

Brakes Systems

Brake System Overview

The 2021 Cadillac Escalade features an integrated brake control system, including an electro-hydraulic boost system that replaces the conventional vacuum-based power assist brake system. The electro-hydraulic brake system supplies on-demand power when the driver presses the brake pedal. The 2021 Escalade features 4-wheel, 17-inch disc brake rotors as standard equipment. The brakes are equipped with a new brake pad lining wear sensor system and an electronic parking brake system.

Antilock Braking System

The Antilock Braking System (ABS) is equipped with the integrated brake control system. Integrated brake control relies upon an electromechanical device that includes a brake system control module. The module interprets and converts driver input and provides a corresponding hydraulic pressure output to activate a standard brake system according to the driver's demand. In an event of no electrical energy or failure condition, the driver's input is mechanically converted to a hydraulic pressure output.

Compared to conventional brake apply systems, the integrated brake control enables additional brake pressure and provides additional brake system features.

Antilock Braking System Components

The following vehicle systems and components work in conjunction with integrated brake control:

Body Control Module

The Body Control Module (BCM) monitors the brake pedal position sensor signal when the brake pedal is applied. Then the BCM sends a high-speed serial data message to the brake system control module, indicating the brake pedal position.

Instrument Cluster

The instrument cluster displays the vehicle speed based on the information from the Engine Control Module (ECM). The ECM communicates the vehicle speed information via a high speed serial data message to the BCM. The BCM then communicates the vehicle speed information via a low speed serial data message to the instrument cluster. Speed is displayed in kilometers per hour (km/h) or miles per hour (MPH), based on the vehicle settings.

Multi-axis Acceleration Sensor

The yaw rate, lateral acceleration, and longitudinal acceleration sensors are combined into one multi-axis acceleration sensor, internal to the inflatable restraint sensing and diagnostic module. The brake system control module receives yaw rate, lateral acceleration, and longitudinal acceleration inputs from the multi-axis acceleration sensor via serial data. The module activates stability control and the hill hold start assist function depending on multi-axis acceleration sensor input.

Traction Control Multifunction Switch



5619519

The BCM monitors the signal circuit from the traction control multifunction switch (shown circled above). The BCM communicates a high speed serial data message to the brake system control module, indicating the

switch position. The traction control and stability control are manually disabled or enabled by pressing the traction multifunction control switch.

Steering Wheel Angle Sensor

The brake system control module receives serial data message inputs from the steering angle sensor. Steering wheel rotation speed and direction are calculated to determine the intended driving direction and any abrupt or evasive maneuvers. The steering wheel angle sensor is an internal component of the power steering gear.

Transmission Control Module

The brake system control module receives high speed serial data message inputs from the transmission control module, indicating the gear position of the transmission for hill start assist or hill hold functions.

Wheel Speed Sensors

Unique directional wheel speed sensors can detect wheel direction as well as zero wheel speed. The wheel speed sensors receive a 12 volt power supply voltage from the brake system control module and provide an output signal to the module. As the wheel spins, the wheel speed sensor sends the brake system control module a direct current (DC) square wave signal. The brake system control module uses the frequency of the square wave signal to calculate the wheel speed.

Power-Up self-Test

The brake system control module is able to detect many malfunctions whenever the ignition is ON. However, certain failures cannot be detected unless active diagnostic tests are performed on the components. Shorted solenoid coil or motor windings, for example, cannot be detected until the components are commanded ON by the brake system control module. Therefore, a power-up self-test is performed to verify correct operation of system components. The brake system control module performs the first phase of the power-up self-test when the ignition is first turned ON. This phase consists of internal self-testing of the brake system control module along with electrical checks of system sensors and circuits.

Disconnecting the 12V battery is the only method that ensures a self-test will not occur while servicing the brakes. The self-test consists of an internal hydraulic test of the brake master cylinder and an external hydraulic leak test of the brake lines and calipers. The self-test pressurizes all four circuits leading to the calipers.

Antilock Brake System Performance Enhancement Systems

Depending on options, the following ABS performance enhancement systems may be provided:

- brake assist features
- panic brake assist
- hydraulic fade compensation
- rear brake boost

- electronic pre-fill
- motor-on-caliper torque overlay
 - electronic stability control features
- roll over mitigation/pre-emptive electronic stability control
- torque vectoring by brakes
- flat tire electronic stability enable
- electronic stability control with vehicle weight estimation
 - traction control
- vehicle stuck control
- power hop control
- engine drag control
- enhanced off-road control
 - integrated brake control system
- brake drying/cleaning
- hill start assist
- driveline damping
- extended hill hold start assist
- automatic vehicle hold
- vehicle moding
- hill descent control
 - brake pad life monitoring
 - electric parking brake

Brake Assist Features

Brake assist provides additional brake pressure and brake system features compared to conventional brake apply systems.

Panic Brake Assist

This feature applies the brakes more quickly when a panic brake situation is determined. Panic brake assist detects that the driver's intent is to stop the vehicle as quickly as possible but the driver is not applying sufficient brake pressure to do so. The feature detects the driver's intent and then actively applies brake pressure to maximum pressure, thus activating the ABS system and stopping the vehicle as quickly as possible.

Hydraulic Fade Compensation

The hydraulic fade compensation increases brake system pressure above the driver-applied brake pressure when the brake system determines a gross fade condition. The conditions are based on the following conditions:

- brake disc/pad temperature estimate
- driver-applied master cylinder pressure
- vehicle deceleration rate

The goal of providing additional brake system pressure is to reduce stopping distance during high deceleration requests from the driver. The driver experiences fading brakes while using low or medium brake pedal force application. The hydraulic fade compensation only activates during high brake pedal force application.

Rear Brake Boost

Rear brake boost provides rear hydraulic brake assist to ensure all four wheels are achieving maximum braking during an ABS event. When vehicle loading is heavily rear axle biased, the rear brakes may not utilize all of the available road adhesion. The hydraulic rear brake boost design provides additional braking pressure to the rear brakes when the front brakes are using the ABS and the rear wheels are in a low slip condition.

Electronic Pre-fill

This feature reduces the brake response time when the driver quickly releases the accelerator pedal. In addition, this feature supports the use of low drag calipers.

Motor-on-Caliper Torque Overlay

This feature reduces the driver's braking effort when in backup (no power) mode. The operation of this feature includes torque being applied with the electric park brake motors on the front or rear calipers, preferably isolating that hydraulic circuit, to provide assist. When in this mode, the electric park brake motors apply torque based on the driver's commanded deceleration, instead of clamping to a certain force.

Electronic Stability Control Features

The electronic stability control system uses ABS capabilities to minimize oversteer and understeer conditions. This system uses inputs from a multi-axis sensor and a steering angle sensor to ensure that the vehicle continues traveling in the intended direction of driver steering input. The electronic stability control system applies the individual brakes selectively to minimize oversteer or understeer. The driver may disable electronic stability control by using the disable switch in the center console.

The electronic stability control system include the following features:

Roll Over Mitigation/Preemptive Electronic Stability Control

The electronic stability control system features use the standard sensor set. Roll over mitigation detects driving situations that may cause a vehicle rollover. When a potential rollover condition is detected, the electronic stability control system is activated to reduce the chance of vehicle rollover.

Torque Vectoring by Brakes

Torque vectoring by brakes enhances vehicle agility by using brake applies and engine torque requests to maximize traction on drive wheels. While cornering, brakes are applied to the inside drive wheels, thus allowing more torque to the outside wheels without slipping the inside wheels. Increasing the engine torque, above driver request, gives more torque to the outer wheels. This feature is designed to improve high cornering maneuvers and also allows for an all-around increase in performance.

Trailer Sway Control

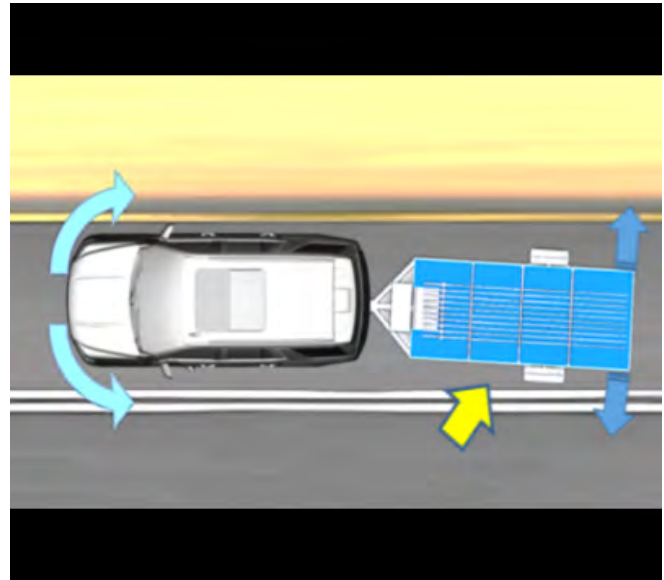

5619520

Trailer sway control uses the electronic stability control system to detect trailer instability and apply differential braking to dampen out trailer oscillation and instability. If trailer sway control detects repeated trailer instability, it communicates to a display device to warn the driver of an unsafe trailer setup.

Flat Tire Electronic Stability Enable

Once a flat tire is detected, electronic stability control cannot be disabled. If the electronic stability control system was previously disabled, it can be re-enabled to assist with stability. However, turning off the traction control system is permissible.

Electronic Stability Control with Vehicle Weight Estimation

The brake system control module has the capability to estimate vehicle weight while the vehicle is being driven. This feature may modify the electronic stability control system based on estimated vehicle weight when a compact spare tire is detected on the rear axle.

Traction Control System Features

The traction control system includes the following features:

Vehicle Stuck Control

The traction control system detects a vehicle stuck condition by monitoring excessive wheel slip for greater than 5 seconds with a vehicle reference velocity of less than 3 km/h (1 MPH). Once detected, the traction control system allows additional wheel slip of 5% to help get the vehicle unstuck. This feature does not guarantee to recover the vehicle from a stuck condition; it is only intended to assist the driver.

Power Hop Control

Power hop is an oscillation of the driven wheels due to a rapid acceleration on high coefficient surfaces. Wheel oscillation results in a vehicle bounce, and driver discomfort, failure of driveline components, and potentially other damage to the vehicle. This feature

detects the power-hop by monitoring the wheel speed sensor signal, and the traction control system will attenuate the power-hop by reducing engine torque and applying brake pressure. If the traction control system is off, the brake system control module and engine control module may mitigate the power hop condition.

Engine Drag Control

This feature is designed to mitigate drop-throttle oversteer or understeer when the vehicle speed is above 18 km/h (12 MPH).

While applying throttle during maximum cornering on a rear-wheel drive, the vehicle could exhibit an oversteer situation if the driver quickly releases the throttle. If this condition is detected, engine torque is slowly reduced in order to maintain vehicle stability.

Enhanced Off-Road Control

The intent of this feature is to maximize rock crawling capability when the vehicle is in Off-Road mode or 4LO transfer case mode. The traction control calibration is then biased towards low-speed, active capability by applying more brake control with less wheel slip.

Brake System Control Module Features

The brake system control module includes the following features:

Brake Drying/Cleaning

Brake drying/cleaning autonomously applies a small amount of brake pressure during long periods of driving on wet roads in order to remove water from the rotor surface. The brake application is transparent to the driver and results in improved brake feel and performance. Conditions to enable brake drying/cleaning include:

- wipers on
- brake pressure build up to 3 bar (43.5 psi) at all four wheels

If cruise control is active, brake drying/cleaning will not function, as minimum pedal position is required. If the driver brakes, the distance counter resets.

Hill Start Assist

The hill start assist feature temporarily holds the vehicle while on a grade for 2-5 seconds after the driver removes their foot from the brake pedal and the vehicle is on a grade exceeding 7%. The intent of this feature is to prevent the vehicle from rolling down the hill before the driver has an opportunity to apply the accelerator pedal.

Driveline Damping

Driveline damping is required on vehicles with electronic stability control, stop/start functionality, and an automatic transmission. This feature holds brake pressure to dampen driveline acceleration disturbance as the engine is restarted and holds brake pressure to retard or prevent the vehicle from rolling. It is used for driver comfort and to extend vehicle hold on a steep grade.

Extended Hold Hill Start Assist

The extended hold hill start assist feature functions the same as hill start assist, except this feature allows an indefinite vehicle hold rather than the temporary hold provided by hill start assist alone.

Automatic Vehicle Hold

Automatic vehicle hold is a driver-enabled feature that holds the vehicle at a standstill for an indefinite amount of time. This feature is similar to the extended hold hill start assist, but functions on all road grades. This feature must be enabled by the driver and reverts to a disabled state upon restarting the vehicle. The brake system control module holds the vehicle and then transfers the hold to the electric parking brake as necessary.

The automatic vehicle hold function requires the vehicle to have an electronic parking brake, which allows the brake pressure hold time to increase for up to 5 minutes before engaging the electronic park brake. Automatic vehicle hold is available on vehicles with an automatic transmission and is only available on vehicles with a manual transmission if equipped with a neutral gear position indicator (start/stop engines have neutral gear position indicator).

Vehicle Moding

The brake system control module uses the driver-selected mode status signals to determine which mode the vehicle is in. Mode 0 corresponds to NORMAL mode and is the default. Other supported modes are: SPORT, OFF-ROAD, TRACK, SNOW/ICE, and TOW/HAUL.

Hill Descent Control

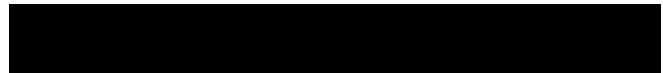

5619521

Hill descent control allows vehicles with an automatic transmission, to travel on a steep decline without pressing the brake pedal at speeds between approximately 5-30 km/h (9-19 MPH). Hill descent control is enabled by activating the hill descent control switch (shown circled above) at a vehicle speed below the maximum enabling vehicle speed.

The grade activation minimum threshold is 10%, when activated; the system maintains the desired descent speed when the vehicle is on a steep slope.

The descent speed can, however, be varied by using the accelerator or brake pedals.

Brake Lining Wear Life Indicator (JBK)

2021 Cadillac Escalade features a new brake pad lining wear sensor system that estimates the remaining life of the front and rear brake pads. When the feature is active, brake pad life percentage is displayed in the driver information center, along with a distance for each axle.



5619522

When the system has determined that the brake pads need to be replaced, a message displays that may include mileage remaining. In addition, the system actively reminds the driver to take action at ignition cycle intervals.

If the feature malfunctions, a fault message displays in the driver information center. The feature may be disabled, if desired, and confirmation will then appear in the driver information center.

The brake system control module has one analog input for a front axle brake pad wear sensor and one analog input for a rear axle brake pad wear sensor. Both sensors are located on the left side of the vehicle. The brake system control module supplies voltage to the brake pad wear sensor, and the sensor is grounded to the vehicle ground. The brake system control module diagnoses any issues with the power supply for the sensors. If a failure is detected in the supply voltage system, the module sets an INVALID message.

After replacing the brake pads, the axle brake pad life monitor reset learn must be performed.

The brake pad life system can be turned off. This may be necessary if aftermarket brake pads without wear sensors are installed. When the system is turned off, the front and rear brake pad life percentages will not display.

Electric Parking Brake



5619523

The 2021 Escalade is equipped with an electric parking brake. A switch on the instrument panel (shown circled above) takes the place of the foot pedal and release handle of a manual parking brake system.

Electric Park Brake Components

The parking brake function is integrated into the electronic brake control module. The electronic brake control module contains the logic for applying and releasing the parking brake when commanded by the park brake switch.

The park brake switch is a push-button style switch; when pressed, a signal is sent to the electronic brake control module. The electronic brake control module then supplies 12 V to the apply control circuits and ground to the release control circuits, commanding both rear park brake actuators to activate and engaging the park brakes. When the park brake switch is pressed a second time, a signal is sent to the electronic brake control module, which supplies 12 V to the released control circuits and a ground to the apply control circuits to release both park brake actuators.

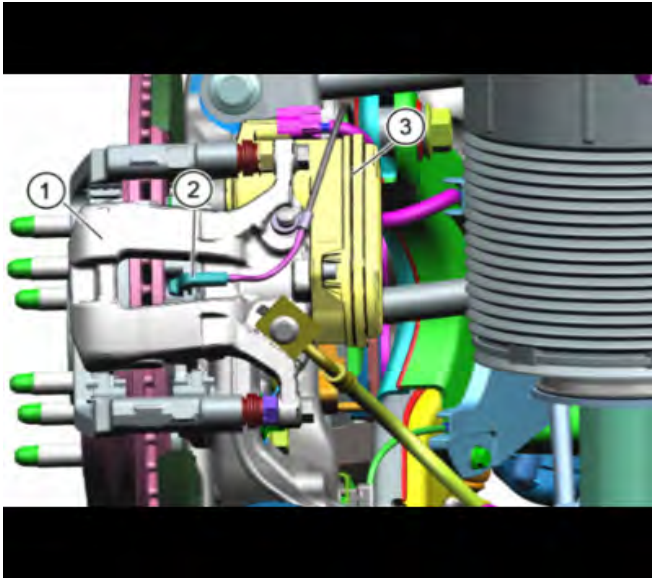

5619524

1. Rear Brake Caliper
2. Rear Brake Pad Wear Sensor
3. Rear Park Brake Actuator

Left Rear Brake Caliper and Park Brake Actuator

The electric parking brake interfaces with the following systems in varying situations:

Dynamic Braking with Electric Parking Brake

Dynamic braking with the electric parking brake provides autonomous braking when the electric parking brake switch is pressed while the vehicle is in motion. This feature also allows the brake control module to apply braking to all four wheels until the vehicle comes to a complete stop. Next, the electric parking brake applies and the brake control module releases pressure.

Electronic Transmission Range Select (ETRS) Autonomous Apply

This feature applies brake pressure on a request from the ETRS. This is temporary until the electric parking brake can apply, using the ETRS electric parking brake apply feature.

The brake control system provides a short service brake hold to prevent the vehicle from rolling between when the ETRS commands a hold and the electronic park brake is applied. The primary purpose of the ETRS/brakes interface is to apply the park brake when an ETRS malfunction prevents the transmission from going into PARK; or if the driver shifts to PARK on a grade, the electric parking brake reduces the load on the transmission park pawl. The ETRS calculates and calibrates this grade.

Electric Parking Brake Service Considerations

The electronic brake control module monitors the park brake motor circuits to verify proper functionality. The park brake motor circuits are used to command actuator motor operation, which applies and releases the parking brake. If the red park brake light flashes, the electric parking brake is partially applied or released. If there is a malfunction in the electric parking brake

system, the SERVICE PARK BRAKE message is displayed and a Diagnostic Trouble Code (DTC) sets in the control module. The park brake system is disabled as long as a DTC is set.

The vehicle may automatically apply the electric parking brake in some situations when the vehicle is not moving. This is a normal condition and is part of a self-test to verify correct operation of the electric parking brake motor operation to apply and release the parking brakes.

In the event of an electrical malfunction or insufficient electrical power, the electric parking brake cannot be applied or released.

Each park brake motor has an integrated position sensor to monitor the park brake motor position.

Electric Parking Brake Apply

The electric parking brake can be applied any time the vehicle is stopped or in motion. The electric parking brake is applied by momentarily pressing on the park brake control switch. The red park brake light momentarily flashes while the parking brake is being applied. Once fully applied, the red park brake light stays on. If the electric parking brake is applied while the vehicle is in motion, a chime sounds, and the message displays Release Park Brake Switch.

Electric Parking Brake Release

To release the electric parking brake:

1. Turn the ignition switch to the ON or RUN position.
2. Apply and hold the brake pedal.
3. Push down momentarily on the park brake control switch.

When the electric parking brake releases, the red park brake light turns off.

Engine

Overview

The 2021 Cadillac Escalade is available with a variety of powertrain combinations. Available engines include the new diesel 3.0L (LM2) I6, and the gas powered 6.2L (L87) Gen 5 V8 engine with a new, dynamic active fuel management system. The stop/start system is included with the 3.0L (LM2) I6 and 6.2L (L87) V8 engines.

3.0L (LM2) I6 Diesel Engine

The 3.0L (LM2) turbocharged in-line 6-cylinder diesel engine is part of the Cylinder Set Strategy (CSS) family of engines, which deliver reduced friction, weight, and exhaust emissions, while at the same time delivering fuel economy that surpasses the engines they replace. The turbocharger system includes an electronically operated wastegate valve and provides good low-end torque as well as high-end performance.

The engine also incorporates the following technologies:

- variable geometry turbocharger
- active thermal management
- stop/start
- low pressure Exhaust Gas Recirculation (EGR)

- variable intake manifold
- variable pressure oiling system

3.0L (LM2) I6 Engine Specifications

- **Engine Type:** Diesel Inline 6-Cylinder Dual-Overhead Camshaft (DOHC)
- **Displacement:** 3.0L(183 CID)
- **Bore x Stroke:** 84.0 mm x 90 mm (3.307 in x 3.543 in)
- **Block Material:** Aluminum w/iron cylinder liners
- **Cylinder Head Material:** Aluminum
- **Compression Ratio:** 15:1
- **Firing Order:** 1-5-3-6-2-4
- **Horsepower (@ 3750 RPM)** 207 kW (277 HP)
- **Torque (@4000 RPM)** 624 Nm (460 lb ft)

Crankshaft

The crankshaft is made of forged micro alloy steel. Four counterweights are scalloped for mass reduction and topped for precise engine balance. The crankshaft is supported by seven main journals with the sixth bearing being the crankshaft thrust bearing. The oil pump sprocket and the crankshaft reluctor ring are press fit on the rear of the crankshaft. The sprocket for the primary chain drive is machined into the rear of the crankshaft.

Piston and Connecting Rod Assembly



5619525

The piston and connecting rod assembly consist of forged steel connecting rods and cast aluminum pistons. Pistons incorporate a polymer-coated skirt to reduce friction. They also incorporate two low tension compression rings along with one multi-piece oil control ring. The connecting rods and rod caps are aligned by machined serrations and dowel pins retained in the cap.

Cylinder Block

The aluminum alloy cylinder block features six cast-in-place iron cylinder liners. The main caps are ductile iron and include six main cap bolts per cap. To

prevent aeration, oil that returns from the valve train and cylinder heads is channeled away from the rotating and reciprocating components through oil drain back passages. These passages are incorporated into the cylinder heads and engine block. Pressure-actuated piston oil cooling jets are mounted between opposing cylinders. The engine has four knock sensors with two sensors located on each side of the engine block.

Cylinder Head

The cast aluminum alloy cylinder head features a dual overhead camshaft and a two-piece design. Two intake valves and two exhaust valves are actuated by roller finger followers pivoting on a stationary hydraulic lash adjuster. The cylinder heads also feature a high-tumble port design with sodium-filled exhaust valves for high temperature operation in the turbocharged environment.

Separate exhaust and intake camshafts are supported by bearings machined into the camshaft carrier. The front camshaft bearing cap is used as a thrust control surface for each camshaft.

The high pressure fuel injectors are located within machined bores below the intake ports. A stainless steel, high pressure fuel rail is attached to the intake side of the head.

Head gaskets are available in three different thicknesses, depending upon the piston protrusion measurements.

Camshafts

The 3.0L LM2 uses two camshafts, one to actuate all intake valves and the other to actuate all exhaust valves. The camshafts are driven by the camshaft sprockets, which in turn are driven by the secondary timing chain.

The intake and exhaust camshafts mount to the camshaft housing ladder frame assembly. The valve train uses a roller finger follower acted on by a hydraulic lash adjuster. The roller finger follower reduces friction and noise.

Active Thermal Management Cooling System

New to the 2021 Escalade is an active thermal management system that helps the engine warm up and achieve its optimal engine temperature more quickly. The system eliminates the need for a conventional thermostat. A rotary valve system is used to distribute coolant through the engine in a targeted manner.

Mechanical Water Pump

The mechanical water pump is mounted on the right side of the engine. Coolant flows from the mechanical water pump into the engine cylinder block and cylinder head. The mechanical water pump also provides cooled coolant flow from the radiator directly to the engine coolant flow control valve. Inputs from various temperature and position sensors are used by the Engine Control Module (ECM) to direct the flow of coolant from the engine coolant flow control valve to either heat or cool as necessary. A de-gas circuit is incorporated into the engine cylinder block and head that moves any trapped air bubbles to the surge tank.

Coolant Flow Control Valve

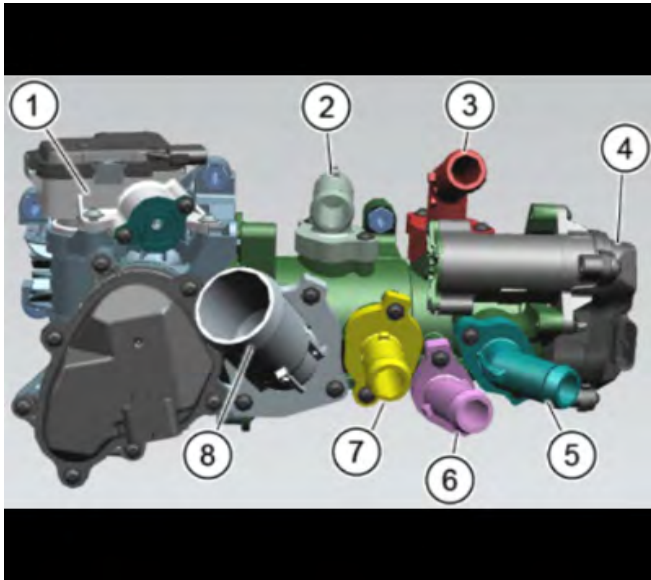

5619526

1. Block Valve
2. EGR 1
3. EGR 2
4. Rotary Valve
5. Water Pump
6. Engine Oil Cooler
7. Bypass
8. Radiator

The main component of the active thermal management system is the engine coolant flow control valve. The engine coolant flow control valve has two actuators, a block control valve, and a main rotary valve. The control valve attaches to the engine block under the intake manifold. The valve consists of one rotary valve and two chambers. The first chamber controls the coolant flow rate across the radiator and bypass. The second chamber controls the flow to the transmission and engine oil cooler, providing hot water from the EGR/turbocharger return or cold coolant directly from the water pump outlet. The EGR feed port is uncontrolled and is always open.

Temperature Sensors

Coolant temperature and engine oil temperature sensors are monitored at multiple different locations, including the following:

- engine block coolant sensor
- engine cylinder head coolant sensor
- engine coolant inlet and outlet sensors
- radiator outlet sensor
- cabin heater core inlet and outlet
- oil temperature sensors 1 and 2
- transmission oil temperature sensor

Auxiliary Coolant Pump

The auxiliary coolant pump receives coolant from the cabin heater core and the cylinder head bypass circuit. The pump assists with moving coolant back to the engine mechanical water pump.

Modes of Operation

There are six modes of operation, including the following:

- cabin heating
- cabin heating with bypass
- cabin heating with oil warming
- demand cooling with oil warming
- demand cooling with oil cooling
- split cooling that directs coolant between the cylinder block and cylinder head

Fuel System

The Escalade uses a common rail diesel fuel injection system.

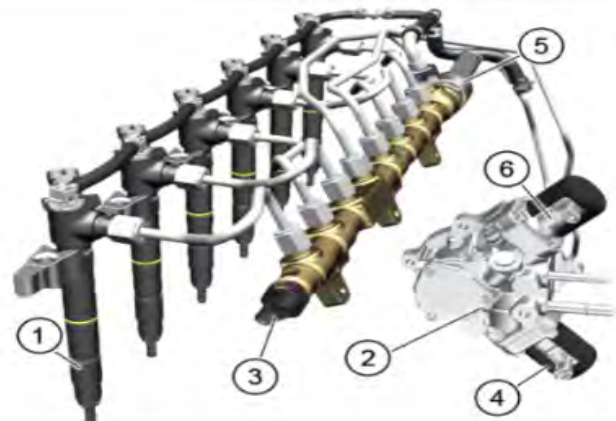

5619527

1. Q17 Fuel Injectors
2. G18 High Pressure Fuel Pump
3. B47 Fuel Pressure Sensor
4. Q18A Fuel Pressure Regulator 1
5. Q18B Fuel Pressure Regulator 2
6. Q18C Fuel Pressure Regulator 3

TOP TIER™ Fuel Requirements

GM recommends the use of TOP TIER™ Diesel Fuel to keep the engine clean, reduce engine deposits, and maintain optimal vehicle performance. Look for the TOP TIER™ logo or see www.toptiergas.com for a list of TOP TIER™ diesel fuel marketers and applicable countries.

The selection of a high-quality fuel is important for maintaining optimum vehicle performance. Diesel fuel should meet or exceed the minimum requirements in the most current versions of the local fuel standards, including the following:

- Use ultra-low sulfur fuel. Do not use fuel with more than 15 ppm sulfur.
- Do not use a diesel blend containing more than 20% biodiesel by volume.
- Do not use contaminated or dirty fuel, which may decrease fuel filter life. Contaminated or dirty fuel may also cause a CHANGE FUEL FILTER message to display on the driver information center.

Below are some examples of improper fuels:

- diesel fuel with the addition of gasoline
- diesel fuel mixed with engine oil or automatic transmission fluid
- triglyceride fuels, such as raw vegetable oil or animal fat, in any form, including with blends of diesel or biodiesel
- marine diesel fuel and fuel oils
- diesel-water emulsions, such as Aquazole™
- aftermarket diesel fuel additives, which contain alcohols, organo-metallic additives, or water emulsifiers

Climate Grade Diesel Fuels

At temperatures below 0°C (32°F), avoid using biodiesel blends above 5% by volume. Using such a fuel may cause fuel filter plugging, system gelling, and freezing, which may adversely affect vehicle starting.

Severe winter grade diesel fuel, such as 1-D diesel fuel or arctic grade diesel fuel, can be used in extreme cold temperatures (below -18°C or 0°F); however, doing so reduces engine power and fuel economy. Avoid using severe winter grade fuel in warm or hot climates, as it may result in stalling, hard starting, and damage to the fuel injection system.

Fuels improperly blended for cold temperature operation may result in restricted fuel filters. The vehicle is equipped with a fuel heating system to prevent gelling or waxing of conventional diesel fuel and biodiesel blends, but may not prevent all cases.

In case of severe winter conditions, the fuel filter may become clogged by wax naturally present in the fuel. To unclog it, move the vehicle to a warm garage area and allow the filter to warm up. The fuel filter may also need replacement.

Biodiesel

Biodiesel is a renewable fuel produced from vegetable oils or animal fats that have been chemically modified to make it compatible with diesel fuel.

Biodiesel Blends

Fuels with a biodiesel content up to 20% by volume may be used (e.g., B20). Only use biodiesel blends up to 20% by volume that comply with your country's or region's fuel standards.

As a renewable fuel, biodiesel provides some environmental benefits. However, biodiesel has unique properties and needs to be handled differently than

diesel fuel. Its use presents additional risks and may not be appropriate in all situations. Certain vehicle operating modes increase these risks and should be avoided.

Biodiesel fuel quality degrades with time and exposure to high temperatures quicker than ultra-low sulfur diesel fuel. More frequent refueling provides the best opportunity to have a supply of fresh fuel. Storage at hot ambient temperatures will accelerate biodiesel degradation.

If the vehicle is not driven often and uses little fuel, or if it is stored for extended periods of time, avoid the use of biodiesel blended fuels above 5% by volume. When the vehicle is stored for longer than one month, it should be run out of biodiesel to below one-quarter tank, refueled with biodiesel-free fuel, and driven several kilometers (miles) before storage.

Fuel Injectors

The 3.0L (LM2) diesel engine incorporates solenoid-type fuel injectors that are controlled by the ECM. The injector sprays fuel directly into the combustion chamber. Each fuel injector has a high pressure fuel pipe from the fuel rail and a return line.

The fuel injection quantity estimates the actual quantity of fuel injected into the cylinder, in addition to adjusting fuel delivery if fuel injectors drift off calibration slightly as they age. Required inputs are the mass airflow sensor and Nitrogen Oxides (NOx) sensor 1 to determine the air/fuel ratio. This information is used by the ECM to correct set points for exhaust gas recirculation, boost pressure, and fuel rail pressure. The NOx sensors provide the ECM with both NOx and O2 information.

Fuel Injector Service Considerations

The solenoid-type fuel injectors require a special tool for removing the injectors from their bore. However, in extreme cases, use a slide hammer with an M6 x 1.0 thread installed in place of the fuel return banjo bolt. In such cases, ensure all force is directed straight upwards from the fuel injector.

The solenoid injectors also require a new injector bore and sleeve-cleaning kit for the engine injector bores. The cleaning kit removes carbon deposits from the fuel injector sleeve bore, which is very helpful during a fuel injector replacement.

High Pressure Fuel Pump

The high pressure fuel pump is a mechanical pump and is attached on the driver's side of the engine block. The high pressure fuel pump is driven by the timing chain. The pump provides high pressure fuel to the fuel rail at a specified pressure, regulated by the fuel pressure regulators. The high pressure fuel pump is capable of delivering more than 13 megapascals (1,885 pounds per square inch) of fuel pressure.

High Pressure Fuel Pump Service

The high pressure pump on vehicle service is similar to other small diesel engines. Access to the pump driven sprocket can be obtained by removing the fuel pump access cover. Use the special tools to retain engine timing while removing the high pressure fuel pump.

The high pressure fuel pump is timed to the engine. When replacing just the pump, the timing is retained by the tools. If the high pressure fuel injection pump-driven sprocket is removed from the engine, then the timing adjustment must be performed

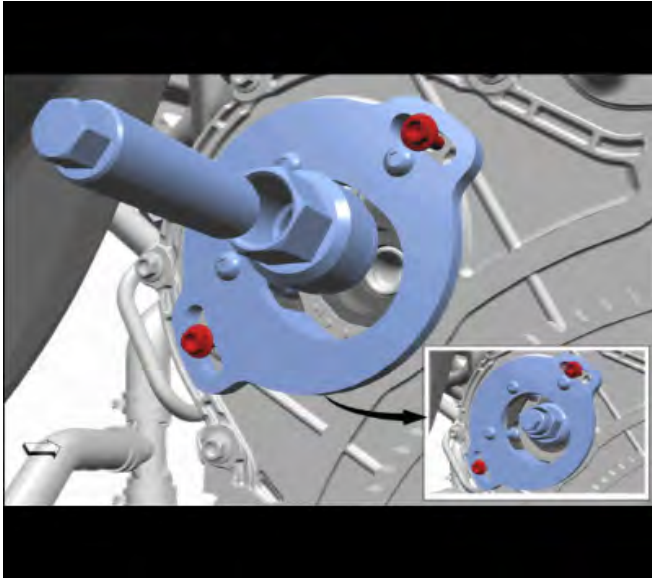

5619528

Fuel Pressure Regulators

The ECM controls the fuel rail pressure using three Pulse Width Modulated (PWM) fuel pressure regulators. Fuel pressure regulators 1 and 3 are located in the fuel injection pump and meter the amount of fuel that enters the high pressure side of the pump. The high pressure fuel pump has two pumping chambers, and each fuel pressure regulator controls the fuel entering one of the chambers.

From the high pressure pump, the fuel moves to the fuel rail through high pressure steel lines to all six fuel injectors.

Fuel pressure regulator 2 is located on the rear of the fuel rail. The ECM varies the PWM voltage to fuel pressure regulator 2 to relieve excessive fuel pressure, allowing fuel to return to the fuel tank. When the ignition is OFF, fuel pressure regulator 2 opens to bleed off the pressure on the high pressure side of the fuel system.

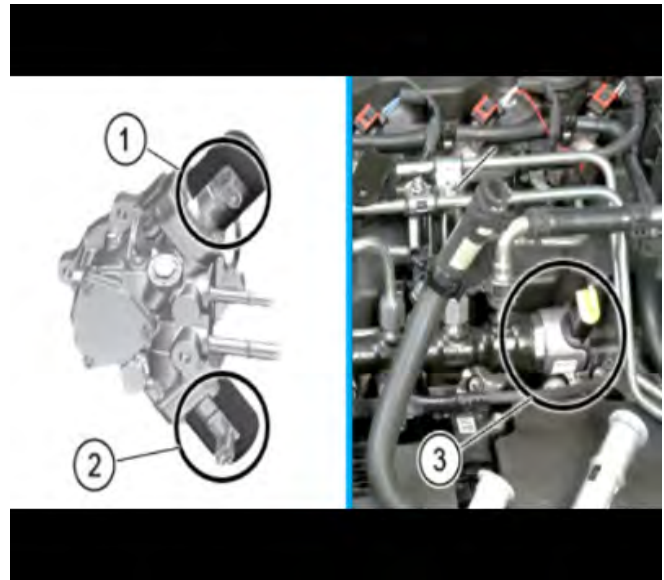

5619529

1. Fuel Pressure Regulator 1
2. Fuel Pressure Regulator 2
3. Fuel Pressure Regulator 3

High Pressure Regulators

Fuel Pressure Sensor

The fuel rail pressure sensor is located in the end of the fuel rail assembly. This dual analog sensor provides two fuel rail pressure signals to the ECM. The ECM receives a varying signal voltage on both the fuel rail pressure sensor and fuel rail pressure sensor 2 signal circuits. The ECM monitors the voltage on both of the fuel rail pressure sensor circuits and compares the values to determine if the sensors are accurate. When the fuel pressure is high, the fuel rail pressure sensor signal voltage is high and the fuel rail pressure sensor 2 signal voltage is low. When the fuel pressure is low, the fuel rail pressure sensor signal voltage is low and the fuel rail pressure sensor 2 signal voltage is high.

Turbocharger

The 3.0L (LM2) diesel engine utilizes a variable geometry turbocharger to increase the engine's power output. The variable geometry turbine position sensor assembly is mounted within the variable geometry turbine body assembly.

The ECM controls the turbocharger vane position using dedicated circuits to provide power and ground to the motor; switching the polarity reverses the direction of travel.

Variable Geometry Turbocharger Actuator

The turbocharger vane position actuator contains a sensor that reads the position of the vanes and converts this to a digital signal that is transmitted to the ECM. The ECM decodes this signal and uses the information as feedback to control the vanes.

The turbocharger vanes are normally closed when the engine is not under a load or at an idle. The ECM opens the turbocharger vanes to increase engine power and to create a high pressure using the boost pressure actuator.

At extreme cold temperatures, the ECM may close the turbocharger vanes in low load conditions in order to accelerate engine coolant heating. The ECM may also close the turbocharger vanes under exhaust braking conditions.

Charge Air Cooler

An air-to-water charge air cooler system incorporates a heat exchanger integrated into the intake manifold housing. This system reduces the engine inlet air temperature by up to 100°C (180°F), which enhances performance. The intercooler uses conventional DEX-COOL® coolant in a system that is separate from the engine cooling system. The system also includes a low temperature auxiliary radiator and a charge air coolant pump. The low temperature auxiliary radiator is also referred to as the auxiliary radiator and is located in the front fascia. Coolant is directed into and through the charge air cooler/heat exchanger. Coolant exits through the outlet port and is pumped back to the charge air cooler radiator.

Charge Air Cooler Pump

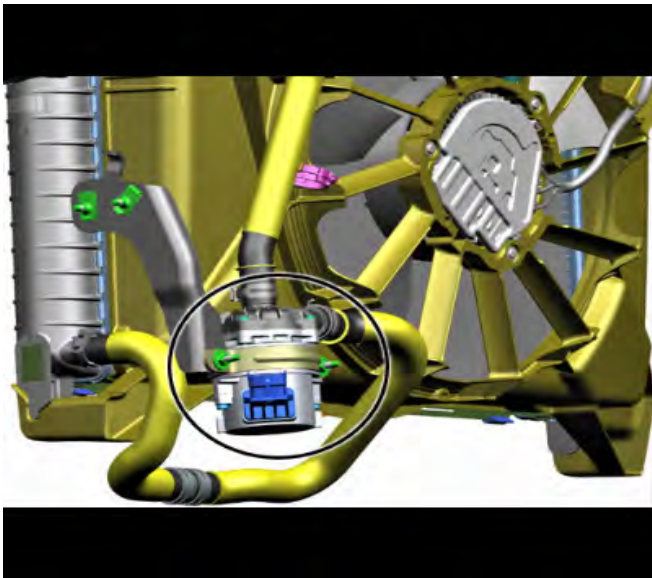

5619530

The charge air coolant pump is a solid state device. When the engine starts, the ECM sends a request via the serial data circuit to the charge air coolant pump. This causes the pump to operate at the desired speed. The charge air coolant pump provides operational and diagnostic feedback to the ECM on the serial data circuit. If a condition exists with the physical pump, or microprocessor logic, the device reports fault-specific information via the serial data circuit to the ECM. The ECM sets the corresponding Diagnostic Trouble Code (DTC) if the device fails to communicate, or if a condition exists with external circuits, the device's corresponding U-code will set.

Timing System

The 3.0L (LM2) diesel engine uses two camshafts, one to actuate all intake valves and the other to actuate all exhaust valves.

Primary Timing

The oil pump sprocket and the crankshaft reluctor ring are press fit on the rear of the crankshaft. The sprocket for the primary chain drive is machined into the rear of the crankshaft and the timing chain drives the high pressure fuel pump.

Secondary Timing

The camshafts are driven by the camshaft sprockets, which in turn are driven by the secondary timing chain.

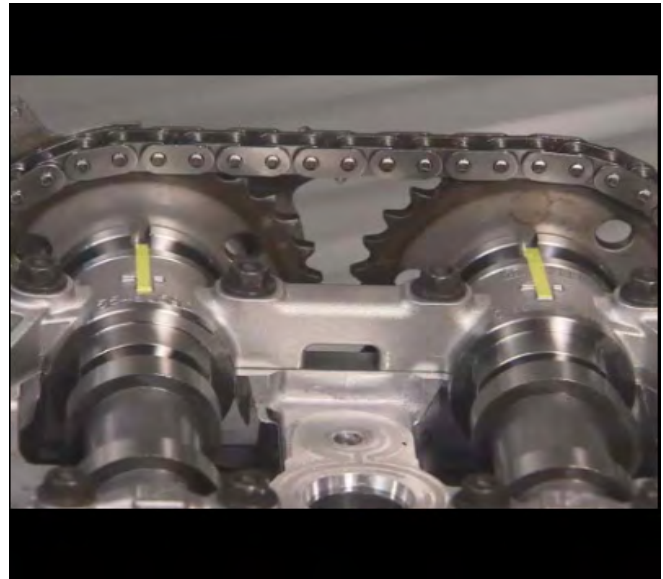

5619531

Camshaft removal and installation require special tools to hold the crankshaft and camshaft in alignment.

1. To install the crankshaft tool properly, the locking hole in the counterweight must be aligned with the hole in the front of the block.
2. Rotate the engine until the holes align.
3. Install the tool. Make sure that the arrows on the cam ladder frame line up with the notches on the ends of the camshafts.

Oil Pump and Oil Pump Drive

The oil pump is driven by the engine crankshaft by a wet belt. The wet belt drives the oil pump pulley connected to the oil pump via a driveshaft that passes through the rear of the lower crankcase extension. The oil pump is not timed to the engine.

Lubrication System

The lubrication system incorporates a continuously variable oil pump. An oil control valve controls the oil pressure inside the mechanical oil pump. The ECM controls the commanded state of the valve based on the following inputs:

- engine speed
- calculated engine oil temperature
- engine oil pressure
- engine run time

When the control module commands the valve OFF, oil pressure increases. When the solenoid valve is commanded ON, oil pressure decreases.

Oil is pulled from the oil pump suction pipe to the oil pump. The oil pump flow control valve, controlled by the ECM, is mounted to the oil pump and provides two-stage functionality.

The oil is then applied under pressure through the oil cooler to the oil filter, where contaminants are removed. The engine oil pressure sensor and engine oil temperature sensor are located on the lower crankcase extension. These sensors provide the engine oil pressure and temperature data to the ECM.

The clean oil flows from the oil filter in different passages. One passage flows to the primary timing chain tensioner.

Oil Pan

The oil pan is made of stamped aluminum. The oil pan is attached at the engine block lower crankcase extension.

Oil Heat Exchanger

The engine oil heater exchanger is attached to the left side of the engine and exchanges heat between the engine oil and engine coolant.

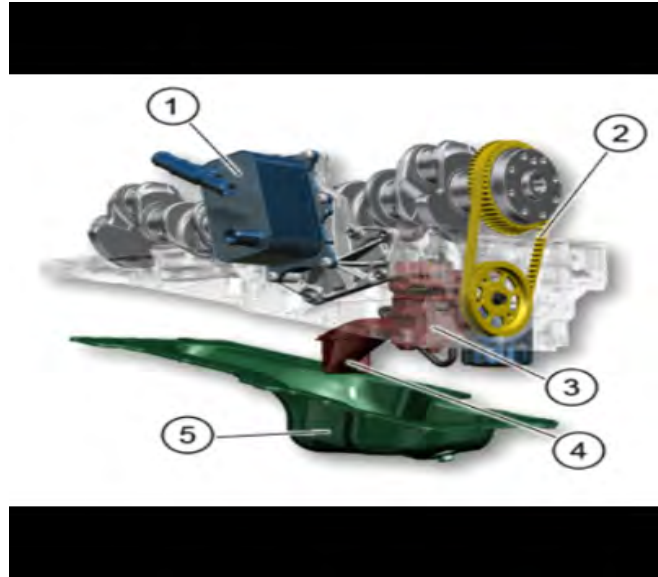

5619532

1. Oil Heat Exchanger
2. Oil Pump Drive Belt
3. Oil Pump
4. Oil Pick Up Tube
5. Oil Pan

Oil Pan

Air Intake System

Intake Manifold:

The intake manifold directs airflow to the cylinder head combustion chamber. The intake manifold incorporates an intake manifold runner control valve to create a swirl in the combustion chamber to get a homogeneous diesel air mixture.

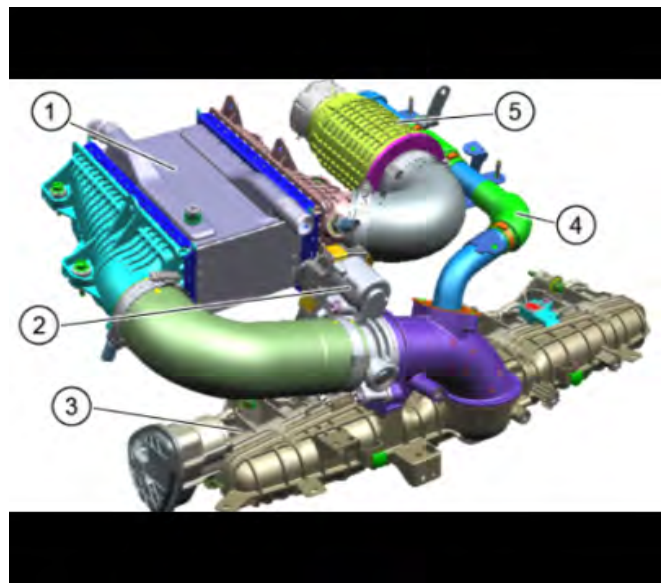

5619533

1. Water Cooled Charge Air Cooler
2. Intake Air Flow Valve
3. Intake Manifold
4. EGR Pipe
5. Resonator

Intake Air System

Resonator

The resonator reduces the pressure sound waves in the intake system, resulting in a quieter operating engine.

Intake Air Flow Valve

The intake airflow valve is a throttle plate that aids in achieving high exhaust gas recirculation rates. The flow valve increases the pressure difference between exhaust and intake so the appropriate exhaust quantity can be mixed with the intake air.

The ECM controls the intake airflow valve using dedicated circuits to provide power and ground to the motor. Switching the polarity reverses the direction of travel. The intake airflow valve contains a throttle position sensor that monitors the position of the valve and translates the reading to a digital signal that is transmitted to the ECM.

The throttle position sensor is mounted within the valve assembly and is not serviceable. The throttle position sensor provides a variable voltage signal, which is relative to the throttle blade angle. The ECM decodes the serial data signal into separate voltage values; the scan tool displays the position voltage parameters as throttle position sensors 1 and 2.

Exhaust Gas Recirculation System

The 3.0L (LM2) diesel engine has a low and high pressure EGR system. The low pressure EGR loop recirculates the exhaust gas into a gas-to-liquid heat exchanger to cool before being passed through the turbocharger and the charge air cooler. This results in a lower overall charge air temperature when compared to a similar amount of EGR being added through a high

pressure EGR loop. A low pressure EGR is used at high loads and as an additional control to increase low pressure EGR flow at part load operation.

To avoid condensation at the turbocharger compressor inlet, the low pressure EGR valve is closed when coolant temperatures are below 60°C (140°F) and during the exhaust aftertreatment warm up phase. In both conditions, only the high pressure EGR is functional.

The high pressure EGR valve is water-cooled and is mainly used under low-load conditions where there is a lack of pressure in the low pressure loop to drive EGR flow.

The exhaust throttle valve controls exhaust gas flow for the low pressure EGR system. The valve is water-cooled to protect the component's circuitry from high exhaust temperatures.

Exhaust Aftertreatment System

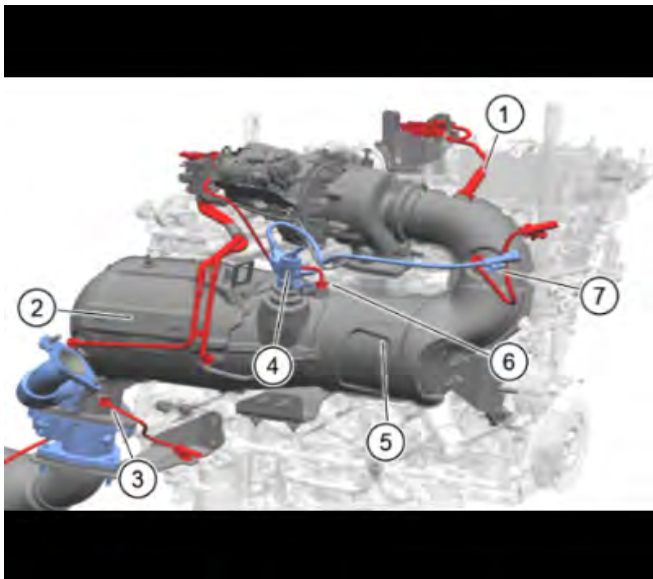

5619534

1. NOx Sensor 1
2. Selective Catalyst Reduction and Diesel Particulate Filter
3. Exhaust Gas Temperature Sensor 3
4. Diesel Exhaust Fluid (DEF) Injector
5. Diesel Oxidation Catalyst
6. Exhaust Gas Temperature Sensor 2
7. Exhaust Gas Temperature Sensor 1

The 3.0L (LM2) diesel engine aftertreatment system functions the same as other GM diesel engines, though it is packaged differently. The diesel oxidation catalyst is in the front, while the selective catalyst reduction filter is toward the rear of this component. The selective catalyst reduction also includes the diesel particulate filter.

NOx Sensors

The selective catalytic reduction aftertreatment system has three NOx sensors that monitor the function of the selective catalytic reduction system. The ECM uses the NOx sensor information to provide closed-loop control

of the reductant injector. The sensors have integrated circuits that manage the sensor heater, relay sensor signals, and diagnostic information to the ECM. NOx Sensor 1 is located after the turbocharger. NOx Sensor 2 is located before the rear selective catalyst, and NOx Sensor 3 is located after the selective catalyst.

Selective Catalyst Reduction and Diesel Particulate Filter

When DEF is injected into the hot exhaust stream, the heat in the exhaust decomposes the DEF into ammonia. The NOx and ammonia enter the selective catalytic reduction and are converted to nitrogen, carbon dioxide (CO₂), and water vapor through the catalytic reaction substrate.

The diesel particulate filter captures exhaust gas particulates, preventing their release into the atmosphere. Particulate-laden exhaust flows through the filter substrate, which consists of thousands of porous cells. Half of the cells are open at the filter inlet but are capped at the filter outlet. The other half of the cells are capped at the filter inlet and open at the filter outlet. This forces the particulate-laden exhaust gases through the porous walls of the inlet cells into the adjacent outlet cells, trapping the particulate matter.

Over time, the soot trapped on the cell walls restricts exhaust flow through the particulate filter, reducing its effectiveness as well as reducing engine efficiency. Once soot buildup reaches a specified limit, as signaled by the increased pressure drop across the filter, the ECM commands a regeneration event to burn-off the collected soot. Regeneration events occur automatically and without driver knowledge during vehicle operation. In general, the vehicle needs to be operating continuously at speeds above 48 km/h (30 MPH) for approximately 20–30 minutes for a full and effective regeneration to complete.

Differential Pressure Sensor

Restrictions in exhaust flow produce a pressure drop across the particulate filter. As the cell walls become saturated with trapped soot, the pressure drop becomes greater. A differential pressure sensor monitors the pressure drop across the filter and provides the ECM with a voltage signal proportional to soot buildup.

Diesel Exhaust Fluid Injector

The DEF injector is located between the diesel oxidation catalyst and the selective catalytic reduction/diesel particulate filter. A PWM signal controls this injector. NOx concentrations, based on the NOx sensors, determine DEF dosing into the exhaust stream. The correct amount of DEF dosing is important to proper operation.

Diesel Exhaust Fluid Under-Dosing

Under-dosing, caused by an insufficient amount of DEF being injected, will not allow the selective catalytic reduction to reduce NOx emissions properly. This causes high levels of NOx to enter the atmosphere, usually causing DTCs to set in the ECM.

Diesel Exhaust Fluid Over-Dosing

Over-dosing is caused by an excessive amount of DEF being injected. Over-dosing saturates the selective catalyst reduction, cools down exhaust temperatures, and creates a condition known as ammonia slip, where a high level of ammonia exits the selective catalyst reduction. The NOx sensor cannot differentiate between NOx and ammonia. Ammonia slip causes the NOx sensor after the selective catalyst reduction to detect higher levels of NOx than what actually exist. Conditions that may cause over-dosing include a stuck-open dosing injector, malfunctioning NOx sensors, or an electrical concern.

Exhaust Gas Temperature Sensors

There are three exhaust gas temperature sensors located in the front, middle, and rear of the assembly. The ECM monitors the exhaust gas temperature sensors to ensure the exhaust gas temperatures upstream and downstream of the exhaust system components are within a calibrated range so that maximum NOx conversion occurs.

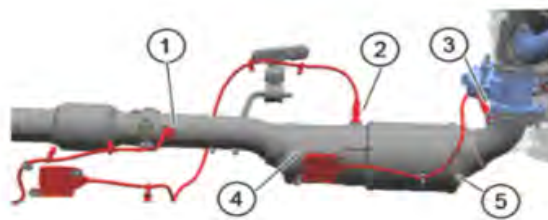

5619535

1. Particulate Matter Sensor
2. NOx Sensor 3
3. NOx Sensor 2
4. Rear Oxidation Catalyst
5. Selective Catalyst Reduction

Exhaust Gas Temperature Sensors

6.2L (L87) V8 Engine

The 2021 Cadillac Escalade is available with the Gen 5 V8 engine. The engine is equipped with Active Fuel Management™ systems. The 6.2L (L87) V8 engine is essentially the same as the 5.3L (L84) V8 engine with more cylinder displacement.

6.2L (L87) V8 Engine Specifications

- **Engine Type:** V8 VVT DI with AFM
- **Displacement:** 6.2L (376 CID)
- **Bore x Stroke:** 103.25 mm x 92 mm (4.06 in x 3.62 in)

- **Block Material:** Cast Aluminum
- **Cylinder Head Material:** Cast Aluminum
- **Compression Ratio:** 11.5:1
- **Firing Order:** 1-8-7-2-6-5-4-3
- **Horsepower (@5000 RPM)** 313 kW (420 HP)
- **Torque (@4000 RPM)** 527 Nm (460 lb ft)

Mechanical Features

The 6.2L (L87) V8 engine has the following mechanical features:

- cast aluminum pistons
- powdered metal connecting rods
- one-piece cast aluminum oil pan with a rear-sump design
- hardened forged steel crankshaft
- dual-stage oil pump

Engine Control Systems

The 6.2L (L87) V8 engine has the following engine control systems:

- direct fuel injection
- coil near plug ignition
- variable valve timing
- throttle actuator control system
- new dynamic fuel management systems

Dynamic Fuel Management

Dynamic fuel management is an Active Fuel Management™ technology that can deactivate any combination of cylinder valves of an internal combustion engine. This technology combines millisecond-accurate torque control with cylinder deactivation to optimize fuel consumption. The control of every cylinder event optimizes engine operation for peak efficiency throughout the range of engine operation. Because any cylinder can be deactivated, a large variety of firing sequences are possible, including rotating cylinder deactivation patterns and fixed patterns. For rotating patterns, the cylinders being deactivated can change with each subsequent engine cycle. Transitions between firing sequences is accomplished in a continuous fashion, making the transitions seamless and transparent to the vehicle operator.

Valve Lifter Oil Solenoid Valve Location

The cylinder deactivation system uses electrically operated electro-hydraulic actuator devices called the valve lifter oil solenoid valves. The valve lifter oil solenoid valves are bolted at each cylinder in the engine block valley, below the intake manifold assembly.

Dynamic Valve Lifter Oil Solenoid Valve Assembly Mounted in the Engine Block Valley

Valve Lifter Oil Solenoid Valve Operation

The valve lifter oil solenoid valves are energized with peak-hold current drivers for faster response with lower variation. Each solenoid controls the application of engine oil pressure to the intake and exhaust valve lifters on the cylinders selected to deactivate. Engine oil pressure is routed to internal oil passages on the cylinder block.

When all enabling conditions are met for cylinder deactivation, the ECM allows current to flow through the solenoid windings. With the coil windings energized, the solenoid valve opens, redirecting engine oil pressure through the valve lifter oil solenoid valves into separate vertical passages in the engine lifter valley. Each cylinder has two vertical passages connected to the valve lifter bores. When vehicle operating conditions require cylinder activation, the ECM turns off the control circuits for the solenoids, allowing the solenoid valves to close. With the solenoid valves closed, engine oil pressure in the control ports is exhausted. Air trapped in the system is purged by turning the solenoid on periodically with very short purge pulses.

Dynamic Fuel Management Solenoid Remover Tool

The dynamic fuel management solenoid requires a tool to remove the valve lifter oil solenoid valves. This magnetic tool helps gain leverage to remove the valve lifter oil solenoids from the block. Once installed on top of the solenoid, place your hand over the remover and solenoid with a finger under the solenoid. Twist while pulling up on the tool and the solenoid.



5619536

For diagnosis, no special tools are needed other than GDS2. Parameters and special functions can be used to review data and actuate the valve lifter oil solenoid valves.

Stop/Start System

The stop/start system on all Escalade engines improves fuel efficiency in stop/start driving. The vehicle automatically shuts down the engine in appropriate conditions, such as when stopped at a traffic light.



5619537

The tachometer needle points to AUTO STOP when the engine is shut down by the stop/start system. When the engine restarts, the tachometer resumes normal operation.

As soon as the brake pedal releases and/or the accelerator is pressed, the engine will start. The system takes approximately 0.3 seconds to start the engine.

To support the increased number of engine starts, a high performance electric starter motor with a stronger pinion engagement mechanism to reduce noise levels replaces the starter motor.

Along with the upgraded starter motor, advanced battery technology is required to ensure the vehicle's battery can handle the frequent charge and discharge cycles common with stop/start operation.

There is a battery sensor module connected to the battery, which continually monitors the battery charge and health state. The ECM uses this information from the battery sensor module to determine if the battery charge and health are sufficient for a stop/start condition.

Diagnostic Aids

When using a vehicle hoist to verify stop/start system operation, the following conditions must be met:

- transmission gear selector is in the DRIVE position
- no DTCs are set
- traction control is off

Start/Stop System Components

The following is a list of the system components in the stop/start system.

Engine Control Module

The ECM monitors the inputs from the Engine Coolant Temperature (ECT) sensor, Vehicle Speed Sensor (VSS), battery sensor module, hood ajar switch, brake booster vacuum sensor, and engine speed to determine autostart and autostop conditions. The ECM also controls the auxiliary coolant pump motor (if equipped).

Transmission Control Module

The Transmission Control Module (TCM) monitors the inputs from the transmission neutral safety switch to determine the driver-selected gear. This information is transmitted to the ECM via serial data to support the auto stop/start algorithm.

Engine Coolant Temperature Sensor

The ECT sensor is used to determine engine operating temperature.

Intake Air Temperature Sensor

The ECM uses the Intake Air Temperature (IAT) sensor to monitor ambient air temperature. If the temperature is too cold, the autostop will not occur.

Inside Air Temperature Sensor

The HVAC control module monitors the passenger compartment temperature sensor to determine the temperature inside the passenger compartment. The HVAC control module sends this temperature reading to the ECM on the data communication circuit. The ECM uses this temperature value to determine if a restart is required based on the temperature inside the passenger compartment.

Vehicle Speed Sensor

The VSS is used to determine vehicle speed. If vehicle speed is detected above a calculated value during an autostop condition, the ECM will start the engine.

Hood Ajar Switch

If the hood switch is in the open position, the vehicle will not autostop. If the hood is opened during an autostop, the vehicle will automatically restart.

Brake Booster Vacuum Sensor

The ECM monitors vacuum in order to ensure proper power assist for the brake pedal. If the ECM determines vacuum is too low, it will restart the engine.

Brake Pedal Position Sensor and Accelerator Pedal Position Sensor

The ECM monitors both the Brake Pedal Position (BPP) sensor and the Accelerator Pedal Position (APP) sensor to determine the level of activation for each. If the accelerator pedal is in the at-rest position with no pressure applied by the operator, a partially depressed brake pedal will cause the ECM to prepare the engine for an autostop event. When the vehicle is in an autostop event, if the status of the BPP sensor changes from meeting the autostop criteria to not meeting the criteria, the engine will be restarted provided all other autostart conditions are met. If the accelerator pedal is moved from the at-rest position, the vehicle will also enter an autostart event if all other conditions to support an autostart event, except for the brake pedal position, are met.

Transmission Gear Shift Position Switch

The transmission gear shift position switch is used to determine if the transmission is in the proper state to allow an autostop/autostart event. The ECM will not allow autostop until the brake is engaged, the transmission is in the forward gear position, and the vehicle slows to below the minimum speed required to allow an autostop, while meeting all of the other minimum criteria to support an autostop event.

Coolant Pump Motor

The ECM turns on the auxiliary coolant pump motor during autostop to maintain engine operating temperature and HVAC temperature. Once the engine is running, the ECM turns off the coolant pump motor.

Body Control Module

The BCM monitors the Autostop Disable switch in order to enable or disable the system. It sends the appropriate messages to the ECM via serial data to enable or disable the system.

Battery Sensor Module

The battery sensor module monitors the battery current load, state of health, and state of charge; the information is sent to the BCM via Local Area Network (LIN) and then to the ECM via serial data. If the module detects high current load, or the battery is in a poor state of health or a low charge condition, the ECM will not allow Autostop to occur.

Autostop Disable Switch

The disable switch is an input to the BCM and allows the customer to disable or re-enable the autostop system. After the vehicle is turned off, the autostop system turns back on the next time the vehicle is started.



5619538

The non-latching disable switch is located to the left of the steering column and above the headlamp switch.

Power Supply Transformer

The DC to DC converter monitors battery voltage and will maintain operating voltage to the radio, instrument cluster, and instrument panel displays. The DC to DC converter will provide a boosted voltage to sensitive loads during autostart to ensure proper operation of the driver informational displays.

Instrument Cluster

In order to differentiate between a normal engine shutdown (engine speed 0 RPM) and when the engine has been shut down by the stop/start system, the tachometer needle will rest at the Autostop indicator icon (500 RPM point) indicating the engine has been

shut down by the Stop/Start System. Once the engine is restarted, or the ECO button has disengaged autostop, the tachometer will function normally.

Dual Exhaust System



5619539

For better engine breathing, a dual exhaust system is standard with the 6.2L (L87) V8 engine. The dual exhaust system is not available with the 3.0L (LM2) I6 engine.

Driveline/Axle

Overview

The 2021 Cadillac Escalade driveline uses a Rear-Wheel Drive (RWD) configuration with a longitudinally mounted engine and transmission. In Four-Wheel Drive (4WD) vehicles, a transfer case directs power to the front and rear axles, or the rear axle only, depending on driver selection. Two-Wheel Drive (2WD) vehicles do not use a transfer case. In 2WD vehicles, power transfers directly from the transmission to the rear axle to propel the vehicle.

Transfer Cases

Transfer cases are found on 4WD vehicles and are responsible for dividing the power to all four wheels.

2-Speed Automatic Transfer Case



5619540

The 3025 (NQH) transfer case is a 2-speed, automatic, active transfer case. A 5-mode shift control switch (shown circled above) is located on the instrument panel. When the ignition key is in the RUN position, the transfer case shift control module monitors the transfer case shift control switch to determine if the driver desires a new mode/range position. The transfer case is electronically controlled for a seamless select though all modes. The driver can select AUTO 4WD position and four manual mode/range positions.

- AUTO range
- 4HI – 4-wheel drive high range
- 2HI – 2-wheel drive high range
- 4LO – 4-wheel drive low range, 2.72:1 gear ratio reduction
- NEUTRAL

4LO

The driver may choose to select any of these mode/range positions while driving the vehicle. However, the transfer case will not allow a shift into or out of 4LO unless the following criteria have been met:

- The ignition switch is in RUN
- The automatic transmission is in NEUTRAL
- The vehicle speed is below 5 km/h (3 mph).

NEUTRAL

1. Start the vehicle or turn the ignition to RUN
2. Shift the transmission to N (NEUTRAL).
3. Shift the transfer case to 2HI (shifts to transfer case NEUTRAL are only allowed when transfer case initial state is 2HI).
4. Apply the parking brake and/or service brake (if the parking brake and/or service brake is not applied within 20 seconds, the transfer case will remain in its original state).
5. Press 2HI five times in 10 seconds until the transfer case N indicator starts blinking in the cluster. When the shift to N is complete, the indicator in the cluster illuminates steady.

AUTO 4WD

AUTO 4WD is a full-time system that lets the vehicle operate in 2WD (either front or rear) until the system judges that 4WD is needed. AUTO 4WD provides the benefits of an on-demand torque biasing wet clutch and easy vehicle tuning through software calibrations.

In AUTO 4WD mode, the transfer case shift control module monitors rear wheel slip speed based on the inputs from the wheel speed sensors and/or the vehicle speed sensor. When the vehicle experiences a rear wheel slip condition, the transfer case shift control module sends a Pulse Width Modulated (PWM) signal to the transfer case two/four-wheel drive actuator. The two/four-wheel drive actuator rotates the transfer case control actuator shaft, applying a clutch. The clutch is designed to deliver a variable amount of torque. The clutch normally delivers torque to the rear wheels and transfers it to the front wheels. Torque is ramped up to the front wheels until the front wheel speed sensors match that of the rear wheel speed sensors and/or the vehicle speed sensor. Torque is then ramped down to the front wheels. The process repeats if rear wheel slip is detected again.

1-Speed Automatic Transfer Case

The 3015 (NPO) transfer case is a 1-speed automatic, active transfer case that provides three modes: Auto 4WD, 4HI, and 2HI.

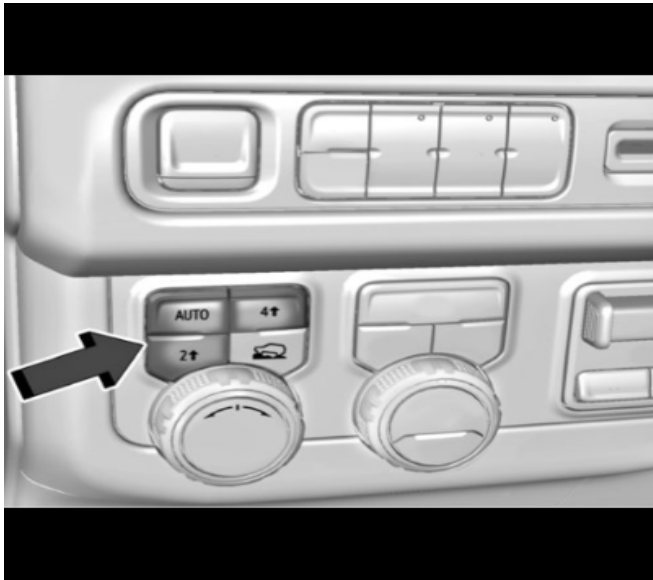

5619541

Shifts between any driving mode may be made at normal driving speed.

Front Drive and Rear Drive Axles

The 2021 Cadillac Escalade has two new rear axles. The solid rear axle has been replaced with a rear drive module to allow for the G86 limited slip rear axle and the electronic G96 positraction limited slip axle. This supports the independent rear suspension. The front axle remains unchanged.

Front Axle Description and Operation

The front axle on selectable 4WD vehicles uses a central disconnect feature in order to engage and disengage the front axle. When the driver engages the 4WD system, the transfer case control module sends a signal to the electric motor actuator to energize and extend the plunger inside. The extended plunger moves the clutch fork and clutch fork sleeve across the inner axle shaft and the clutch fork shaft, and it locks the two shafts together. The locking of the two shafts allows the axle to operate in the same manner as a semi-floating rear axle. A propeller shaft connects the transfer case to the front axle.

The differential carrier assembly uses a conventional ring and pinion gear set to transmit the driving force of the engine to the wheels. The open differential allows the wheels to turn at different rates of speed while the axle continues to transmit the driving force. This prevents tire scuffing when going around corners and premature wear on internal axle parts. The ring and pinion set and the differential are contained within the carrier.

The axle identification number is located on top of the differential housing assembly or on a label on the bottom of the right half of differential carrier assembly. The wheel drive shafts are flexible assemblies. Inner and outer constant velocity joints are protected by thermoplastic boots and connected by a front wheel driveshaft.

Limited Slip Rear Differentials

Standard G86 Limited Slip Rear Differential

The limited rear differential is a mechanical standard differential that provides excellent traction with seamless engagement and disengagement locking. The G86 limited slip rear differential consists of the following components:

- differential case
- pinion gear shaft
- differential pinion gear shaft lock bolt
- two clutch discs sets
- locking differential side gears
- thrust block
- locking differential clutch disc guides
- differential side gear shim
- locking differential clutch disc thrust washer
- locking differential governor
- latching bracket
- cam plate assembly
- differential pinion gears
- differential pinion gear thrust washers

Operation

The base G86 mechanical limited slip rear differential enhances the traction capability of the rear axle by combining the characteristics of a limited-slip differential and the ability of the axle shafts to lock together as required. The G86 provides traction without abrupt engagement/disengagement locking thump. The differential accomplishes this in two ways. First, a series of clutch plates at each side of the differential case limits the amount of slippage between each wheel. Second, a mechanical locking mechanism stops the rotation of the right differential side gear, in order to transfer the rotating torque of the wheel without traction to the wheel with traction. When the axle locks it drives both wheels. Each function occurs under different conditions.

Limited Slip Function

Under normal conditions, when the differential is not locked, a small amount of limited slip action occurs. The gear separating force developed in the right-hand clutch pack is primarily responsible for this.

The operation of the limited slip function of the unit can be explained when the vehicle makes a right-hand turn. Since the left wheel travels farther than the right wheel, it must rotate faster than the ring gear and differential case assembly. This results in the left axle and left-side gear rotating faster than the differential case. The faster rotation of the left-side gear causes the pinion gears to rotate on the pinion shaft. This causes the right-side gear to rotate slower than the differential case.

The side gear spreading force produced by the pinion gears compresses the clutch packs, primarily the right side. However, the friction between the tires and the road surface is sufficient to overcome the friction of the clutch packs. This prevents the side gears from being held to the differential case.

Locking Function

The locking action occurs through the use of the following component parts:

- a governor mechanism with two flyweights
- a latching bracket
- the left-side cam plate and cam side gear

When the wheel-to-wheel speed difference is 100 RPM or under 32 km/h (20 MPH), the flyweights of the governor will fling out and one of them will contact an edge of the latching bracket. This happens because the left cam side gear and cam plate are rotating at a speed different, either slower or faster, than that of the ring gear and differential case assembly. The cam plate has teeth on its outer diameter surface in mesh with teeth on the shaft of the governor.

As the side gear rotates at a speed different than that of the differential case, the shaft of the governor rotates with enough speed to force the flyweights outward against spring tension. One of the flyweights catches its edge on the closest edge of the latching bracket, which is stationary in the differential case.

The latching process triggers a chain of events:

1. When the governor latches, it stops rotating. A small friction clutch inside the governor allows rotation, with resistance, of the governor shaft while one flyweight is held to the differential case through the latching bracket. The purpose of the governor's latching action is to slow the rotation of the cam plate as compared to the cam side gear. This will cause the cam plate to move out of its detent position.
2. The cam plate normally is held in its detent position by a small wave spring and detent humps resting in matching notches of the cam side gear. At this point, the ramps of the cam plate ride up on the ramps of the cam side gear, and the cam plate compresses the left clutch pack with a self-energizing action.
3. As the left clutch pack is compressed, it pushes the cam plate and cam side gear slightly toward the right side of the differential case. This movement of the cam side gear pushes the thrust block, which compresses the right-hand side gear clutch pack.
4. At this point, the force of the self-energizing clutches and the side gear separating force combine to hold the side gears to the differential case in the locking stage.

Available G96 Electronic Limited Slip Rear Differential

An available G96 electronic locking rear differential enhances the traction capability of the rear axle by reacting instantaneously to a loss of traction.

The K164 differential control module's function is to control the electronic limited slip differential. The module receives a torque request through the CAN bus and applies torque to the rear differential. The K164 control module is located in the trunk compartment.

The differential system contains the following main components:

- M135 differential lock motor
- position sensor (internal to motor)
- temperature sensor (internal to motor)

The locking torque causes a multiplication of wheel torque, which can be used to improve traction and/or vehicle dynamics. The M135 differential lock motor actuates a multidisc friction clutch via a reduction gear set. The M135 differential lock motor is used to close and open the clutch. The module controls the differential lock motor and monitors the differential sensors via the high speed CAN bus.

Transmission

Overview

The 2021 Cadillac Escalade is equipped with the Hydra-Matic 10L80 (MQC) 10-speed automatic transmission.

Transmission Identification Information

Identification information for the 10-speed 10L80 (MQC) transmission is located at the rear of the transmission. The transmission identification code contains the information shown in the graphic below.

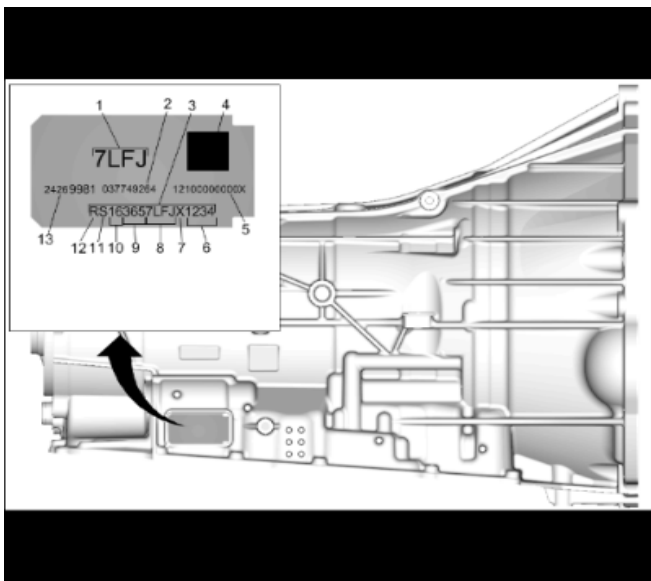

5619542

1. Broadcast Code
2. Source DUNS Number
3. Transmission Unique Number
4. 2D Machine Readable Matrix
5. VPPS Code
6. Part Sequence Number
7. Site ID
8. Broadcast Code
9. Julian Date
10. Year of Build
11. Shift ID
12. Line Plant ID
13. GM Part Number

10L80 (MQC) Automatic Transmission

The Hydra-Matic 10L80 (MQC) transmission is a heavy duty, fully automatic, 10-speed, electronically controlled transmission. This transmission features a push button Electronic Transmission Range Selector (ETRS) located on the instrument panel, as well as stop/start technology.

The transmission architecture features a case with integral bell housing for enhanced powertrain stiffness. A unique off-axis pump drive design allows for very low mounting in the transmission.

10L80 (MQC) Automatic Transmission Approximate Fluid Capacities:

- **Pan Removal and Filter Replacement – Approximate Capacity:** 7.7 liters (8.1 quarts)
- **Overhaul – Approximate Capacity (Transmission Volume Only):** 10.95 liters (11.57 quarts)
- **Complete Transmission System – Approximate Capacity (Including Cooler Volume):** 11.44 liters (12.08 quarts)

10L80 (MQC) Automatic Transmission Components

The 10L80 (MQC) automatic transmission includes the following key components:

Transmission Control Module

The TCM is externally mounted at the left front of the vehicle to the rear of the under hood fuse box. The controller makes use of four speed sensors. The TCM is part of a network of other control modules on the vehicle. The control modules share information with each other over a common serial data communications line. Based upon the TCM software/calibrations and input information, the TCM has final authority of when to allow an upshift or downshift whether in manual mode operation or in a drive position for automatic shifting.

Transmission Fluid Pump

The transmission fluid pump is a variable vane type, which is an off-axis gear-driven pump next to the valve body assembly. The pump maintains the hydraulic fluid pressures needed to apply the clutch pistons that apply or release the friction components

Torque Converter

The torque converter acts as a fluid coupling to smoothly transmit power from the engine to the transmission. It also hydraulically provides additional torque multiplication when required. The pressure plate, when applied, provides a mechanical direct drive coupling of the engine to the transmission.

The torque converter and electronically controlled capacity clutch reduce the possibility of noise, vibration, or chugge caused by Torque Converter Clutch (TCC) apply. In a torque converter with an electronically controlled capacity clutch, the pressure plate does not always fully lock to the torque converter cover. Instead, the pressure plate maintains a small amount of slippage. In Rear-Wheel Drive (RWD) 10-speed transmissions, this slippage can range from 0–50 RPM. Full lockup (0 RPM slip) is still available on some applications. The TCC may apply in 1st through 10th gear. The specific TCC apply points and the amount of clutch slippage are determined by a number of operating conditions, including throttle position, vehicle speed, and gear, as well as specific vehicle applications. Transmission fluid temperature also affects TCC apply points.

Friction Components

The friction components within the 10L80 (MQC) automatic transmission are the clutch assemblies.

Switches and Speed Sensors

The 10L80 MCQ transmission has the following switches and speed sensors:

- automatic transmission fluid temperature sensor
- automatic transmission input speed sensor
- automatic transmission intermediate speed sensor 1

- automatic transmission intermediate speed sensor 2
- automatic transmission output speed sensor 1

Planetary Gear Sets

The four planetary gear sets provide ten forward gear ratios and REVERSE. Changing gear ratios is fully automatic and is accomplished through the TCM. The TCM receives and monitors various electronic sensor inputs and uses this information to shift the transmission using output controls.

Valve Body Assembly

The valve body controls the flow of the hydraulic system. The 10-speed transmission could contain a maximum of nine individual solenoids — RPO dependent — installed in various bore locations on the lower control valve body assembly. Eight of the nine solenoid valves are used to control pressure regulation and direction of transmission fluid. The one ON/OFF solenoid valve is only used to direct transmission fluid.

The control solenoid valve body contains eight transmission pressure control solenoids and one direction control solenoid.

Electronic Transmission Range Selector



5619543

The ETRS system replaces the conventional gearshift on the 2021 Cadillac Escalade. The ETRS system is a shift-by-wire system. There is no physical link between the selector controls and the transmission. Electronic shifting and eliminating the shift cable helps eliminate noise and vibration from entering the vehicle. The push and pull buttons are backlit, rubber-coated, and located on the instrument panel.

The A97 Transmission Range Selector Controls in the ETRS system has no mechanical linkage to the transmission. Instead, the A97 Transmission Range Selector Controls will provide electrical signals based on customer input to the Engine Control Module, where the customer shift request will be determined.

The A97 Transmission Range Selector Controls Assembly includes:

- PARK Button — The PARK button has two internal contacts and a single push button. Its normally open switch is closed when the button is pressed. Actuation is one push.
- REVERSE Button — The REVERSE button has three internal contacts and a single pull button. Its normally open switch is closed when the button is pressed. Actuation is one pull.
- NEUTRAL Button — The NEUTRAL button has three internal contacts and a single push button. Its normally open switch is closed when the button is pressed. Actuation is one push.
- DRIVE Button — The DRIVE button has three internal contacts and a single pull button. Its normally open switch is closed when the button is pressed. Actuation is one pull.
- MANUAL/LOW Button — The MANUAL/LOW button has one internal contact and a single push button. Normally open switch that is closed when the button is pressed. Actuation is one push.

The vehicle is equipped with the following Electronic Transmission Range Selector Components:

- A97 Transmission Range Selector Controls
- K20 Engine Control Module
- K71 Transmission Control Module

ETRS uses the A97 Transmission Range Selector Controls to select each gear range. When the driver selects a specific range, the A97 Transmission Range Selector Controls provide an electrical signal (based on the driver's selection) to the K20 Engine Control Module. The K20 Engine Control Module sends a serial data signal to the K71 Transmission Control Module to shift the transmission into the selected range.

Latent Fault Mode

When the ETRS system detects a fault, the driver information center displays the message SERVICE TRANSMISSION NOW, UNABLE TO SHIFT SOON accompanied by a 10-second chime. The system forces the driver to acknowledge the message in order to show other data on the driver information center. The frequency of the message and chime increases until 50 trips have occurred with the fault present. At that point, an UNABLE TO SHIFT message will display and the transmission will not be allowed to shift out of PARK.

When the SERVICE SHIFTER SEE OWNER'S MANUAL message is shown on the driver information center, the shift lever requires service. If the vehicle is automatically shifting into P (PARK), check to see if the PARK button is stuck by running through the shifter electrical diagnostics. To operate the vehicle, hold the shift lever in the desired gear, R (REVERSE) or D (DRIVE), until the vehicle speed exceeds 15 km/h (10 MPH), and then release the shift lever.

Critical Fault Mode

When the ETRS system detects a fault and cannot determine either the requested or the actual gear position, the vehicle remains in the current commanded gear position until the vehicle speed is below 9 km/h (6 MPH). In order to lower vehicle speed, the Electronic

Brake Control Module (EBCM) sends a command to engage braking. When the vehicle speed falls below 8 km/h (5 MPH), the vehicle engages the electronic parking brake and backup parking lock (also known as Default to Park). The electronic parking brake will not disengage until the issue is corrected and all related Diagnostic Trouble Codes (DTCs) are cleared.

Neutral Service Mode

The neutral service mode allows the vehicle to remain in NEUTRAL for use in automatic car washes where the driver exits the vehicle. This mode is used when bringing the vehicle into the service bay area.

Manual Park Release

This vehicle is NOT equipped with a manual park release.

Service Considerations

Solenoid Characterization Reprogramming

Transmission control solenoid valves are pressure regulating valves. Each solenoid valve is tested after assembly to determine the output fluid pressure at certain electrical current values, applied to the coil windings. This information is referred to as solenoid current/pressure data points. The solenoid valves are tested two ways, with an increasing and decreasing electrical current applied to the coil windings. The resulting current versus pressure data points are saved and assigned a file number. The file number is marked on the solenoid valve housing end. The performance data file is stored on the TIS2Web site. This data file is programmed and stored in the vehicle's TCM. Replacing any of the following components will require the TCM to be programmed with the new or existing solenoid valve performance data.

- TCM: Program the new TCM with the existing solenoid data files stored on the TIS2Web site for all pressure regulating solenoid valves.
- Lower control valve body assembly with solenoid valves: Program the TCM with the new data files stored on the TIS2Web site for all pressure regulating solenoid valves.
- Transmission assembly: Program the TCM with the new data files stored on the TIS2Web site for all pressure regulating solenoid valves.

Transmission Fluid Level and Condition Check

This procedure checks both the transmission fluid level and the condition of the fluid itself. Since the transmission on this vehicle is not equipped with a fill tube and dipstick, a tube in the bottom pan is used to set the fluid level.

Note: This vehicle is equipped with an internal thermal bypass valve. The transmission fluid level should be checked only after the transmission fluid temperature has reached or exceeded an operating temperature of 70°C (158°F). Once the transmission fluid temperature has reached or exceeded 70°C (158°F), it is OK to check the fluid level.

Transmission Service Fast Learn Procedure

This procedure is required for any condition/repair related to shift quality or following a calibration update or software update. This procedure is required when the K71 transmission control module, T12 automatic transmission assembly or torque converter assembly have been repaired, replaced, removed, or serviced.

Note: Failure to perform this procedure may result in poor system performance, DTCs being set, or customer dissatisfaction.

The fast learn procedure performs a series of individual clutch applications, which allow the transmission control module to learn initial clutch apply pressures. The control module uses the learn values for clutch control and timing of shifts.

Heating, Ventilation, and Air Conditioning

Overview

The 2021 Cadillac Escalade features a dual-zone automatic climate control system to regulate temperature inside the passenger compartment. The Heating, Ventilation, and Air Conditioning (HVAC) system also transfers undesirable heat and moisture from inside the vehicle cabin to the outside air. The system contains a particulate and dust filter. In addition, vehicles equipped with the 3.0L (LM2) diesel engine use a reinforced electric heater to assist in warming the passenger compartment when the engine coolant has not sufficiently warmed to operating temperature.

Dual-Zone Automatic Climate Control

The dual-zone automatic climate control system with electronic controls allows the driver and front passenger to set separate desired interior temperatures.

AUTO mode for both the driver zone and the front passenger zone is enabled by pressing the AUTO control on the HVAC control panel or infotainment touch screen. Interior temperature for each zone may be manually set using the HVAC blower controls or the temperature control dials on the center stack. Temperatures between the driver and the front passenger zones may be synchronized using the SYNC control on the HVAC control panel or infotainment touch screen.

In AUTO mode, the HVAC control module maintains the comfort level inside of the vehicle by controlling the A/C compressor clutch, the blower motor, the air temperature actuators, mode actuator, and recirculation actuator.

To put the HVAC system in AUTO mode, the following are required:

- The auto switch must be activated.
- The air temperature switch must not be in either the full hot or full cold position.

Once the desired temperature is reached, the blower motor and the mode, recirculation, and temperature actuators automatically adjust to maintain the temperature selected.

When the warmest position is selected in automatic operation, the blower speed will increase gradually until the vehicle reaches normal operating temperature. When normal operating temperature is reached, the blower stays on high speed and the air temperature actuators stay in the full heat position.

When the coldest position is selected in automatic operation, the blower stays on high and the air temperature actuators stay in the full cold position. The mode actuator remains in the panel position and the recirculation actuator will remain in the recirculation position.

Under cold ambient temperatures, the automatic HVAC system provides heat in the most efficient manner. The operator can select an extreme temperature setting, but the system will not warm the vehicle any faster. Under warm ambient temperatures, the automatic HVAC system also provides air conditioning in the most efficient manner. Selecting an extreme cold temperature will not cool the vehicle faster.

The HVAC system may affect the operation of the stop/start system. The stop/start system will not shut the engine off at stops when the HVAC system has not reached the desired comfort level inside the vehicle. The system also prevents stop/start operation when in defogger mode to maintain the operation of the HVAC compressor.

Dual-Zone Automatic Climate Control System Components

The dual-zone automatic climate control system includes the following components:

HVAC Control Panel

The HVAC control display on the infotainment screen contains all switches, buttons, and dials that are required to control the functions of the HVAC system and serve as the interface between the operator and the HVAC control module. The selected values are passed to the HVAC control module via Local Interconnect Network (LIN) bus.



5619545

The HVAC control contains the switches required to control the functions of the HVAC system and serve as an interface between the operator and the Body Control Module (BCM). The selected values are communicated to the BCM via serial data.

Body Control Module

The BCM is a Controller Area Network (CAN) device that interfaces between the operator and the HVAC system to maintain and control the desired air temperature and air distribution settings. The BCM provides a device ON signal for the HVAC controls. The BCM provides blower, air delivery mode, and air temperature control.

Once the desired temperature is reached, the blower motor, mode, recirculation, and temperature actuators automatically adjust to maintain the temperature selected.

The BCM performs the following functions to maintain the desired air temperature:

- monitors these sensors:
 - ambient air temperature sensor
 - ambient light/sunload sensor
 - windshield temperature and inside moisture sensor
- regulates the blower motor speed
- positions the air temperature actuators
- positions the mode door actuator
- positions the recirculation actuator
- requests A/C operation
- controls the A/C compressor

The HVAC controls interface between the operator and the BCM to maintain and control the desired air temperature and air distribution settings. The battery positive (B+) voltage circuit provides power that the HVAC control module uses for keep alive memory. If the B+ voltage circuit loses power, all HVAC Diagnostic Trouble Codes (DTCs) and settings will be erased from keep alive memory. The BCM, which is the vehicle power mode master, provides a device ON signal. The HVAC control module provides blower, air delivery mode, and air temperature settings.

Air Distribution (First Row)

Blower Motor Assembly

To operate, the blower motor uses a fused B+, ground, control, and speed output signal circuits. The blower motor speed is controlled by increasing or decreasing the voltage drop on the ground side of the blower motor speed control circuit. The BCM provides a low side Pulse Width Modulation (PWM) signal to the blower motor to request a specific motor speed. The blower motor internal circuitry translates the PWM signal and drives the motor accordingly.

The blower motor has a signal wire used to output a speed signal. The signal is monitored by the BCM, and the value is sent to the ECM via serial data. The ECM monitors the blower motor speed to modify the total commanded engine coolant flow rate, which is a percentage of available coolant flow sent to the heater core for occupant comfort and windshield defrosting. When the HVAC blower speed is determined to be zero, the ECM disables the heater core coolant flow to optimize engine coolant flow for fuel economy and emissions.

Actuators

The HVAC case assembly uses doors to control air flow. The HVAC control module operates the doors through the use of actuators, with one actuator used for each door. The system has the following air control doors and associated actuators: mode, left temperature, right temperature, and recirculation. Each actuator used in the system is a 4-wire stepper motor. The BCM supplies a 12V reference voltage to the stepper motor and energizes the four stepper motor coils with a pulsed ground signal. The stepper motor moves the associated air control door into the calculated position in order to reach the selected position.

Actuator Recalibration

When installing a new actuator motor, the null point must be recalibrated. When the actuator is calibrated, the HVAC control module can drive the applicable coil to reach exactly the desired position of the door.

Evaporator Temperature Sensor

The evaporator temperature sensor is a 2-wire negative temperature coefficient thermistor and is located on the evaporator. The thermistor operates within a temperature range of -40 to $+85^{\circ}\text{C}$ (-40 to $+185^{\circ}\text{F}$). The sensor is installed at the evaporator and measures its temperature. Based on vehicle operating conditions and operator settings, the HVAC software algorithms determine a target evaporator air temperature. The operation of the variable-displacement compressor solenoid is adjusted as needed to quickly reach and maintain the targeted evaporator temperature.

Sunload, Temperature, and Ambient Light and Security Sensor

The sunload, temperature, ambient light, and security sensor includes a solar (sunload) sensor and passenger compartment temperature sensor. The sunload sensor is connected to a low reference and 5 V supplied by the BCM. As the sunload increases, the sensor signal voltage increases and vice versa. The signal provided to the BCM varies between 1.2–4.85 V.



5619546

The passenger compartment temperature sensor is a negative temperature coefficient thermistor, connected to a low reference and 5 V supplied by the BCM. As the interior air temperature increases, the sensor resistance decreases. The passenger compartment temperature sensor signal varies between 0–5 V.

Bright or high intensity light can cause the vehicle's interior temperature to increase. The HVAC system uses the sunload sensor values to compensate for the increased temperature and maintain the system HVAC settings.

Inside Air Moisture and Windshield Temperature Sensor

The windshield temperature and inside moisture sensor is located at the top center of the windshield. The relative humidity sensor, windshield temperature sensor, and humidity sensing element temperature sensor are all in one assembly.



5619547

This sensor assembly (location shown by the rectangle above) provides information about:

- relative humidity level at the windshield (passenger compartment side)
- temperature of the windshield (passenger compartment side)
- temperature of the humidity sensor element

The values for the humidity and temperature of the windshield are control inputs for the BCM application. The BCM calculates the fog risk on the windshield compartment side and can reduce fuel consumption by decreasing A/C compressor power to a minimum without causing any fog. The sensor will also enable partial recirculation mode in order to improve heat-up performance of the passenger compartment under cold ambient temperature conditions without the risk of mist build-up on the windshield. The humidity sensor element temperature sensor supplies the temperature of the humidity sensor element. It is only needed if the thermal contact between the humidity sensing element and the inside windshield surface is not sufficient.

The sensor is part of a LIN windshield sensor array, and the windshield temperature and humidity values are transmitted to the BCM via serial data.

Passenger Compartment Air Filter

The passenger compartment air filter removes dust and other irritants from the air before it enters the cabin. The filter is located behind the glove box door.

The recommended filter change interval is every 2 years or 36,000 km (22,500 mi). If there is a reduction in airflow or window fogging, inspect the filter. Vehicles driven in environments with poor air quality or high dust levels may require more frequent service.

Refrigerant System

The refrigerant system has unique refrigerant lines that contain an internal heat exchanger. The refrigerant system comes filled with R-1234yf refrigerant. The refrigerant system consists of the following components.

A/C Compressors

The A/C compressor is located at the front lower right of the engine. The compressor uses a conventional belt driven magnetic clutch to engage and mechanically turn on the compressor. When the A/C switch is pressed, the HVAC control module sends an A/C request message to the Engine Control Module (ECM) via serial data. If specific criteria are met, the ECM then grounds the A/C compressor clutch relay control circuit, which closes the A/C compressor clutch relay contacts. With the relay contacts closed, battery voltage is supplied to the permanently grounded A/C compressor clutch. The A/C compressor clutch then activates. This A/C system utilizes a variable-displacement solenoid valve to alter the amount of displacement created by the turning of the compressor. The HVAC control module provides both battery voltage and a PWM ground to the variable displacement solenoid valve. The performance of the A/C compressor is regulated based on cooling load.

Condenser and Receiver/Dehydrator

The condenser is made of aluminum tubing and aluminum cooling fins and is located in front of the radiator for maximum heat transfer. As the refrigerant flows through the condenser, the heat of the refrigerant is transferred to the ambient air passing through the condenser. Cooling the refrigerant causes the refrigerant to condense and change from a vapor to a liquid state. The semi-cooled liquid refrigerant exits the condenser and flows through the internal heat exchanger in the refrigerant line to the thermal expansion valve. The semi-cooled liquid refrigerant exits the condenser and flows through the receiver/dehydrator where any moisture in the system is absorbed. The receiver/dehydrator mounts directly to the condenser.

Refrigerant Lines and Internal Heat Exchanger

The refrigerant lines contain an internal heat exchanger designed into the refrigerant system to increase efficiency. The internal heat exchanger is a refrigerant line assembly where the liquid line from the condenser is routed around the vapor line. The heat exchanger line transfers heat energy from the liquid line to the vapor line by removing heat from the liquid line. The heat exchanger pre-cools the liquid refrigerant before reaching the expansion valve. The heat exchanger also increases cooling capacity.

Evaporator

As the refrigerant absorbs heat from the passenger compartment, the refrigerant vaporizes. Refrigerant vapor travels out of the evaporator, through the internal heat exchanger, and back to the compressor inlet. Then, the cycle begins again.

A/C Refrigerant Pressure Sensor

The A/C refrigerant pressure sensor is located on the high side line from the compressor to the condenser. The sensor is a 3-wire piezoelectric pressure transducer. A 5V reference voltage, low reference, and signal circuits enable the sensor to operate. The A/C pressure signal can be between 0.2–4.8 V. When the A/C refrigerant pressure is low, the signal value is near 0 V. When the A/C refrigerant pressure is high, the signal value is near 5 V. The ECM converts the voltage signal to a pressure value. When pressure is too high or too low, the ECM will not allow the A/C compressor clutch to engage.

Thermostatic Expansion Valve

The Thermostatic Expansion Valve (TXV) is connected to the evaporator core and regulates the flow of refrigerant into the evaporator. Both lines run through the TXV valve. The TXV is the dividing point for the high and low pressure sides of the A/C system. The pressure change causes some of the refrigerant to boil, reducing the temperature. The low temperature, low pressure refrigerant is directed to the evaporator.

Refrigerant Oil and Quantity Charts

Refrigerant oil is required to lubricate the internal moving components of the compressor. It is important to replace the same amount of oil removed during refrigerant recovery to ensure proper functioning of the compressor. Polyalkylene Glycol (PAG) oil must be used. The following is a list of the approximate refrigerant oil capacities:

- **Compressor Replacement:** 41 ml* (1.4 oz*)
- **Condenser Replacement:** 30 ml* (1.0 oz*)
- **Evaporator Replacement (Front):** 60 ml* (2.0 oz*)
- **Evaporator Replacement (Rear):** 60 ml* (2.0 oz*)
- **Total System Refrigerant Oil Capacity:** 195 ml (6.59 oz)

R-1234yf

- **Refrigerant Charge:** 0.82 kg (1.8 lb)

* If more than the specified amount of PAG oil was drained from a component, add the equal amount of oil drained.

Auxiliary Rear Heat and A/C System (C69)

The 2021 Cadillac Escalade is equipped with an auxiliary HVAC system. This system features a rear HVAC control unit, heater core, air conditioning evaporator, blower motor, and overhead air distribution vents. The HVAC case is located in the right rear corner of the vehicle wheel well and behind the trim panel. The HVAC auxiliary controls contain the switches, buttons, and dials required to control the functions of the rear HVAC system. Mode and temperature selections communicate with the A34 HVAC auxiliary controls via serial data. Rear blower motor speed is controlled via a signal circuit from the HVAC auxiliary controls to the auxiliary blower motor control module. The rear HVAC settings can be controlled by the front or the rear control units.

Rear Air Distribution

The desired rear air distribution mode can be selected with the mode switch at the auxiliary HVAC control. The auxiliary control communicates the values to the BCM via serial data. The BCM controls the auxiliary mode door actuator via the LIN bus to move the door to the calculated position. Depending on the position of the door, air is distributed through the headliner or lower panel ducts.

Auxiliary Blower Motor

The auxiliary blower motor regulates the air speed from the rear passenger ducts. The rear blower speed may be selected from the rear auxiliary HVAC controls.

Distribution Temperature Sensors

The air temperature sensors are 2-wire negative temperature co-efficient thermistors. The sensors operate within a temperature range of -40 to +85°C (-40 to +185°F). The sensors are installed in the headliner air distribution ducts and measure the temperature of the air that streams from the ducts. The HVAC auxiliary controls use these values to calculate the mixed air door position.

A signal circuit to each sensor and a common low reference circuit are provided by the A34 HVAC auxiliary controls.

Thermostatic Expansion Valve

The rear thermostatic expansion valve is connected to the rear auxiliary evaporator and regulates the flow of refrigerant through the rear evaporator.

Auxiliary Coolant Pump

The HVAC system includes an auxiliary coolant pump to circulate engine coolant through the heater core when the engine is off. The pump only runs when the cabin requires heat for comfort. The pump circulates coolant when the mechanical pump stops because the engine was turned off. The HVAC control module sends a serial data message to the ECM requesting pump operation. The ECM operates the pump by controlling the heater core coolant pump relay.

Electrical Auxiliary Heater and Defroster (C3A)

Some models are equipped with an electrical auxiliary heater and defroster to assist in warming the passenger compartment when the engine coolant has not sufficiently warmed to operating temperature. The heater is a 12V positive temperature coefficient heating element located in the HVAC case just downstream of the traditional heater core. The HVAC control module will activate it when the outside temperature is less than approximately 8°C (46°F), the engine coolant temperature is less than approximately 75°C (167°F), and the temperature blend door is commanded to the full hot position.

Body Systems

Overview

Depending on the region, the 2021 Cadillac Escalade may offer an all new power sliding console, a panoramic sunroof, and third row amenities, such as USB charging ports, 120/230 volt outlets, and cup holders, as well as more cargo area. Always refer to Service Information and the owner's manual for the most up-to-date information on features, configuration, use, and diagnostics.

Windows

Power Windows

The 2021 Cadillac Escalade offers the following window systems:

- express up/down driver and passenger windows
- express down left and right rear windows
- lockout switch feature

On vehicles equipped with an express up/down window system, a smart motor located in the driver and passenger doors is capable of detecting excessive resistance during the express up function. It automatically reverses direction if an occupant or other object is trapped between the window and the door frame while the window is closing. This detection of excessive resistance and automatic reversal of

direction acts as a safety feature to help prevent injury to vehicle occupants. Pulling and holding the widow switch overrides the automatic reverse feature.

A logic circuit located in the window motor monitors the requested state of the window switch. Operating the switch closes the contacts and causes the normally B+ voltage to drop on the appropriate signal circuit. The motor detects the voltage drop and performs the requested function.

Left and Right Rear Express Down Window Motors

The left and right rear doors also use smart motors. When the window switch is pressed in the down position, battery positive voltage is applied to the respective window motor control circuit and ground to the other window motor control circuit, causing that window to open. When the individual window switch is pulled in the up position, voltage and ground are applied to the window motor in the opposite direction, causing that window to close. The return path to ground is supplied through the inactive control circuit being normally grounded through the window switch.

All four windows operate with a serial data circuit allows the window switch and the Body Control Module (BCM) to communicate. Operating the switch sends a serial data signal to the BCM, allowing the driver to control the passenger windows. After receiving a signal from the driver switch, the BCM will send a control signal to the appropriate door, causing the window to move in the requested direction.

Window Normalization

A window motor that has not been normalized will no longer perform the express close and express open functions. This may occur when:

- a window motor has been disconnected
- a door harness has been disconnected
- the battery has been disconnected

Power Window Lockout Feature

The driver front side door window control switch contains a window lockout switch. When the driver presses the window lockout switch, a serial data message is sent to the BCM. The BCM then communicates a disable command to the rear side door window switches, deactivating them. The rear windows still function normally when using the switches on the driver front side door window control switch.

Seat Systems

The 2021 Cadillac Escalade is equipped with a driver and front passenger power seat system. Depending on the trim level, the power seats may be 8-way or 10-way on base models and 12-way on uplevel models. Some base models may have a passenger 6-way power seat. Uplevel models also may include heated/vented seats and memory features. Power seats include the following components.

- seat adjuster switch
- seat horizontal motor
- seat front vertical motor (if equipped)
- seat rear vertical motor
- seat recline motor
- seat memory control module (if equipped)

4-Way Lumbar/Massage Seats (AVK)

Some models have a front driver and passenger 4-way pneumatic lumbar support system. The power seat consists of the following components:

- seat lumbar support switch
- seat lumbar support control module
- seat lumbar/bolster pump

Lumbar Support Operation

When the lumbar support switch is in the forward direction, the control module activates the lumbar pump, inflating the upper and lower lumbar support bladders until the driver or passenger releases the switch.

When the lumbar support switch is in the rearward direction, the control module slowly deflates the upper and lower lumbar support bladders until the driver or passenger releases the switch.

When the lumbar support switch is in the up direction, the seat control module slowly inflates the upper lumbar support bladder until the driver or passenger releases the switch.

When the lumbar support switch is in the down direction, the control module slowly deflates the upper lumbar bladder and inflates the lower lumbar bladder. The seat lumbar support control module continues this operation until the driver or passenger releases the switch.

6-Way Power Seats (A7J)

Some standard models may have a front passenger 6-way power seat. The X53A fuse block 30A fuse located at the rear of the vehicle supplies power to the seat adjuster switch. The power seat consists of the following components:

- seat adjuster switch
- seat horizontal motor (fore and aft adjustment)
- seat rear vertical motor (height adjustment)
- seat recline motor

8-Way (A2X) and 10-Way Power Seats (AUN/A45)

The uplevel trims feature either an 8-way or a 10-way front power seat system, which consists of the following components:

- seat adjuster switch
- seat horizontal motor
- seat front vertical motor (if equipped)
- seat rear vertical motor
- seat recline motor

If equipped with memory seats, the following additional components are included:

- seat memory control module
- seat memory switch

Seat Motors

Seat switches provide both power and ground to the seat motors. Each seat motor is reversible and operates independently of the others. Each motor contains an electronic circuit breaker that opens in the event of a circuit overload and resets once voltage has been removed from the circuit.

There are four seat position motors and two lumbar motors. The motors include the horizontal motor, front vertical motor, rear vertical motor, and the seat back recline motor. The seat horizontal motor moves the entire seat forward and rearward. The seat vertical motors may operate independently to tilt the front or rear of the seat cushion up or down. Both motors can run simultaneously to move the entire seat up or down. The recline motor moves the angle of the seat back forward or rearward.

Heated/Vented Seat System

The heated/vented seat system consists of the following components:

- heated and vented seat switches
- BCM
- front seat heating control module
- driver seat cushion heating element
- driver seat cushion temperature sensor
- driver seat back heating element
- driver seat back temperature sensor
- driver seat temperature control module
- driver seat cushion blower motor
- driver seat back blower motor
- passenger seat cushion heating element
- passenger seat cushion temperature sensor
- passenger seat back heating element
- passenger seat back temperature sensor
- passenger seat temperature control module
- passenger seat cushion blower motor
- passenger seat back blower motor

Heated/Vented Seat Switches



5619549

The driver and passenger heated and vented seats are controlled by separate heated/vented seat switches (shown circled above). They are located on the center stack near the HVAC controls. To operate the switches, the engine must be running. The BCM monitors activation of the heated/vented seat switches. The

BCM also controls the indicators used to provide the operator with feedback as to the operating status of the system. With each press of the switch, the system cycles through HIGH, MEDIUM, LOW, and then back to OFF again.

Heated Seat Operation:

The seat heating control module controls heated seat operation for the driver and passenger seats. There are two modes for heated seat operation: seat back and cushion heat mode and seat back-only heat mode. When active, individual Pulse Width Modulated (PWM) voltage supply control circuits apply power to the seat cushion and back heater elements. The K29F Front Seat Heating Control Module switches each individual heater element to ground by a common low-side drive control circuit.

When the heaters are off, the front seat heater control module directs the heating element low-side outputs to a common circuit internal to the module, which is biased to approximately 3.5 volts. The seat heating control module uses the biased voltage in to test the high-side and low-side control circuits for a short to battery positive or ground before turning on the driver and passenger seat heating elements. During heated seat operation, the front seat heating control module interrupts control of the heating elements every 10 seconds for approximately 10 milliseconds to make this biased voltage check.

If the high-side output of the module is measured when both the seat cushion and seat back heater elements are disconnected, a digital multimeter will display a low current 12V bleed off voltage. This bleed off voltage does not have a meaningful diagnostic purpose. With the heater elements connected, only 3.5V biased voltage is seen from this circuit.

Temperature Regulation

The seat back and cushion temperature sensors, or thermistors, are packaged with the seat heating elements located just under the seat covers. The front seat heater control module supplies each temperature sensor with a 5V reference signal circuit and a low reference circuit. The module monitors the voltage from the signal circuit to determine the temperature of the seat.

The temperature sensor varies in resistance based on the temperature of the heating element that is causing the signal voltage to change. Once the module senses the seat reached the set temperature, it will then begin to regulate the current flow through the heater elements in order to maintain the desired seat temperature based on the feedback voltage from the sensor.

If the heated seats are on HIGH, the temperature level may automatically be lowered after approximately 30 min of operation.

Vented Seat Operation

Each vented seat consists of two blower motors: one in the seat back and one in the seat cushion. During vented seat operation, the vented seat blower motors move cabin air through channels in the foam pad and small holes in the seat covers, causing a cooling effect to the occupant.

Battery voltage is supplied to the blower motors by a 10-amp fuse located in the left instrument panel fuse block. Ground for each blower motor is provided through separate ground circuits and a common ground connection.

When the seat heater control module receives a ventilation seat command and supplies a low-side driver PWM signal through the blower motor control circuit to each seat cushion blower motor. The logic in the blower motors interprets the signal and responds by adjusting the blower speed as requested. When the blower motors are operating, the occupant of the seat feels cooler as the air passes through the seat cushions.

Rear Seats

Second Row Seats

The second row seats may be a manual bench, an optional power bench, or bucket seats with a power option (for uplevel trims).

The left and right second row folding seat systems each consist of the following components.

- folding seat switch
- folding seat motor

The folding second row seats are operated by the folding seat switches, located on the passenger side rear panel and on the trim panel in the rear cargo area. While in a de-energized state, the park enable relay supplies battery voltage at all times to the folding seat switches. At all times, a 20A fuse, located in the rear body fuse block, also supplies battery voltage to the folding seat motors. When a folding seat switch is pressed, the switch contacts and the control circuit battery apply voltage to the folding seat motor. The motor runs to move the seat back to the folded position.

Second Row Heated Seats

Depending on the trim level, the second row seating may be equipped with an optional rear heated seat system, with control switches located on the rear console.

The rear heated seat system consists of the following components:

- rear heated seat switches
- BCM
- rear seat heating control module
- left and right rear seat cushion heating elements
- left and right rear seat cushion temperature sensors (thermistors)

Rear Heated Seat Operation

The rear seat heating control module controls heated seat operation for the left and right rear seats. When active, power is applied to the seat cushion heater element through a PWM voltage supply control circuit. The heater element is switched to ground by the module through a low-side drive control circuit.

Rear Heated Seat Switches



5619550

When a heated seat switch on the rear center console is pressed, a Local Interconnect Network (LIN) bus serial data message is sent from the rear heated seat switches (shown circled above) to the BCM, indicating the rear heated seat command. The BCM serves as the heated seat system master and determines the requested operating mode. The BCM sends serial data messages to the rear seat heating control module, indicating the heated seat command. In response to this serial data message from the BCM, the rear seat heating control module turns on the appropriate seat heating elements. The BCM also controls the seat temperature and mode indicators via the LIN serial data line to provide the operator with feedback as to the operating status of the system.

Temperature Regulation

The seat cushion temperature sensor (thermistor) is packaged with the seat heating element located just under the seat cover. The rear seat heating control module supplies the temperature sensor with a 5V reference signal circuit and a low reference circuit. The module monitors the voltage from the signal circuit to determine the temperature of the seat.

The temperature sensor varies in resistance, based on the temperature of the heating element causing the signal voltage to change. Once the module senses the seat has reached the set temperature, it will then begin to regulate the current flow through the heater elements in order to maintain the desired seat temperature, based on the feedback voltage from the sensor.

If the heated seats are on HIGH, the temperature level may automatically be lowered after approximately 30 min of operation.

Third Row 40/60 Split-Folding Seats

The 2021 Escalade is equipped with a standard 40/60 split folding third row seat. The larger portion of the seat is located on the driver's side of the vehicle. The feature provides a larger cargo load area on the folded driver side seat and still maintains the provision for a rear-seating passenger on the passenger side. An optional power bench is available.

The left and right third row folding seat system each consist of the following components:

- folding seat control module – third row
- folding seat switch – D-pillar third row
- folding seat motor – seat back release third row
- folding seat motor – third row

Third Row Seats – Control Module

The folding seat control module controls both sides of the 60/40 split folding seat. The folding seat control module is in a low-power sleep state until it detects the activation of one of the folding seat switches. The module remains in its normal operating awake mode and returns to sleep mode when all outputs and inputs such as the switches are inactive for 30 seconds.

A 30A fuse, located in the rear body fuse block, supplies battery positive voltage at all times to the folding seat control module. The module uses this voltage for both logic power and to power the seat motors and seat back release motors. Each folding seat motor and release motor is controlled by a relay internal to the folding seat control module and through two control circuits to each motor. The control module checks to see if the control circuits are shorted to ground or voltage before enabling folding seat operation.

Third Row Folding Seat Switches

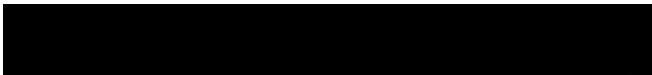

5619551

Note: The Right Rear Quarter Trim - Power Folding Rear Seat Switches are shown in the graphic above.

The third row folding seat switches are located on the D-pillar of the rear cargo area. Each side of the 60/40 split folding seat has a pair of fold and unfold, normally open, momentary switches designed to prevent simultaneous activation.

The folding power seats only operate when the transmission is in the PARK position. Battery voltage is supplied to the power folding seat switches through the normally closed contacts of the park enable relay, which is controlled by the BCM. When the transmission is placed in any gear other than PARK, the BCM energizes the relay, removing battery voltage from the switches.

Third Row Folding Seat Motor – Seat Back Release

The folding seat back release motor is spring-loaded and latches the seat back into its desired parked position, and unlatches the seat back for folding or unfolding seat operation. There are three modes of release motor control.

- retract
- hold
- release

Pressing the folding seat switch signals the seat control module to apply PWM voltage at approximately 95% duty cycle to the seat back release motor control circuit, releasing the seat back. The control module holds the release motor at a reduced voltage (approximately 25% duty cycle) until the motor stalls. Once the motor stalls, the module releases the motor, latching the seat back in place. One second after releasing, the seat motor moves in the opposite direction of travel to confirm the seat back is locked in a secure position. This action continues until a stall condition is detected. After the completion of the latch lock confirmation, the module releases tension.

Each switch contact is connected to an individual, discrete input of the folding seat control module that provides a pull down to ground on these signal circuits. When a folding seat switch is pressed, battery voltage is applied through the switch contacts and the signal circuit to the folding seat control module. The module commands the folding seat to move in response to the switch signal.

Third Row Folding Seat Sensor

The folding seat motor contains an internal seat sensor. The sensor is a two-wire Hall-effect type sensor used to determine the stall status of the folding seat motor and provide seat position information to the K169 Folding Seat Control Module – Third Row.

The folding seat control module supplies 10 volts to the folding seat motors. During folding seat motor operation, the sensor provides four pulses per revolution input to the control module to determine when the seat motor reaches a stalled condition. A stalled condition is when the seat back is fully folded, fully unfolded, or if an object prevents seat movement during seat operation. If the module does not detect a pulse from the sensor for 100 ms, the module stops the folding seat operation.

Power Door Locks

The 2021 Cadillac Escalade is equipped with power door locks. The power door locks are controlled by the BCM. The BCM provides a power door lock command to the door lock actuators within the door latches whenever it receives an input signal from one of the following sources.

- power door lock switches (located on the driver and passenger doors)
- keyless entry lock or unlock command
- passive keyless entry
- door lock cylinder switch unlock actuation
- delayed locking command
- automatic door lock command

The door locks also feature lockout prevention, which prevents the doors from locking if the transmitter is in the vehicle

The doors may be unlocked using the power door lock switches, the unlock button on the keyless entry transmitter, or by approaching the vehicle with the passive keyless entry transmitter and pressing the button on the door handle. Low frequency transmitting antennas are located in the front door handles. The liftgate sends a challenge to the key fob to determine if it is within the 1 meter range to allow the vehicle to unlock.

The doors may be manually unlocked from inside the vehicle by pulling on the inside door handle. The first pull of the handle unlocks the door, and the second pull of the door handle opens the door.

Note: The lighting control module monitors the voltage of the rear door lock switches.

Automatic Door Locks

The doors lock automatically when all doors are closed, the ignition is on, and the transmission range is moved out of PARK.

If a vehicle door is unlocked and then opened and closed, the doors lock when the brake pedal is released or the vehicle speed is greater than 13 km/h (8 MPH).

To automatically unlock the doors, set the transmission range to PARK.

Automatic door unlocking can be programmed in the vehicle personalization menu.

The vehicle personalization menu offers the following selections for the automatic door locks:

- **Auto Door Lock** – When this feature is turned on, all doors will automatically lock when the vehicle is shifted out of PARK or when the vehicle starts moving. Select OFF or ON.
- **Auto Door Unlock** – This setting allows selection of which doors will automatically unlock when the vehicle is shifted into PARK. Select OFF, ALL DOORS, or DRIVER DOOR.
- **Delayed Door Lock** – When enabled, the feature delays locking of all doors. To override the delay, press the power door lock switch on the door. Select OFF or ON.

Child Safety Locks

The 2021 Cadillac Escalade is equipped with child safety locks. When engaged, the rear door safety locks prevent passengers from opening the rear doors from within the vehicle. The safety lock is on the inside edge of the rear doors.



5619552

Note: The child safety lock is shown in locked position in the graphic above.

Rear Hands-Free Power Liftgate

The 2021 Cadillac Escalade features an optional hands-free power liftgate with a Cadillac logo light projection.

Hands-Free Operation

This system uses a motion sensor located under the right rear bumper fascia and an optional logo projector. Waving your foot under the sensor area near the projected logo signals the liftgate to open.

If equipped, the power liftgate switch, located on the overhead console, can be used to change the liftgate height settings. The vehicle must be in PARK.

The modes are:

- **MAX** – Opens to maximum height.
- **3/4** – Opens to a reduced height that can be set from 3/4 to fully open. This is used to prevent the liftgate from opening into overhead obstructions such as a garage door or roof-mounted cargo. The liftgate can be opened manually all the way
- **OFF** – Opens manually only.

To power open or close the liftgate, select MAX or 3/4 mode and then perform any of the following:

- Press the liftgate button on the remote key fob twice until the liftgate moves.
- Press the center button on the overhead console. The driver door must be unlocked or locked without the security armed.

- Press the touch pad on the underside of the liftgate handle after unlocking all doors. A locked vehicle can be opened if the remote is within 1 m (3 ft) of the touch pad.
- Press the button on the bottom edge of the liftgate next to the latch to close.
- Press any liftgate button, the touch pad, or the remote key while the liftgate is moving to stop it. Pressing any liftgate button or pressing the key fob button twice quickly on the remote key restarts the operation in the reverse direction. Pressing the touch pad on the liftgate handle will restart the motion but only in the opening direction.

Caution: Manually forcing the liftgate to open or close during a power cycle can damage the vehicle. Allow the power cycle to complete.

When stopping the gate at low heights, it may partially reopen.

The power liftgate may be temporarily disabled in extremely low temperatures or after repeated power cycling over a short period of time. If this occurs, the liftgate can still be operated manually. Select OFF on the liftgate switch.

If the vehicle is shifted out of PARK while the power function is in progress, the liftgate will continue to completion. If the vehicle is accelerated before the liftgate has completed moving, the liftgate may stop or reverse direction. Check for driver information center messages and make sure the liftgate is closed and latched before driving.

Note: The foot activated liftgate default setting is set to “On Open Only”, which does not allow the liftgate to close using foot activation. To change the setting, go into the personalization menu and select “On-Open and Close”. There is also an “Off” selection to turn the feature off.

Projected Logo

A vehicle brand logo is projected onto the ground for 1 minute near the rear bumper whenever either of the following conditions occurs:

- A remote keyless entry transmitter is detected within an area of approximately 2 m (6 ft) outside the liftgate.
- A successful hands-free operation has occurred. The logo serves as a target area for the operator’s foot to make a kicking motion above the projected logo. Once activated, the projected vehicle logo remains active for one minute.

The projection logo does not illuminate if any of the following conditions are present:

- The vehicle battery is low.
- The transmission is not in the PARK range.
- Hands-free liftgate operation is set to OFF in vehicle personalization.
- The power liftgate is turned off.
- The vehicle remains parked for 72 hours or more, with no remote keyless entry transmitter use or keyless access operation.

To re-enable operation, press any button on the remote keyless entry transmitter or open and close a vehicle door.

If the procedure has been performed correctly, the hands-free liftgate sensor control module will send a serial data message to the liftgate control module. The tail lamps will then flash to indicate that the command has been received, and the liftgate will power open or power close.

Keyless Entry Transmitter

The BCM may get a liftgate release command from the remote keyless entry module. When the liftgate button is pressed on the keyless entry transmitter, a liftgate release request is sent to the remote keyless entry module. The remote keyless entry module then sends a serial data message to the BCM, and the BCM sends a serial data message to the liftgate control module, commanding the release of the liftgate.

Interior Switch



5619555

The power liftgate control switch located in the overhead console is controllable from the driver’s seat of the vehicle. The liftgate control switch (shown circled above) contains a push-button style switch that opens and closes the liftgate, as well as a selector knob that allows the driver to select between opening the liftgate all the way, opening the liftgate 3/4 of the way, or deactivating the power liftgate switch.

Liftgate Programming/Calibration

Garage Height Calibration

If any liftgate component is replaced or repaired, it will be necessary to perform a liftgate relearn procedure.

Mirrors

The exterior rearview mirrors are larger for increased visibility and highly tuned for aerodynamics, reduced noise, and vibration. They are available with manual folding or power folding, depending on the trim level. There are also heated, light-sensitive, and power options, as in previous years.

Power Assist Steps (Running Boards)

Assist Step Controller System Components

The assist step controller system consists of the following components:

- S148L Assist Step Kick Switch – Left
- S148R Assist Step Kick Switch – Right
- M48L Running Board Step – Left
- M48R Running Board Step – Right
- K4 Assist Step Control Module

Automatic and Manual Operation

Each assist step has a bi-directional motor and a Hall-effect sensor to detect the step's position. The Hall-effect sensors are included in the motor assembly. The polarity on each motor is switched to reverse the direction of assist step travel.

In normal mode, the running boards operate automatically. When a door opens, a power extend operation will occur on the side of the vehicle where the door opened. When both doors close on a side of the vehicle, a power retract operation will occur on that same side. Door ajar status input is received by the assist step control module through the serial data line from the BCM. The assist step controller receives the gear position and vehicle speed inputs through the serial data line.

The running boards can be manually deployed by pressing the assist step switch while the transmission is in PARK or NEUTRAL. The assist steps retract with a second push of the assist step switch if the transmission is shifted out of PARK or NEUTRAL or if vehicle speed exceeds 8 km/h (5 MPH).

Pressing and holding down the assist step switch for four seconds deactivates the running boards. Pressing and holding the switch again for another four seconds activates the running boards.

Object Detection

Each assist step reverses direction of travel when an object is detected in the travel path. If an assist step is moving in the retract direction, the assist step moves to the full extend position if an object is detected. If a door on the same side as the extended assist step is opened and then closed, the assist step moves to the retract position. The assist steps stop and hold if an object is detected.

Service Considerations

If a door is ajar, the running boards may retract and extend as the vehicle speeds change from above or below 3 km/h (2 MPH). Verify proper operation of door ajar switches, and ensure all doors are properly closed and latched.

If the running boards are stuck in extended or retracted position, verify there is nothing that can prohibit normal operation, such as physical damage or a build-up of mud, snow, or ice on boards and mechanical linkages.

Learn Procedure

When the assist step controller is replaced or loses battery power, the assist step controller must learn the position of both assist steps. At least one door must be opened and closed on each side of the vehicle for both

assist steps to go to a learn procedure. Each assist step will extend and then retract after a door is opened and closed on that assist step's side of the vehicle. Each assist step will learn its own position with the learn procedure.

Shipping Mode Unlock Procedure

Power Assist Step – Folded

Vehicles equipped with the power running boards are shipped from the assembly plant in disabled mode. The running boards are in the retracted position during shipping. To enable the running boards for normal operation, perform the following steps:

1. Ignition ON with all doors closed.
2. Enable the running boards in the vehicle settings.
3. The driver information center should display "Running Boards Enabled".
4. Open and close a driver and passenger door to verify running boards extend and retract.

Note: The switch is integrated into the infotainment system. Refer to the owner manual for more information.

Power Sliding Console

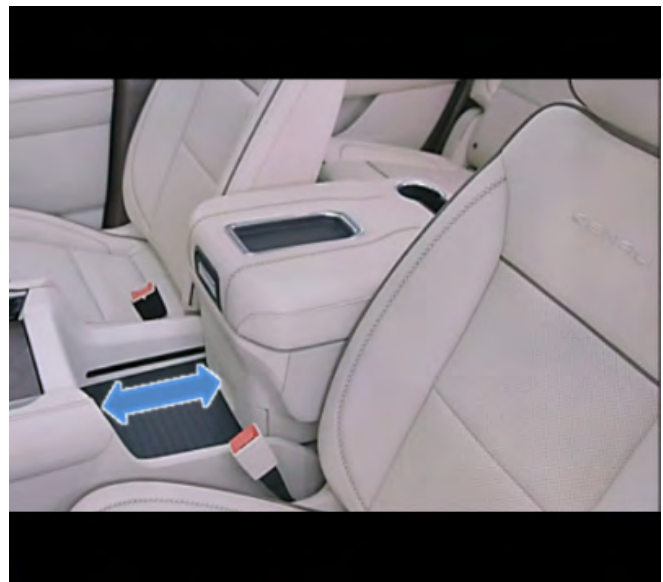

5619559

Power Sliding Center Console (Rear Position)

The 2021 Cadillac Escalade is available with an all new power sliding center console on uplevel trims. The power sliding center console operates by pressing and holding down the power sliding console switch located on the overhead console. Once the switch is pressed, the console slides rearward approximately 25.4 cm (10 inches).

When the vehicle is in valet mode, a drawer under the main console storage is inaccessible. The sliding console not only provides enhanced flexibility for storing and securing contents but also provides the second row seat passengers with easier access to the cup holders and rear console controls when the console is in the rearward position.

Cooler Box Operation

The cooler box is located in the power sliding center console. The cooler box uses a thermal electric device to cool. The cooled temperature will vary based on the ambient air temperature and the amount of contact to the surrounding box surface.

The ignition must be ON for the cooler box to operate. When the ignition is ON, a press of the momentary switch sends a request to activate the box to the center console compartment cooler control module.

When the cooler box is operating, the center console compartment cooler control module illuminates the indicator by providing ground. If the module detects a low voltage condition, the cooler box will not activate and the indicator flashes.

Headlamps

The standard LED headlamps improve driver visibility in low light conditions, at night, and in inclement weather.

The headlamps automatically turn the high-beam headlamps on when ambient light is low enough and no other traffic is present, at speeds above 40 km/h (25 MPH). It then turns the high beams off when ambient light conditions warrant or when it senses another vehicle may be affected by the high beams.

Each headlamp assembly contains an internal logic that monitors the components within the headlamp assembly. When a malfunction is detected, the K9 Body Control Module sets the appropriate DTC for the appropriate headlamp assembly.

IntelliBeam System

The IntelliBeam system uses the B174W Frontview windshield camera to monitor the approaching traffic headlights to determine if the high beams should be on or off to prevent a glaring condition from the vehicle's high beams. To enable the IntelliBeam system, use the multifunction switch on the steering column and alternate from low to high beams twice within two seconds, ensure the exterior lamp control is in AUTO position or the headlamps are ON.

Driver Information and Entertainment

Overview

Introducing the all-new Cadillac user experience in the 2021 Escalade. This state-of-the-art system features an exclusive three-screen OLED interface and premium technologies such as Augmented Reality, proximity sensing, one-touch pairing and much more. It is the most advanced Cadillac user experience to date.

Control Panel

Overview

Left of the steering wheel, a 7.2-inch diagonal touch-screen Control Panel allows you to view trip information, select the cluster layout and access Head-Up Display2 and Night Vision controls.

Trip Information



5660154

Displays Trip 1 and Trip 2 information, such as distance, on the touch-screen Control Panel. Press and hold the ROAD icon or anywhere on the screen to reset the information.

Cluster View Selection



5660155

Use this menu to select the content you want to display in the cluster:

- Gauge view (see CLUSTER DISPLAY for more information)
- Map view (see NAVIGATION for more information)
- Augmented Reality view (see NAVIGATION for more information)
- Night Vision view (if equipped)

Heads-Up Display Adjustment (If equipped)

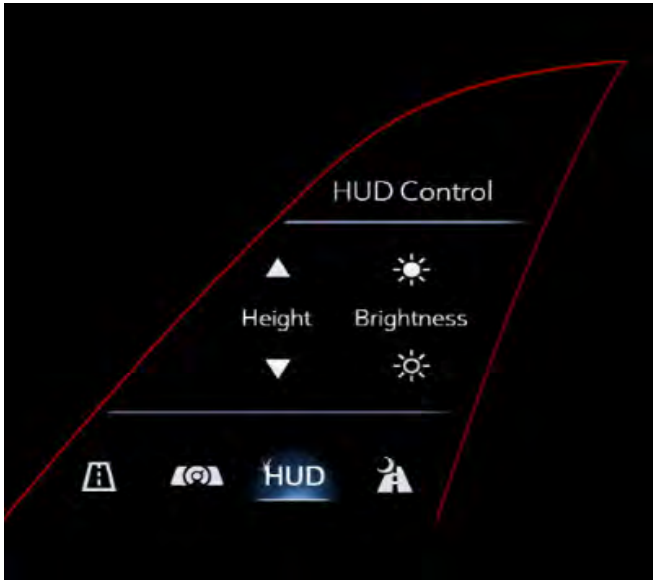

5660156

Once Head-Up Display is enabled, use this menu to control the brightness and vertical height of the Head-Up Display in the windshield.

Note: To turn Head-Up Display on or off, tap the SETTINGS app icon on the Infotainment Screen, then "Display," then "Head-Up Display"

Night Vision Display Adjustment (If equipped)



5660157

Use this menu to control the sharpness and brightness of the Night Vision display in the cluster.

Note: This icon will only appear when the Night Vision layout is selected.

Blank Screen

For a simplified appearance, when on the Trip Information page, you can swipe from right to left on the Control Panel to reach a blank screen. Swipe from right to left on the blank screen to return to the Control Panel menus. Tap the ROAD icon multiple times to cycle through pages.

Cluster Display

Overview

The 14.2-inch diagonal cluster display (nontouch) is fully customizable with multiple view options.

Cluster Layouts

Select a cluster layout using the Control Panel left of the steering wheel. Depending on your vehicle options, choose from:



5660161

- Gauge View



5660159

- Map View



5660158

- Augmented Reality View



5660160

- Night Vision View (if equipped)

Gauge View

When Gauge View is selected, you can customize the content shown in the left and right zones of the cluster. Here's how:

Left Zone (Vehicle Information)

Displays Vehicle Information and status details. To change this content, tap the VEHICLE INFORMATION app icon on the infotainment system, browse and select your desired content, then tap "Show in Cluster." To remove content from this zone, tap "Remove from Cluster."

Right Zone (Audio/Nav/Phone/Etc.)

Displays media content and notifications, including audio selections, phone information, route guidance and more. To change this content, use the controls on the right side of the steering wheel. Content may also

display here when you use the button switchbank located on the Instrument Panel left of the steering wheel.

Infotainment Screen

The 16.9-inch diagonal infotainment touch-screen features an all-new interface and unique layout. Control the screen via touch (swipe, scroll, pinch/zoom) or Rotary Controller.

App Tray



5660162

Along the left side of the screen, commonly used features are represented by icons. Tap the HOME icon at any time to return to the Home screen, or tap a different icon for quick access to the app.

Tip: Press and hold, then drag and drop your favorite icons from the Infotainment Screen into the App Tray.

Home View



5660163

The Home screen farthest to the left (swipe from left to right to reach it) features widgets that provide a snapshot of common vehicle features. Tap any widget to see additional details, or press and hold to replace the widget.

App View



5660164

Swipe to reach additional Home screen pages, which display the features of the system represented by app icons, such as AUDIO, PHONE and REAR CLIMATE. Tap any icon to see additional details. The layout of the screen automatically adjusts based on how you are interacting with the system:

Touch: When you are interacting with the screen via touch, apps appear in a traditional, linear layout



5660165

Rotary view: When you are using the Rotary Controller, apps change to a carousel-style view for easier control

Tip:

Rearrange the order of the apps on the screen by pressing and holding, then dragging and dropping the icons. To move an icon to a different page, first drag it to the dashes on the bottom of the screen.

Status Pane

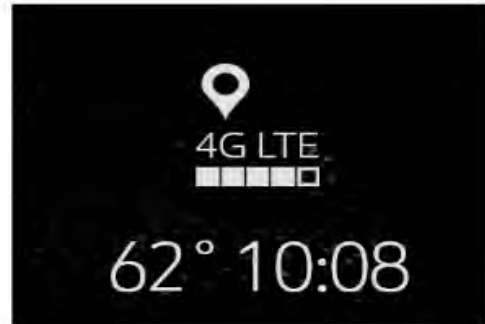

5660166

View the time of day, outside air temperature and other status indicators in the bottom-right corner of the screen.

Personalization

There are many ways to customize the all-new Cadillac user experience to your liking.

Personal Profile

View the time of day, outside air temperature and other status indicators in the bottom-right corner of the screen.

Set up your Personal Profile and associate it with your key fob so your preferences and settings are stored.

- Tap the USERS icon and accept the User Terms and Privacy Statement
- Tap "Create a Profile"
- Associate your profile with your key fob, if desired
- Enter the email address you use to log into Owner Center

Note: If you skip profile setup, you will be using the system as a Guest. Your settings will be saved but not associated with your key fob.

Ambient Lighting

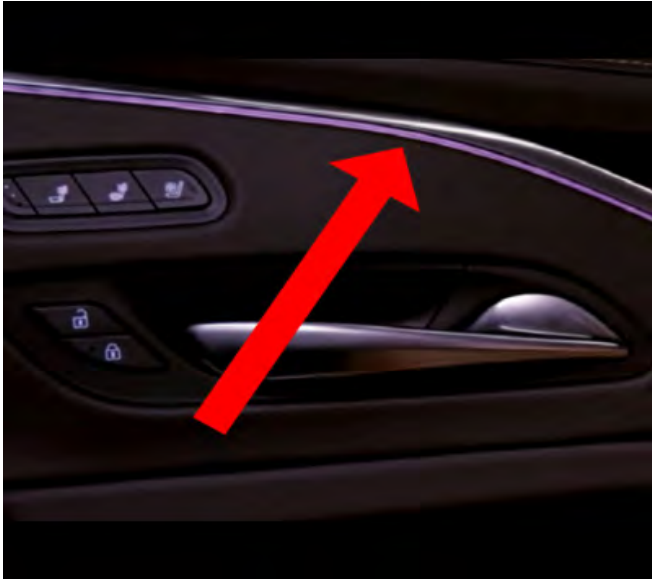

5660167

Tap the AMBIENT LIGHTING icon on the Home screen to select and control your preferred color for the interior lighting.

Settings

Many system preferences are available in the Settings menu. Tap the SETTINGS icon on the Home screen to explore options. Examples of the options include:

- Select Settings > Display to set your Cluster Display right zone content
- Select Settings > Conversation Enhancement to adjust your settings for the feature, which amplifies the volume of passengers' voices in the vehicle.

Phone

Pairing a phone with the all-new Cadillac user experience via Bluetooth®5 is simple and quick. Once you complete pairing, you will have access to your contacts, music and more through the system.

Pairing a Phone

There are three ways to pair a compatible phone:

1. Manually pair:

- Tap the PHONE app icon on the Home screen of the infotainment system
- Select "+Connect Phone"
- Follow the prompts on the screen and on your phone to complete pairing

2. Pair with voice recognition:

- Press and release the PUSH-TO-TALK button on the steering wheel
- At the prompt, say "Pair phone"
- Follow the prompts on the screen and on your phone to complete pairing

3. One-touch pair:

Requires Near Field Communication compatible phone.

Note: Not all NFC-capable phones are compatible with the system. Visit MY.CADILLAC.COM/LEARN for a list of compatible phones.

- Enable Near Field Communication (NFC) and Bluetooth in your phone's settings
- Tap the PHONE icon on the Home screen of the Infotainment Screen, then "+Connect Phone"
- Hold your unlocked phone with the NFC antenna near the top of the Infotainment Screen in the location of the arrow on the display
- Follow the prompts on the screen and on your phone to complete pairing

Navigation

Augmented Reality View

Route guidance and upcoming turns appear as graphics on top of the front camera image within the cluster display. After you enter your destination and start your route, select "AR Camera" from cluster selection menu on the Control Panel (left of the steering wheel) while navigating to see this view.

Voice Prompts

From the Navigation Settings menu, select "Navigation Voice Control" to adjust the audible route prompts. Choose "Directional Navigation" to hear the prompts from the direction of the most relevant speaker in the vehicle (e.g., from the right A-pillar speaker if there is a right turn ahead; or from the left C-pillar speaker if you have missed a left turn that is now behind you).

Google Street View

When searching for a destination on the Infotainment Screen, use the center knob on the Rotary Controller or swipe on the screen to virtually look around the street and surrounding area at the selected address, if it is available. The 360-degree view is powered by Google Street View mapping service.

Note: Not available in cluster view.

Connected Navigation (Requires Trial or Paid Plan)

The available Connected Navigation services enhance the embedded experience by providing up-to-date information, including nearby Points of Interest (POIs), traffic, fuel prices, parking assistance and more.

Vehicle Information

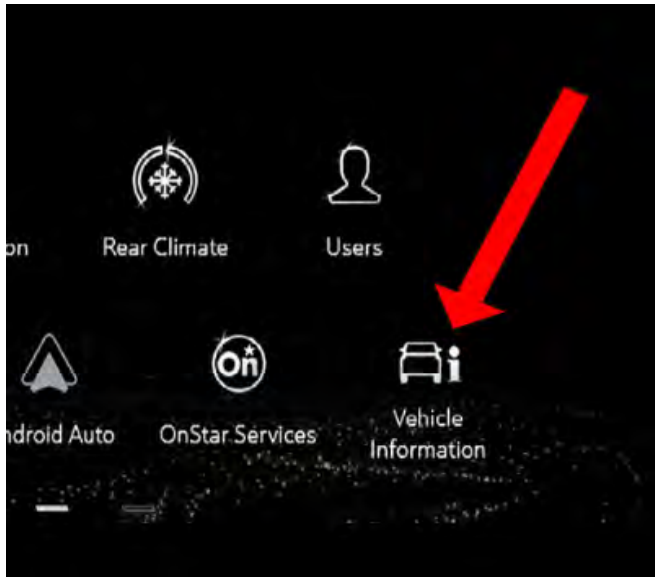

5660168

A new VEHICLE INFORMATION app on the Infotainment Screen displays important vehicle statuses, such as tire pressure and fuel economy. You can also choose to show this content in the cluster display by making your selections on the Infotainment Screen.

Tap the VEHICLE INFORMATION icon on the Home screen to view content (depending on vehicle equipment) such as:

- Air filter life
- Average speed
- Battery voltage
- Brake pad life
- Coolant temperature
- Date and time
- Diesel Exhaust Fluid (DEF) level
- Engine hours
- Fuel economy
- Fuel filter life
- Lane Change On-Demand
- Off road information
- Oil life
- Oil pressure
- Timer
- Tire pressure (excluding spare tire)
- Trailer brake controller
- Transmission fluid temperature

Display Vehicle Information in the Cluster



5660169

Choose vehicle information to display in the cluster by selecting it from the VEHICLE INFORMATION app in the Infotainment Screen—you will not use the steering wheel controls to browse this information. To display content, tap the VEHICLE INFORMATION icon on the Home screen, find and select your desired content, then select “Show in cluster.” To remove it, select “Remove from cluster.”

Key Features

Android Auto

Connect your compatible phone to use Android Auto⁹ via wired or wireless connection:

- Wired connection: Plug your phone’s USB10 cable into a USB port and tap the ANDROID AUTO icon on the infotainment system Home screen; follow the prompts to connect
- Wireless connection: When pairing via Bluetooth[®]; follow the prompts to start a wireless Android Auto session

Apple Carplay

Connect your compatible phone to use Apple CarPlay¹¹ via wired or wireless connection:

- Wired connection: Plug your phone’s Lightning[®] cable into a USB port and tap the APPLE CARPLAY icon on the infotainment system Home screen; follow the prompts to connect
- Wireless connection: When pairing via Bluetooth; follow the prompts to start a wireless Apple CarPlay session
- Add section of content (replaces Conversation Enhancement)

Sirius XM with 360L

The SiriusXM with 360L¹² interface provides an enhanced in-vehicle listening experience for subscribers, with unique channels, more relevant personalized recommendations, visually appealing screens and more ways to discover content.

Camera Technology

Multiple camera views provide visibility around the vehicle (depending on the camera equipment on the vehicle). Tap the CAMERA app icon on the Infotainment Screen, then toggle between different available views.

Tip: In 3D Overhead View, you can rotate the vehicle to see around the perimeter using the Rotary Controller center knob.

AKG Audio System

The AKG Audio System integrates mind-opening sound and technology to provide an undistorted, immersive listening experience. The multichannel audio system includes speakers and amplifiers, finely tuned to deliver studio reference sound.

- Surround Technology: Provides studio reference level, multidimensional sound experience, which you can adjust based on your preferences
- Conversation Enhancement: Microphones and speakers throughout the vehicle amplify the speaking volume of passengers to help make conversation between the front and back of the vehicle easier. This feature varies depending on the vehicle's sound system.
 - From the vehicle Settings menu, select “Conversation Enhancement” to customize the feature (On/Off; Rear Off; Normal/High)
 - Or, use the CONVERSATION ENHANCEMENT button on the steering wheel to turn the feature on or off
 - A white icon will indicate the system is inactive due to an open door, window, liftgate or sunroof. A green icon indicates the system is active
- Navigation Rendering: Helps make your embedded Navigation instructions more intuitive with directional prompts and intuitive sound positioning
- Front Passenger Volume Control (with AKG Studio Reference system only): The front-seat passenger can independently control their audio volume based on their preferences

Rear Seat Media

Rear Seat Media (if equipped) allows you to:

- Utilize HDMI ports and brought-in streaming media devices to watch movies or television shows
- Use the USB port to stream downloaded content or music from USB media players (e.g., Roku® or Firestick)
- Swipe/fling on the rear screens to easily share content between the two rear screens
- Send Navigation suggestions to the driver or check the estimated time of arrival
- Control the system from the front Infotainment Screen (turn the screens on/off, listen in on what's currently playing, lock the system and more)

Rear Seat Entertainment

System Components

The available rear seat infotainment system includes:

1. two seat headrest display screens
2. rear consumer port
3. up to 4 pairs of wireless headphones

System Operation

Display 1 is a smart device and is connected to the radio via Ethernet. Display 1 is connected to Display 2 and the rear consumer port via a low-voltage differential signal cable. The radio controls each display with a remote enable circuit. The rear seat infotainment system is entirely controlled by touch screen inputs. There are no remote controls or external buttons.

To turn the rear seat infotainment system ON, touch anywhere on the desired display and the home screen will display. The home screen is divided into a bottom status bar and three control panels. The bottom status bar provides the home button, current time, access to system settings, Bluetooth® headphones settings, and a power button to turn OFF the associated screen. USB devices can be used for audio and video. Bluetooth® HDMI devices can be paired to the system and smart phones can be paired as media devices.

Display Screens



5619569

Display 1 is located at the rear of the passenger seat. Display 1 is a programmable display and is connected to the radio via Ethernet.

Display 2 is located at rear of the driver's seat. Display 2 is non programmable and only displays the signal communicated from Display 1 via a low-voltage differential signal cable.

The rear displays utilize a 32cm (12.6-in) fixed 16×9 aspect ratio, touch screen LCD with 1920×1080 pixel resolution. The factory default/power reset for both displays is OFF (including audio).

Rear Consumer Port

The rear consumer port connects to Display 1 via a low-voltage differential signal cable. The rear consumer port includes the following inputs:

- USB (audio and video)
- HDMI 1
- HDMI 2
- Miracast

USB

Along with the USB port in the rear consumer port, any USB port in the vehicle can provide USB content for the rear seat infotainment system. The USB devices are for audio and video.

HDMI

The HDMI input allows an HDMI audio/video cable connection from an auxiliary device, such as a camcorder or video game system. For certain HDMI devices supporting USB charging, the USB ports can provide power to the source.

Miracast

Note: Apple does not support the Miracast standard.

The rear seat infotainment system Wi-Fi supports Miracast to display smart devices directly on the rear seat infotainment screens. Miracast only supports one device at a time. The smart device must support Miracast, screen mirroring, or Android Wireless Display.

Wireless Headphones

The rear seat infotainment system includes two or four pairs of 2-channel digital wireless headphones. Wireless headphones allow for rear seat passengers to listen to an audio source without disturbing front seat passengers. The wireless headphones receive audio signals from the infrared transmitter located on the top of the left seatback display.

A power button on the headphones turns them off or on. A red Light Emitting Diode (LED) illuminates when the headphones are ON. The headphones automatically turn OFF if the infrared signal from the system is lost for approximately 4 minutes to preserve battery life. The signal may be lost if the system is turned off or the infrared signal is out-of-range of the transmitters.

Each set of headphones has a rotary volume control on one of the earpieces.

Audio to the wireless headphones is provided over 2 channels. Audio for channel 1 or channel 2 is selected by pressing the button in the center of the headphone volume control.

The system supports Bluetooth® headphones. Up to 9 pairs of Bluetooth® headphones can be paired to each rear display.

Secure Digital Card Reader, USB Port, and Auxiliary Audio Input Jack

A secure digital card reader, a USB port(s), and/or an auxiliary audio input jack may be part of an assembly for use by the infotainment system. Located in the center console, the assembly receives fused battery voltage and ground from the vehicle harness. The

vehicle harness provides power to a hub device integral to the assembly and provides additional amperage to allow the USB port to power devices.

The internal hub device interfaces directly with the remote radio receiver via a standard USB cable. An inline cable connection is typically found between the console and instrument panel harness.

Secure Digital Card Reader

On vehicles equipped with navigation, the secure digital card will contain the map information for the vehicle region.

USB Port

Note: Not all portable media player devices or file types are compatible. Connection to USB hub devices is not supported.

The USB port allows the user to send information to the infotainment system from portable media players or a USB storage device. When a device is connected to the USB port, it can be controlled from the radio controls.

Auxiliary Audio Input Jack

A 3.5mm (1/8-in) auxiliary audio input jack is located in the center console. When a portable audio playback device is connected to the auxiliary jack, an internal switch detects the connection. The radio will then switch to the auxiliary audio input jack as the audio source. The device sends audio signals to the radio from the auxiliary jack via USB.

Auxiliary Power Outlets

Accessory power outlets for electrical equipment, such as a cell phones or MP3 players, are located under the climate control system.

The vehicle is equipped with a 110/230 volt Alternating Current (AC) outlet on the rear of the center console and the cargo area for third row seating. Lift the cover to access the outlets and close the cover when not in use. In regions outside of the USA, the AC outlets are available in 230 volts.

Operation

The accessory DC/AC power inverter module receives fuse protected battery voltage. The 110/230 volt accessory power receptacle has an internal switch that detects when an AC powered device is plugged into the outlet. The accessory AC power system is protected against circuit overload and circuit shorts to ground.

Power Outlet Receptacle Isolation Fault Protection

In addition, the power inverter module contains a ground fault circuit interrupter. The ground fault circuit interrupter monitors the 110/230 volt circuit for a short to vehicle chassis ground. If a short to ground is detected, the accessory DC/AC power inverter module turns OFF. The module remains OFF until the AC powered device is disconnected from the outlet and then plugged into the outlet after a 3 second delay.

Power Outlet Receptacle Overload Shutdown



5619570

The accessory DC/AC power inverter module turn OFF if the current in the 110/230 volt outlet (shown circled above) is greater than 3.8 amps for 1 second or 2.5 amps for 10 seconds. The module turns ON when the AC powered device is disconnected from the outlet and then plugged into the outlet after a 3 second delay.

OnStar®

When OnStar® is activated, a serial data message is sent to the audio system to mute all radio functions and transmit OnStar® originated audio. The OnStar® audio is transmitted to the vehicle audio system by the Ethernet circuit. When the audio source is OnStar®, the fade is set to the front, the bass and treble are set to the middle, and the outputs are mono. OnStar® takes priority over any other audio source. On vehicles equipped with OnStar®, the HVAC blower speed may be reduced when the OnStar® system is active to aid in reducing interior noise. When the system is no longer active, the blower speed will return to its previous setting.

OnStar® Cellular, GPS, and Diagnostic Limitations

Proper operation of the OnStar® System is dependent on several elements outside the components integrated into the vehicle. These include the National Cellular Network Infrastructure, the cellular telephone carriers within the network, and the GPS. The cellular operation of the OnStar® system may be inhibited by factors such as the user's range from an analog or digital cellular tower, the state of the cellular carrier's equipment, and the location where the call is placed.

Compass Data

With the base radio, the telematics communication interface control module provides compass and GPS position information on the low speed Info-CAN bus.

In a mid/high radio system configuration without a telematics control module and equipped with GPS, the radio provides the GPS and heading information on low speed Info-CAN.

An external remote compass module is required to transmit the heading and position information on low speed Info-CAN if either:

- the base radio is present in a system configuration with no telematics communication interface control module
- the radio variant without GPS is present in a system configuration with no telematics communication interface control module

Power and Signal Distribution

Overview

The 2021 Cadillac Escalade is designed and engineered with GM's Vehicle Intelligence Platform (VIP). This advanced data communication platform enables key benefits, including increased system capacity and responsiveness, increased over-the-air vehicle software update capability, and enhanced cybersecurity.

GM's Vehicle Intelligence Platform (VIP)

GM's next generation digital vehicle platform enables increased capacity and the ability to better manage technology complexity. Next generation networks include two-wire CAN buses and two-wire Ethernet buses to ensure high speed data transfer and multiple single-wire LIN buses to exchange information between master control modules and other smart devices. Low speed General Motors Local Area Network (GMLAN) networks are eliminated.

Key benefits of next generation electrical architecture include:

- increased system capacity and responsiveness, including the capability of managing over 100 computer modules seamlessly and delivering up to 4.5 terabytes of data processing power per hour
- increased over-the-air vehicle software update capability, including over-the-air software updates (without dealer visits)
- enhanced cybersecurity, with additional system encryption, higher-level security routines, and additional protective features at both hardware and software levels

Controller Area Network Buses

Next generation electrical architecture communication protocol is based on the widely used CAN protocol. CAN buses are used where data needs to be exchanged at a high rate, primarily by a control device using the information to adjust a vehicle system, such as powertrain or body controls.

Each CAN data network consists of two twisted wires, called CAN (+) and CAN (-), with a 120 ohm (Ω) termination resistor at each end of the bus between the CAN (+) and CAN (-) circuits.

Data Transmission

Data transmitted is represented by the voltage difference between the CAN (+) and CAN (-) signals. Logic symbols (1's and 0's) are transmitted sequentially at the following rates:

- CAN 1 = 500 Kilobits per second (Kbit/s)
- CAN 2 = 2 Megabits per second (Mbit/s)
- CAN 3 = 500 Kbit/s
- CAN 4 = 500 Kbit/s
- CAN 5 = 500 Kbit/s
- CAN 6 = 5 Mbit/s
- CAN 7 = 5 Mbit/s
- CAN 8 = 2 Mbit/s
- CAN 9 = 2 Mbit/s
- Private Powertrain CAN Bus

A logic "1" is transmitted when both CAN (+) and CAN (-) signal circuits are at rest and at the same voltage of 2.5 V. The differential voltage is approximately 0 V.

A logic "0" is transmitted when the CAN (+) signal circuit is driven higher to about 3.5 V and the CAN (-) circuit is driven lower to about 1.5 V. The differential voltage then becomes approximately 2.0 (+/- 0.5) V.

Ethernet Buses

Ethernet is a data communication technology that uses a single twisted copper pair of wires at speeds of 100 Mbit/s and 1000 Mbit/s. The Ethernet system uses point-to-point communication that is connected via an Ethernet switch [Module <--> Switch <--> Module]. The Ethernet bus does not use terminating resistors. The Cadillac Escalades incorporate an Ethernet audio video bridging bus in place of a Media Oriented Systems Transport (MOST®) network.

The K56 serial data gateway module and the A11 radio have an Ethernet switch that connects to other Ethernet modules. The K56 serial data gateway module and the A11 radio communicate with other devices and systems in the vehicle via CAN and LIN buses. DTCs will be read on CAN to diagnose Ethernet, LIN, and system faults.

Note: Ethernet harness failures should only be repaired using an appropriate kit to perform de-pin/re-pin overlays; in cases where the wiring harness repair kits are not available, the entire harness should be replaced. No crimps or splicing should be performed on the Ethernet wiring harness.

Ethernet 1

The Ethernet bus 1 consists of two twisted pairs of wires—one pair for Ethernet bus 1R (circuits 4972 and 4973) and one pair for Ethernet bus 1T (circuits 4974 and 4975). It is connected between the X84 DLC and K56 serial data gateway module. This bus is used for diagnostics and service programming of control modules using Ethernet instead of CAN. The K56 serial data gateway module will convert Ethernet serial data to CAN as necessary, and vice versa. There is an Ethernet enable circuit (circuit 7207), which can be used to wake up the K56 serial data gateway module for Ethernet diagnostics and programming.

Ethernet 2

Ethernet bus 2 (circuits 4757 and 4758) is for connection between the A11 Radio and the K56 serial data gateway module.

Ethernet 3

Ethernet bus 3 (circuits 7208 and 7209) is for connection between the K56 serial data gateway module and the K179 automated driving mapping module.

Ethernet 4

Ethernet bus 4 (circuits 7210 and 7211) is for connection between the following control modules:

- K56 serial data gateway module and K73 communication interface module for vehicles equipped with IOR radio
- A11 Radio and K73 communication interface module for vehicles equipped with other radios

Ethernet 5

Ethernet bus 5 (circuits 7212 and 7213) is for connection between the A11 radio and the P22F video display - passenger seat back.

Ethernet 6

Ethernet bus 6 (circuits 7214 and 7215) is for connection between the A11 radio and the T3 audio amplifier.

Ethernet 7

Ethernet bus 7 (circuits 7216 and 7217) is for connection between the K56 serial data gateway module and the P16 instrument panel cluster control module.

Ethernet 11

Ethernet bus 11 (circuits 7224 and 7225) is for connection between the K124 image processing module and K179 the automated driving mapping module.

Ethernet 14

Ethernet bus 14 (circuits 7230 and 7231) is for connection between the A11 radio and the P29 head-up display.

Ethernet 15

Ethernet bus 15 (circuits 7232 and 7233) is for connection among the K56 serial data gateway module, K161 vehicle performance data recorder, and P22F video display - passenger seat back.

Local Interconnect Network Buses

LIN buses are single-wire buses that exchange information between the master control module and subordinate smart devices. LIN buses communicate at a rate of up to 10.417 Kbit/s. The K9 body control module is wired to multiple LIN buses and acts as a gateway between them.

Local Interconnect Network Bus Data Transmission

Data transmitted is represented by voltage difference expressed in logic symbols (1s and 0s) and transmitted sequentially:

- When a LIN bus is at rest and is not being driven, the signal high voltage state is approximately battery voltage. This represents a logic “1”.
- When a logic “0” is transmitted, the signal voltage is low to about ground (0.0 V).

K9 Body Control Module

The K9 BCM communicates through multiple communication buses to control the vehicle’s body systems. The BCM is wired to the CAN 2 serial data bus and multiple LIN buses and acts as a gateway between them. Some inputs, outputs, and messages require other modules to interact with the BCM. The BCM is located in the passenger compartment, behind the driver side of the instrument panel, outboard of the steering column.

K56 Serial Data Gateway Module

The K56 serial data gateway module handles communication between multiple buses and control modules, as well as buses and the X84 data link connector.

- CAN 1, CAN 2, CAN 3, CAN 4, CAN 5, and CAN 8 buses are used to communicate between the K56 serial data gateway module and other CAN control modules.
- CAN 6 and CAN 7 buses are used to communicate between the X84 Data Link Connector and the K56 serial data gateway module. They are also used for diagnostics, and programming.
- The Ethernet AVB bus is used to connect the radio and K56 serial data gateway module.

Cyber Security

The K56 serial data gateway module also functions as a gateway to isolate the secure networks from the unsecured networks.

Isolating secure networks from unsecured networks supports cyber security. Isolating primary networks helps ensure advanced driver assistance systems and active safety features, such as enhanced collision avoidance, can all operate in conjunction with each other. If harmful software enters the vehicle through the infotainment system, OnStar®, or the DLC, other vehicle systems may be affected, including critical powertrain and safety systems.

The serial data gateway module can learn the diagnostic addresses list of CAN control modules, identify the CAN control modules on the vehicle, and the location of the CAN control modules’ CAN buses. If the serial data gateway module is replaced, this learn/verification process must be performed again through the Serial Data Gateway Module Programming and Setup procedure in Service Programming System (SPS). The learn process does not cause any previously learned contents to be forgotten or overwritten. If the learn process is not performed on a new serial data gateway module, DTC U1977 sets until the learn procedure is executed. If the learn is invalid

due to control module internal malfunction or a serial data gateway module swap, DTC U3000 42 or DTC U3002 56 sets. If these DTCs set, the serial data gateway module enables a loss of communication for all CAN control modules. This results in loss of communication DTCs set against CAN control modules not present on the vehicle.

A malfunction can be localized by monitoring the normal mode messages on a CAN bus. The serial data gateway module monitors one signal per CAN control module per CAN bus to determine control module status. When a signal times out, a loss of communication event will be started.

Power Moding

In next generation electrical architecture, the K9 BCM is the Power Mode Master (PMM) and the K56 serial data gateway module is the back-up PMM.

There are five power modes:

- OFF
- ACCY
- RUN/SERVICE MODE (Engine Off)
- PROPULSION (Engine On)
- Start

As the PMM, the BCM uses a number of vehicle states and inputs to determine which power mode is required. It then reports this information to other modules via serial data and provides associated electrical signals to the entire vehicle to ensure proper feature operation.

The backup PMM, the K56 serial data gateway module, is responsible for determining and sending a system backup power mode serial data signal along with the other related signals to downstream features when the power mode master is unavailable.

Modules with switched voltage inputs may operate in a default mode if the power mode serial data message does not match what the individual module can see from its own connections.

Automatic Power Mode Timeouts

Automatic power mode timeouts prevent batteries from losing charge if the ignition is left on (RUN/SERVICE MODE – Engine Off) while the vehicle is unattended, and the timeouts also shut the vehicle off if it is left running unattended (PROPULSION – Engine On). After a timeout, the BCM power mode master shuts the engine down. This power mode timeout strategy uses vehicle speed, vehicle power mode, parked status, and other vehicle conditions to determine the timeout. Refer to Service Information (SI) for power mode description and operation.

System Diagnostics

K56 Serial Data Gateway Learn Process

To signal any loss of communication and set DTCs, the K56 serial data gateway module must know and learn the control modules on the vehicle and their associated buses.

If the K56 serial data gateway module is replaced or another module is added to the bus, such as a dealer installed accessory, a learn process must be done using the serial data gateway module learn procedure in SPS.

The serial data gateway learn process may be performed by a technician or automatically sequenced as part of a control module programming event.

- Technician selectable option: The learn process may be performed by a technician when a DTC is present, with no control module programming required.
- Automatically sequenced as part of a control module programming event: The learn process may be automatically sequenced after programming a module.

The learn process will not cause any previously learned contents to be forgotten or overwritten.

- If the learn process is not completed on a new K56 serial data gateway module, DTC U1977 will be set until the learn procedure is executed.
- If the learn process is invalid due to internal malfunction or a K56 serial data gateway module swap, DTC U3000 42 or DTC U3002 56 will be set. The K56 serial data gateway module will then lose communication with all control modules and set DTCs against control modules not on the vehicle.

A fault can be localized by monitoring the normal mode messages on a CAN bus. The K56 module will monitor one signal per CAN control module per CAN bus to determine control module status. When a signal times out, a loss of communication DTC sets. The K56 serial data gateway module will create a freeze frame for U codes.

Module Programming

Refer to the Techline Information System (TIS) terminal for step-by-step control module programming instructions and review the information below to ensure proper programming protocol:

- The key must be OFF during module programming and all doors closed. If a door is opened during programming, other buses will wake up and cause error codes to set.
- DO NOT change the position of the ignition switch during the programming procedure unless instructed to do so.
- Options need not be selected during SPS programming.

Odometer Strategy

With next generation electrical architecture, the odometer value is stored in multiple modules. The BCM is the primary storage module and accumulator of vehicle mileage data. The instrument panel cluster control module is a secondary storage module. There is no provision for entering odometer information from any external source such as SPS programming. Any odometer information required for an odometer learning procedure must come from vehicle modules. The

automated process removes any need for technician input and keeps all stored odometer values synchronized.

Over-the-Air Updates

The next generation digital vehicle platform enables over-the-air programming for all control modules with the following provisions:

- The vehicle must be in PARK (P).

Once the download is accepted the following will occur:

- The download will occur while the vehicle is being driven.
- Once the vehicle is stopped and in PARK (P), the driver must accept or decline the programming event.
- If accepted, programming will begin automatically after the driver exits the vehicle.
- The vehicle may not be used, operated, or locked while programming is in progress.

Multiple Diagnostics Interface 2



5619571

Next generation electrical architecture in the 2021 Cadillac Escalade requires the GDS 2 scan tool and MDI 2 for diagnostics. MDI 1 will not work for diagnostics.

When a scan tool is installed, it will attempt to communicate with every control module that could be optioned into the vehicle. If an option is not installed, the tool will display NO COMMUNICATION for that control module. In order to avoid misdiagnosis of a NO COMMUNICATION message, refer to [Data Link References](#) for a list of control modules and the buses with which the modules communicate. Use schematics and specific vehicle build RPO codes to determine optional control modules.

X84 Data Link Connector

The X84 DLC is a standardized 16-cavity connector. Connector design and location are dictated by an industry-wide standard and are required to provide the following:

- Terminal 1: CAN 7 Serial Data (+)
- Terminal 2: Private Presentation 1 CAN Serial Data (+)
- Terminal 3: Ethernet Bus 1R (+)
- Terminal 4: Scan tool power ground
- Terminal 5: Common signal ground
- Terminal 6: CAN 6 Serial Data (+)
- Terminal 7: Private Presentation 2 CAN Serial Data (+)
- Terminal 8: Ethernet Bus 1 Enable
- Terminal 9: CAN 7 Serial Data (-)
- Terminal 10: Private Presentation 1 CAN Serial Data (-)
- Terminal 11: Ethernet Bus 1R (-)
- Terminal 12: Ethernet Bus 1T (+)
- Terminal 13: Ethernet Bus 1T (-)
- Terminal 14: CAN 6 Serial Data (-)
- Terminal 15: Private Presentation 2 CAN Serial Data (-)
- Terminal 16: Scan tool power, B+

Industry standards require the following, and all others are at the discretion of the OE:

- Terminal 4: Scan tool power ground
- Terminal 5: Common signal ground
- Terminal 6: CAN 6 Serial Data (+)
- Terminal 14: CAN 6 Serial Data (-)
- Terminal 16: Scan tool power, B+

Power Receptacles

The 2021 Cadillac Escalade may be equipped with multiple 12 volt accessory power receptacles and two 110/230 volt accessory power receptacles. The 12 volt accessory power receptacles receive their power through the accessory relay.



5619572

1. Type C USB Port
2. Type A USB Port
3. 12 Volt DC Outlet

Instrument Panel Accessory Power Receptacles



5619573

1. SD Card Slot
2. Type C USB Port
3. Type A USB Port

Center Console SD and USB Ports

Rear Receptacles

The accessory DC/AC power inverter module requires a supply voltage between 11 and 16.5V and shuts down if the voltage is not within these limits. The module also shuts down when its internal temperature exceeds 85° C (185°F).

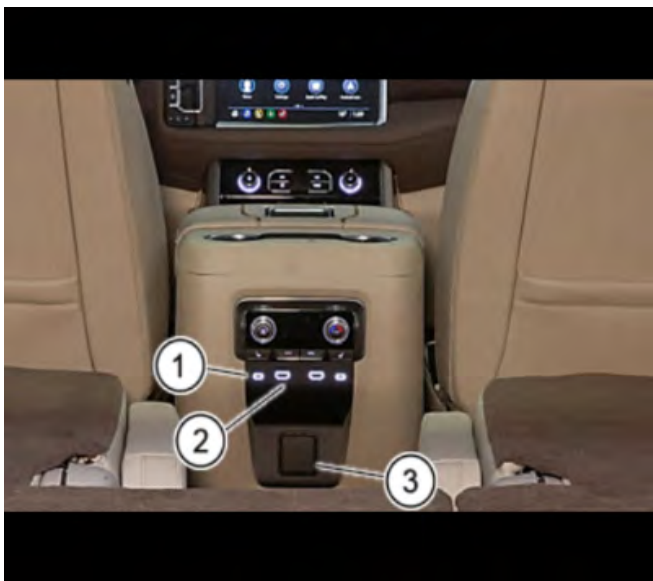

5619574

1. Type C USB Port
2. Type A USB Port
3. 110 Volt AC Outlet (United States)

Rear Compartment Accessory Power Receptacle

The 110/230V (depending on region) AC outlet is located next to the rear USB ports. The rated output is 150 watts.



5619575

The receptacle has an internal switch that detects when a device is plugged into the outlet. When the ignition is on or retained accessory power is active and a device is detected, the DC/AC power inverter module provides power after a 1.5-second delay. The module has built-in protection against over-current. If the module detects over 3.8 amps for 1 second or over 2.5 amps for 10 seconds it turns off the outlet.

Once the protection turns off the outlet, the device needs to be disconnected and then reconnected before the module restores power after a 3-second delay.

Auxiliary Battery

The BCM monitors battery positive voltage to determine the battery state of charge. If one or more of the BCM battery positive voltage terminals measure less than about 11.6V compared to the BCM ground circuits, the BATTERY LOW START VEHICLE message displays and chimes may sound.

Start the vehicle immediately. If the vehicle is not started and the battery continues to discharge, the climate controls, heated seats, and audio systems will shut off and the vehicle may require a jump start. These systems will function again after the vehicle is started.

Safety and Security

Overview

The 2021 Cadillac Escalade are available with segment-leading safety and security technologies such as the surround camera system, pedestrian mitigation braking, and the safety alert seat.

Supplemental Inflatable Restraint System

A solid vehicle structure, coupled with SIR system components, helps maximize protection for vehicle occupants in the event of a collision. The SIR system supplements the protection offered by the seat belts and includes up to ten frontal and side impact air bags, as well as the restraint control module, seat belt pretensioners (anchor and retractor), and impact sensors.

Up to ten air bags may be in the following locations:

- steering wheel
- instrument panel – passenger side
- driver and passenger side knee bolster
- driver and passenger side roof rail
- front driver inboard and outboard seat side
- front passenger outboard seat side
- second row seating outboard left and right seat side

Restraint Control Module

The restraint control module is the control center for the SIR system and contains both internal and external impact sensors. In the event of a collision, the module compares the signals from these sensors to a value stored in its memory. When the generated signals exceed the stored value, the control module applies current to the appropriate deployment loops in order to deploy the air bags.

Deployment Operation

When a deployment occurs, the restraint control module performs the following steps:

1. The module records the SIR system status and illuminates the SIR system AIR BAG indicator located on the instrument cluster.
2. The module performs continuous diagnostic monitoring of the SIR system's electrical components and circuitry when the ignition is turned on.
3. If a malfunction is detected, a Diagnostic Trouble Code (DTC) will be stored and the inflatable restraint control module requests the instrument cluster to illuminate the SIR system AIR BAG indicator to alert the driver of the malfunction.

In the event that ignition positive voltage is lost during a collision, the inflatable restraint control module maintains a limited energy reserve for deployment of the air bags.

Note: It is important when disabling the SIR system for servicing or rescue operations to allow the limited energy reserve to dissipate, which could take up to 2 minutes.

Supplemental Restraint Impact Sensors

The SIR system contains a number of impact sensors, depending on available equipment and markets. The impact sensors are inputs to the restraint control module. The sensors for the SIR system are in the following locations:

- Two engine compartment acceleration-based sensors (G-force sensors) are located on the right and left side of the lower radiator support.
- Four pressure-based sensors are located inside the front and rear doors to detect rapid changes in the air pressure in side-impact crashes.

Impact sensors are not part of the deployment loop but instead provide input to the restraint control module. This module contains a microprocessor that performs calculations using the measured inputs from acceleration and pressure sensors. When the generated calculations exceed the stored value, the restraint control module causes current to flow through the deployment loops to deploy the appropriate air bags.

Dual-Stage Frontal Air Bags

The dual-stage steering wheel and passenger instrument panel air bags vary the amount of restraint to the occupant according to the collision severity and passenger seat position. For moderate frontal collisions, the air bags partially deploy (stage 1 of air bag deployment). For more severe frontal collisions, the air bags fully deploy (stage 2 of air bag deployment).

As part of the frontal air bag system, the vehicle also features driver and passenger knee bolster air bags, which deploy to protect the occupants' legs during a frontal collision.

Driver and Passenger Roof Rail Air Bags

Roof rail side-curtain air bags provide head and neck protection to front and rear seat occupants in the event of a side impact or vehicle rollover. The air bags are located along the roof line, above the doors.

The restraint control module monitors the side impact sensors located in the front and rear doors and rear compartment. If a side impact of sufficient force occurs, the restraint control module commands the roof rail air bags to deploy. As the air bags inflate, they deploy downward to cover the pillars and side windows.

Restraints Occupant Classification System Module

The restraints occupant classification system module monitors the type of occupant that is sitting in the front passenger seat. The restraint occupant classification module uses the information to determine whether to enable or suppress the deployment of the passenger instrument panel airbag.

The restraints occupant classification system module consists of the following components:

- electronic control module
- sensor mat in the seat
- seat belt tension sensor
- wire harness

Seat Belt Tension Sensor

The passenger seat belt tension sensor is mounted on the passenger seat belt retractor and measures the amount of tension in a vehicle seat belt.

Passenger Air Bag Indicator

The passenger airbag indicator identifies the status of the passenger instrument panel airbag. The restraint control module momentarily turns on the passenger airbag indicators after ignition is turned ON. If an occupant is not detected in the passenger seat or the occupant type is not appropriate for airbag deployment, the restraints control module illuminates the passenger airbag OFF indicator. If an occupant is detected in the passenger seat, the restraints control module illuminates the passenger airbag ON indicator.

Service Consideration

The restraints occupant classification module is a calibrated unit. When replacing the assembly, all parts in the service kit must remain together. Do not mix any of the old parts with the new parts.

After repairing or replacing a component in the restraint occupant classification system, perform programming and setup.

Airbag Service Precautions

When servicing the SIR system, always wear the required personal protection equipment, including safety glasses and gloves. To successfully repair the SIR safely, follow all of the warnings and cautions as directed by Service Information.

Enhanced Safety Systems Components

The safety systems offered in the 2021 Escalade include various technologies that use radar, camera, and ultrasonic driving assistance.

Frontview Camera Module

The frontview camera is located behind the windshield near the rearview mirror. Looking out at the road ahead, it detects visual cues such as lane markings and vehicles directly ahead within a distance of approximately 60 m (197 ft).

Long-Range Front Radar Sensor Module

The long-range front radar sensor module is located behind the front grille emblem near the vehicle logo and is not directly visible from the exterior. The radar sensor detects and tracks objects up to 200 m (656 ft) immediately ahead.

Active Safety Systems

The active safety system is a comprehensive feature set designed to help a driver avoid collisions or reduce crash damage while driving, backing up, and parking. The K124 Image Processing Module is the primary controller of the 2021 Cadillac Escalades active safety system. The active system includes various control modules and sensors listed below:

- K124 Image Processing Module
- B174W Frontview Camera – Windshield
- B233B Forward Range Radar Sensor – Long Range
- K182 Parking Assist Control Module
- K160 Brake System Control Module

The image processing module communicates via serial data on the object detection bus with the components listed above. The image processing module observes an actual visual image of the area 60 m (197 ft) directly ahead of the vehicle with the frontview camera. The radar sensor module – long range measures the distance to objects that are up to 200 m (656 ft) in front of the vehicle. Within 60 m (197 ft) of the vehicle, all of these inputs are combined to create a fusion image of the area in front of the vehicle. At up to 200 m (656 ft), the radar sensor module – long range detects and begins tracking objects immediately in front of the vehicle. Within 60 m (197 ft), the frontview camera confirms objects detected by the radar sensor module – long range.

Gap Switch

The gap switch allows the driver to determine how closely the adaptive cruise control vehicle follows a target vehicle while adaptive cruise control is engaged. When the adaptive cruise control vehicle speed is being limited due to a slower travelling vehicle, the adaptive cruise control vehicle speed is automatically controlled to the follow speed limit. The gap switch has 3 following distance selections that range from 1–2 seconds.

The gap switch following distance between the adaptive cruise control vehicle and the target vehicle is expressed in time as opposed to actual distance. The distance maintained for a selected gap will vary based on vehicle speed. The faster the vehicle speed, the further back you will follow. The gap setting can only be adjusted when the adaptive cruise control system is engaged. The gap switch is hard-wired to the Body Control Module (BCM). Based on voltage variations,

the BCM reads the gap switch selection and communicates the switch status to the image processing module by Controller Area Network (CAN) signal. The gap switch is a momentary switch.

The initial push of the gap switch recalls the current setting and activates the display. Subsequent pushes of the gap switch will change the gap setting.

If the system detects a possible collision, it alerts the driver with an audible alert. If equipped with a head-up display, a series of red dots will display on the windshield. If equipped with a safety alert seat, the driver will experience a series of pulses on both sides of the seat.

Forward collision alert distance can be set to far, medium, or near timing using a steering wheel control. Adjusting the distance of the forward collision alert system also changes the following distance for adaptive cruise control – advanced, if equipped.

Forward collision alert may be enabled or disabled through the vehicle Settings menu.

Active Safety Technologies

Standard active safety technologies include:

- forward collision alert
- lane departure warning
- automatic emergency braking
- park assist

Alerts can be user set to either a haptic signal using the driver's haptic signal motor seat or beeps using the audio system.

Forward Collision Alert

The forward collision alert uses the frontview camera module to detect vehicles in the path ahead of the vehicle and alert the driver when a collision risk is present. When a vehicle is detected ahead, a green icon is displayed. This indicator turns amber if the driver is following too closely. If the system detects that the driver is seconds away from a possible front-end collision, an alert is displayed, which is a series of red flashing collision alert Light Emitting Diodes (LEDs) on the windshield. An audible alert is simultaneously triggered. If the vehicle is equipped with a safety alert seat (HS1), both sides of the seat will pulse. The forward collision alert system can be set to far, medium, or near timing using the forward collision alert switch and can be turned off using this control or the vehicle personalization.

Automatic Emergency Braking

Forward automatic braking uses the image processing module, frontview camera, and the forward long range sensor to determine and warn a driver when a front-end collision with a vehicle ahead may be imminent.

The system works when driving in a forward gear between 8 to 60 km/h (5 to 37 MPH), on models equipped with adaptive cruise control. The system can detect vehicles up to 60 m (197 ft) ahead.

If the system detects a possible front-end collision, it issues an audible alert of eight high-pitched beeps. If equipped with a safety alert seat, the driver experiences a series of pulses on both sides of the seat.

If the driver does not respond quickly or the situation happens suddenly, the system automatically applies the brakes in an effort to mitigate the collision.

Forward automatic braking may be enabled or disabled through the vehicle settings menu.

Enhanced Automatic Emergency Braking

Front Pedestrian Braking

Front pedestrian braking, if equipped, is a feature subset of front impact mitigation that aims to reduce the likelihood of collisions or reduce the impact speed with pedestrians in the forward direction. The front pedestrian braking system:

- determines the forward path of the vehicle
- monitors this path with respect to pedestrians in or near the forward path
- when appropriate, provides alerts to the driver
- if certain conditions are met, provides autonomous braking to help avoid collision or reduce the impact speed of a collision with the pedestrian

This system is not intended to replace the driver's responsibility to pay careful attention for pedestrian, vehicle, and other potential hazards. Its function is limited to supplemental use only to assist rather than replace the driver in responding to pedestrians while driving.

The front pedestrian braking system can detect and alert the driver of up to ten pedestrians in a forward gear at speeds between 8 and 80 km/h (5 to 50 MPH). During daytime driving, the system detects pedestrians up to a distance of approximately 40 m (131 ft). Pedestrians must be at least 80 cm (31.5 inches) tall for camera detection.

Reverse Automatic Braking

The reverse automatic braking system is designed to help drivers avoid pedestrian collisions while backing up. If the system detects the vehicle is reversing too fast to avoid a collision, it may automatically apply the brakes. The reverse automatic braking system includes the K124 Image Processing Module and the K182 Parking Assist Control Module. In conjunction with the backing warning system, if the driver does not respond to the audible and haptic alerts while backing up, the system automatically applies the brakes and brings the vehicle to a hard stop.

Rear automatic braking also prevents the vehicle from backing into an object if the vehicle is in REVERSE. If the system detects an object immediately behind the vehicle while attempting to reverse from a stop, the brakes are automatically applied.

Pressing the brake pedal after the vehicle comes to a stop releases the rear automatic braking, in addition, it may be also necessary to release the electronic parking brake. When it is safe to do so, pressing the accelerator pedal firmly at any time overrides the rear automatic braking system feature.

If the rear automatic braking system activates with no objects or pedestrians behind the vehicle, check to see that snow, ice, or debris are not present on the rear object sensors.

Rear pedestrian alert can be enabled or disabled through the vehicle settings menu.

Pedestrian Impact Detection System

The available pedestrian impact detection provides protection to pedestrians involved in vehicle impacts. The pedestrian impact detection system or active pedestrian protection system protects a pedestrian impact by raising the hood when a pedestrian is detected during a frontal impact. This provides vertical deformation space under the hood.

In some regions, an active pedestrian impact detection system is required for vehicles which do not provide the required deformation space under the hood.

When a pedestrian impact is detected, the system deploys the hood hinge actuators to lift the rear section of the hood to help reduce pedestrian head injuries. (The term "deployment" applies to the activation of the hood via the hood actuators). The pedestrian impact detection system is designed to sense and discriminate road impacts such as pedestrians or cyclists from other types of impacts to properly deploy the hood actuators. No actions or inputs are required from the driver or passenger to trigger this device. The pedestrian impact detection system operates at vehicle speeds between 22 km/h (14 MPH) to 50 km/h (31 MPH).

After a deployment event, the vehicle's hood can be reset to its normal driving position. In addition, after resetting the hood, the pedestrian impact detection system is not required to be fully functional to drive the vehicle. To restore full functionality of the system, replacement of system component(s) is necessary.

The restraints control module detects internal and interface malfunctions and commands the SERVICE PEDESTRIAN PROTECTION SYSTEM message to display in the driver information center.

Pedestrian Impact Detection Components

The pedestrian impact detection system includes the following components:

- restraints control module
- pedestrian impact detection sensor – upper beam front left
- pedestrian impact detection sensor – upper beam front right
- two hood hinge actuators

Pedestrian Impact Detection Sensors

The restraints control module uses two pedestrian impact detection sensors connected together by a tube to receive force information needed for deployment of the hood hinge actuators. The restraints control module deploys the hood actuators using two deployment loops.

The restraints control module provides a two-wire current loop interface to the pedestrian impact detection right and left front sensors. The control module also provides power and ground to the sensors using the same two-wire discrete interface. The two

sensors are connected together by a tube and are serviced as an assembly. The sensors measure the pressure in the tube. If the pressure changes, the sensor converts the pressure into a voltage signal which is sent to the restraints control module. The restraints control module determines what action to take.

During replacement of the pedestrian impact detection sensors, visually inspect the front fascia and front bumper fascia energy absorbers for cracks or other damage that may interfere with proper operation of the system. Replace damaged components as necessary.

Hood Hinge Actuators

The pedestrian hood actuators deploy only when a valid signal triggers a deployment of the hood. The hood actuator is not expected to deploy in low severity events where the risk of injury is low or in high severity events such as a car-to-car impact.

During a frontal pedestrian impact of sufficient force, the restraints control module applies a current flow through the deployment loops to deploy the hood hinge actuators. The control module also monitors the system and performs continuous diagnostic tests on the deployment loops to verify proper circuit continuity or for circuit malfunctions such as short-to-ground or a short-to-voltage. To prevent unwanted deployment of the actuator during service, the hood hinge actuator contains two shorting bars to short both the high- and low-circuit pins together when the harness connector is disconnected. The restraints control module only commands a deployment when a valid pedestrian impact detection sensor signal or confirmation has been generated. Inadvertent deployments will not occur in any deployment loop due to a single-point malfunction.

Side Blind Zone Alert and Rear Cross Traffic Alert

The available side blind zone alert is intended to assist drivers when changing lanes. The system uses the following components:

- B218L Side Obstacle Detection Control Module – Left
- B218R Side Obstacle Detection Control Module – Right
- K9 BCM
- S79D Front Side Door Window Control Switch – Drive
- S79P Front Side Door Window Switch – Passenger
- A9A Outside Rearview Mirror – Driver
- A9B Outside Rearview Mirror – Passenger
- safety alert seat (HS1)

An integrated function of the side blind zone alert system is lane change alert. Lane change alert supplements the side blind zone alert system by detecting approaching vehicles on either side of the vehicle that may not yet be in the side blind zone alert area. The detection zone for lane change alert starts at the outside rearview mirror and extends out:

- 0.5 to 2.0 m (1.5 to 6.0 ft) from the back corner of the vehicle
- 70 m (230 ft) behind the vehicle at a height of 0.5 m (1.5 ft)
- 2.0 m (6.5 ft) above the ground

When the system detects a vehicle in the side blind zone while driving forward, an amber warning symbol illuminates in the appropriate outside mirror. This indicates it may be unsafe to change lanes. If the driver then activates the turn signal, the amber warning symbol starts flashing as an extra warning not to change lanes

In the event the system senses a malfunction through its diagnostic routines, the system deactivates and the driver is visually notified. Drivers can enable lane change alert in the vehicle personalization menu under collision/detection systems.

Rear Cross Traffic Alert

Rear cross traffic alert is designed to warn of impending rear cross traffic when backing up.

The system only works when the vehicle is in REVERSE at speeds below 10 km/h (6 MPH) to detect and track objects within 20 m (65 ft) behind and to the sides of the vehicle. The system then issues either an audible alert or visual alert in the infotainment display to alert the driver of objects that may cause a collision with the vehicle. If the vehicle is equipped with a safety alert seat, the system issues a haptic warning.

Safety Alert Seat

Based on trim level, the 2021 Cadillac Escalade may be equipped with a safety alert within the driver's seat. Depending on the alert, either the left, right, or both motors activate to alert the driver.

The two motors providing the vibration are located on the left and right sides of the seat cushion. Depending on the alert, either the left, right, or both motors activate to alert the driver as to what side of the vehicle is of concern

The safety alert seat includes the following components:

- K9 BCM (without A45)
- K40 Seat Memory Control Module (with A45)
- P45LR Seat Haptic Motor – Driver Left
- P45RR Seat Haptic Motor – Driver Right



5619577

1. P45RR Seat Haptic Motor – Driver Right
2. P45LR Seat Haptic Motor – Driver Left

Safety Alert Seat Motors

The safety alert seat is used with the following driver assist features:

- The lane departure warning and lane keep assist use the left- and right-side pulses to alert drivers if they unintentionally drift out of their lane
- The rear cross traffic alert uses left- or right-side pulses to indicate the direction of approaching cross traffic when in REVERSE
- The forward collision alert simultaneously pulses on both sides to warn drivers of a possible collision with the vehicle they are following
- Front pedestrian braking simultaneously pulses on both sides to warn drivers of a potential collision with a pedestrian directly ahead.
- Front and rear park assist and backing warning or automatic braking system simultaneously pulse on both sides of the seat when a potential rear collision is detected under low speeds

HD Surround Camera System (UV2)

The surround camera system provides an overhead view of the area surrounding the vehicle. This view aids in entering and leaving parking spaces by reducing the blind spots during low-speed maneuvering. This view also supplements the mirrors on the vehicle and provides a view from the rear or front cameras, depending on the direction of travel. The system uses four cameras to create an overhead view of the area around your vehicle.

HD Surround Camera System Components

The HD surround camera system consists of the following components:

- B87 Rearview Camera
- B174G Grille Mounted Frontview Camera
- K157 Video Processing Control Module

- A11 Radio or K74 Human Machine Interface Module
- B225L Left Sideview Camera
- B225R Right Sideview Camera
- X20 Memory Card Receptacle

HD Surround Camera System Displays

The HD surround camera system displays include the following:

- overhead view alongside a rear camera view displayed in REVERSE
- overhead view alongside a front camera view displayed in NEUTRAL or DRIVE

The surround camera system displays a frontview image when the front park assist object sensor detects an object within 30 cm (12 in) and the vehicle is in a forward gear.

The surround camera system image is removed from the display when the vehicle speed exceeds 10 km/h (6 MPH) or when the system control button is pressed or the infotainment screen control is touched.

There are nine selectable camera views:

1. Surround Vision
2. Rear Camera Mirror
3. Standard Front
4. Standard Rear
5. 1/2 Overhead Front
6. 1/2 Overhead Rear
7. Sideview Front
8. Sideview Rear
9. Hitch View Hitch Guidance

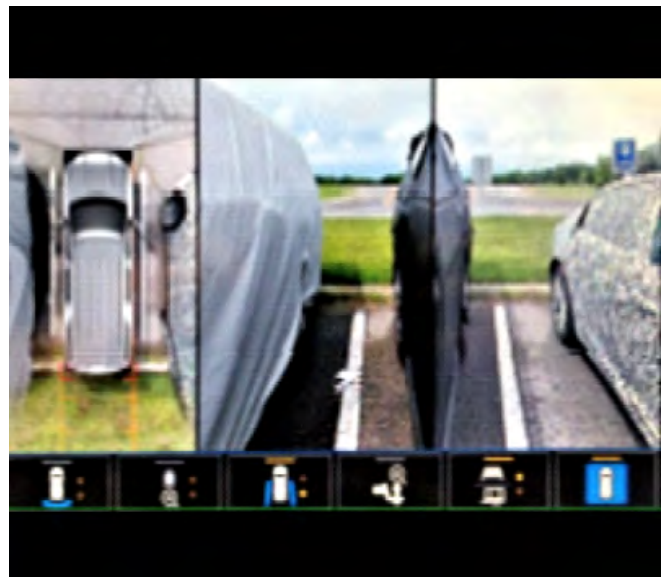

5619578

HD Surround Camera View

A processing module combines the four camera images into a single image that is displayed on the infotainment screen.

HD Surround Camera System Operation

Each camera is connected to the video processing control module by a shielded coaxial cable. The coaxial cable provides power to the camera and sends the video image from the camera to the video processing control module for processing. The video processing control module sends the processed image to the infotainment system via another coaxial cable.

The video processing control module receives information from the rear park assist object detection module, and it receives steering wheel angle information from the BCM while in REVERSE. The video processing control module performs a system camera calibration on every key cycle.

If the rear parking assist detects an object when the vehicle is in REVERSE, a warning triangle may display. This triangle changes from amber to red and increases in size as the object gets closer. Dynamic guidelines are also displayed in REVERSE to show the projected path of the vehicle.

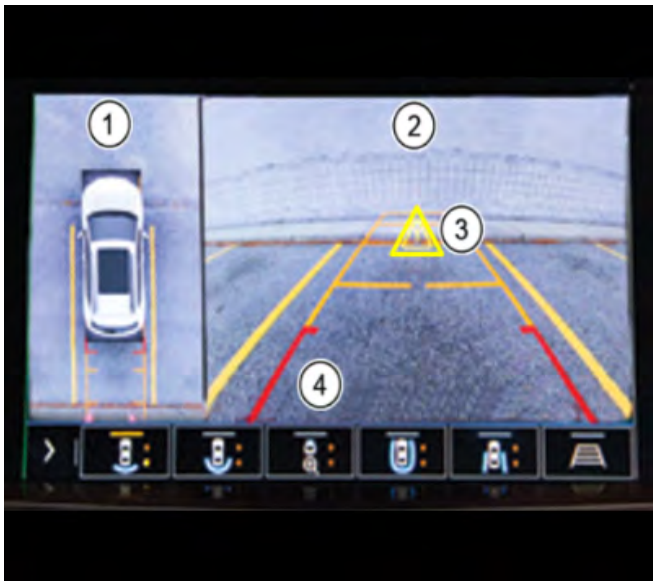

5619579

1. Overhead View
2. Rear Camera View
3. Warning Triangle
4. Dynamic Guidelines

Surround Camera Views on Infotainment Screen

Active Side Safety Obstacle Detection – Extended Trailer View (UKV)

The 2021 Cadillac Escalade is available with an all new trailering system with the following advanced features:

- Application for Infotainment System (Trailer Light APP)
- Application for Infotainment System (Trailing APP)
- sideview cameras
- auxiliary camera to view behind the trailer
- trailer tire pressure monitoring
- automatic parking brake apply
- trailer detection
- pre-departure checklist
- custom profile feature
- trailer lighting sequence and diagnostic
- trailer theft detection
- hitch guidance with hitch view
- surround vision camera

Trailer Vision System

The trailer vision system works similarly to the surround camera system with the addition of a camera mounted to the rear of the trailer. The infotainment system incorporates the added camera into the surround view display to assist the driver when parking a trailer.

Trailer Vision System Displays

The trailer vision system displays include the following:

- overhead view alongside a rear camera view displayed in REVERSE
- overhead view alongside a front camera view displayed in NEUTRAL or DRIVE

Image Quality Considerations

The following conditions may cause a poor quality image:

- ice, snow, or mud built up on the rear vision camera
- darkness
- extreme light conditions, such as glare from the sun or the headlights of another vehicle
- damage to the rear of the vehicle
- extreme high temperatures or extreme temperature changes

Hitch Guidance with Hitch View

With available hitch guidance with hitch view, the infotainment display adds a guided line for the driver to follow back to the trailer hitch. Once the vehicle is in position for the trailer hitch to be lowered onto it, the trailering application will command the vehicle parking brake on so that the vehicle will not roll forward or back when the transmission is placed in PARK.

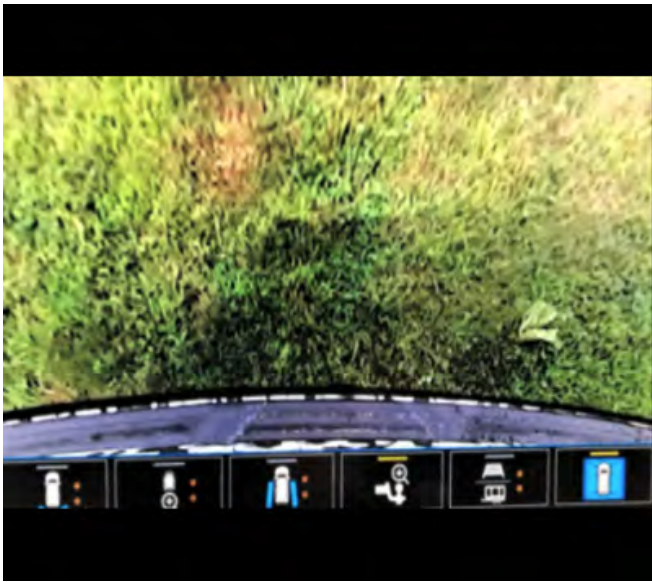

5619580

An image adjustment function allows drivers to pan up and down to better view the trailer hitch when backing up to it.

Trailer Theft Detection

Trailer theft detection is a new optional feature for the 2021 Cadillac Escalade. When activated, the vehicle will flash the exterior lights and cycle the horn to alert of a trailer theft event. If the antenna and the trailer tire pressure monitor kit are included, the trailering application will also monitor the trailer's tire pressure.

HD Digital Rear Vision Camera (UVB)

The HD digital rear vision camera system consists of a rear vision camera and the infotainment system. The rear vision camera system consists of a video camera located at the rear of the vehicle (shown circled above). When the transmission is placed in REVERSE, a signal is sent to the radio, indicating that camera operation is requested. The rearview camera sends video information to the radio through a coax cable. The coax cable also provides power from the radio to the rearview camera.

The following conditions may cause a degraded rear vision camera image.

- ice, snow, or mud built up on the rear vision camera
- dark conditions
- extreme light conditions, such as glare from the sun or the headlights of another vehicle
- damage to the rear of the vehicle
- extreme high temperatures or extreme temperature changes

If a malfunction is detected in the system, a SERVICE REAR VISION CAMERA message may be displayed on the infotainment screen.

Rearview Camera Full Display Mirror (CWA)

The available rearview camera full display mirror with remote wash features an inside rearview mirror that can be used as a standard reflective mirror or to display a high resolution 1280×240 pixel image from a dedicated HD camera. The rear glass washer sprays washer fluid on the camera lens to help keep it clean.

The driver can set preferences on the mirror by pulling on the tab to turn on the mirror, then selecting the check mark, and using the left and right arrow buttons to scroll through the menu and select the following:

- ON/OFF
- brightness
- zoom
- tilt

The rear washer camera system includes a high-resolution digital camera located on the liftgate above the license plate, connected to the outside rearview camera via a shielded coaxial cable.



5619582

When the video monitor is turned off, the mirror acts like a standard reflective mirror with auto dimming features. When the video monitor is turned on, it provides an unobstructed view behind the vehicle, with a field of view approximately 300% wider than a traditional mirror.

Note: The graphic below shows a rear vision zones comparison.

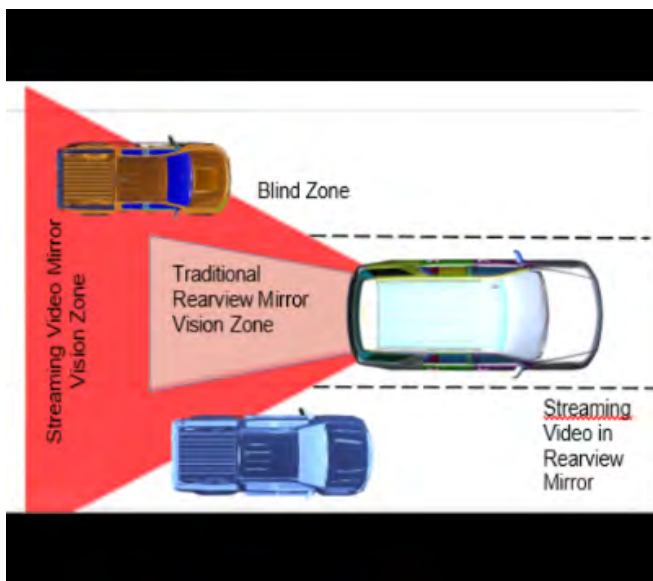

5619584



5619585

The rear washer camera washer nozzle is located on the right side of the camera lens. To activate the camera washer, rotate the inner rear wiper switch on the turn signal/multifunction switch to the upper wash position.

Suspension Systems

Overview

The 2021 Cadillac Escalade features an all-new independent rear suspension with an enhanced magnetic ride, an optional automatic level control suspension, and an available electronic suspension control system.

Front Suspension

The base front suspension is an independent coil spring suspension design, which allows each wheel to compensate for uneven road surfaces without affecting the opposing wheel. Each front wheel independently connects to the frame with steering knuckles, ball joint assemblies, and upper and lower control arms. This design allows each front wheel to compensate for changes in the road surface without affecting the opposite wheel. The upper control arms have been moved up and away from the wheel to enable improved turning radius. The front suspension uses coil springs. There are two optional suspensions, including an automatic level control suspension with variable rate air springs to improve performance under heavily loaded and off-road conditions. The second option is an electronic controlled magnetic ride suspension with dampening coil springs for improved ride and handling.

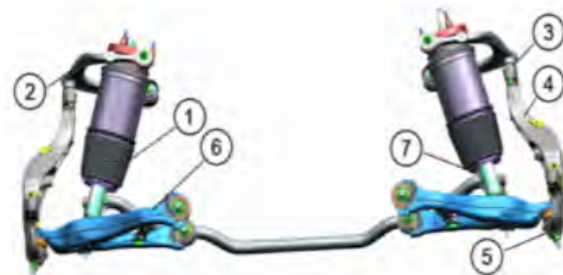

5619587

1. Air Spring
2. Upper Control Arm
3. Upper Ball Joint Assembly
4. Steering Knuckle
5. Lower Ball Joint Assembly
6. Lower Control Arm
7. Shock Absorber

Automatic Level Control Front Suspension

Rear Suspension

The base rear suspension design is an all-new lateral link independent design that uses coil springs.

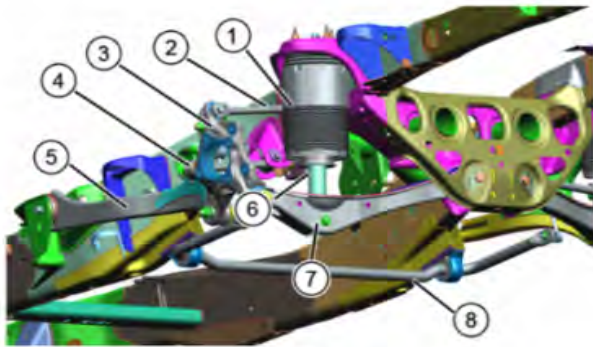

5619588

1. Rear Air Spring
2. Rear Suspension Lateral Link
3. Rear Knuckle
4. Rear Suspension Adjust Link
5. Rear Suspension Trailing Arm
6. Shock Absorber
7. Rear Suspension Lower Control Arm
8. Rear Stabilizer Bar
9. Shock Absorber

Independent Rear Suspension with Automatic Level Control

Automatic Level Control Suspension

The automatic level control suspension features a variable rate spring design at each of the four wheels to improve ride and handling performance under all driving conditions, from rough road conditions to heavily loaded situations.

K5 Automatic Level Control Module

The K5 automatic level control module controls the system functions and monitors the suspension system for proper operation. Other than the selected ride height, the control module uses the following vehicle parameters alone or in combination with one another to establish a target ride height.

- vehicle speed
- lateral acceleration
- longitudinal acceleration
- throttle position
- cruise control status
- transmission range selection status
- stability control system status
- semi-active damping system status
- vehicle power mode
- suspension position sensors
- air spring pressures

Driver Information Center

The automatic level control module monitors the air suspension system. If a malfunction is detected, a serial data message is sent to the instrument cluster to display a SERVICE LEVELING SYSTEM message on the driver information center.

Pneumatic Control Unit

The pneumatic control unit is mounted to and controlled by the automatic level control module. The pneumatic control unit contains the pressure sensor and control solenoid valves for each of the four air springs and determines and directs the airflow throughout the air suspension system. The automatic level control module, pneumatic control unit, and air compressor are located under the rear of the vehicle, above the spare tire, and are serviced separately.

Compressor and Air Dryer

The air suspension compressor is a dual-stage, positive displacement, piston air pump with boost mode driven by a 12 volt DC permanent magnet motor. The air compressor draws air from the atmosphere through the air intake or reservoir and supplies the air to the pneumatic control unit. The air dryer removes moisture from the intake air. In addition, air from the pneumatic control unit directed to the compressor is exhausted into the atmosphere.

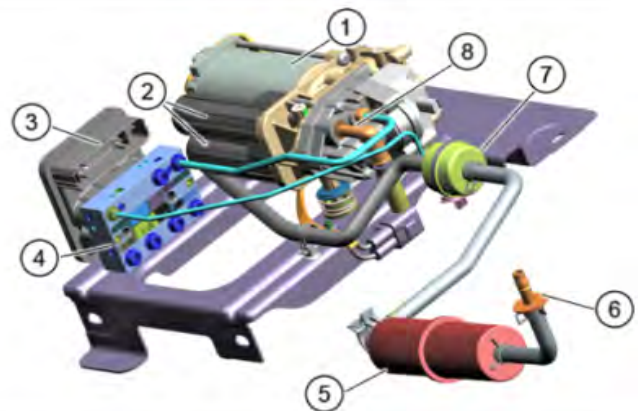

5619589

1. Air Suspension Compressor
2. Air Dryer Assembly
3. Automatic Leveling Control Module
4. Pneumatic Control Unit
5. Air Intake Muffler
6. Air Intake Port
7. Air Intake Particulate Filter
8. Exhaust Air Vent

Compressor, Level Control Module, and Pneumatic Control Unit

Air Suspension Position Sensors

The automatic level control module provides each Hall-effect suspension position sensor with a 5-volt reference and ground. The position sensors provide the control module with a pulse width modulated signal that corresponds to the current height of the vehicle.

Air Suspension Reservoir

The reservoir stores the reserved dry air used to supply the pneumatic control unit. The pneumatic control unit uses this air to inflate the appropriate air spring. The air suspension reservoir is located under the center of the vehicle and is bolted to the frame support rails near the automatic transmission.

Air Springs

Note: The vehicle will not lower when exiting if the level switch is in Off-road, or tow-haul/trailer mode.

The four air springs raise or lower vehicle height based on the automatic level control module inputs. The automatic level control module determines the vehicle height.

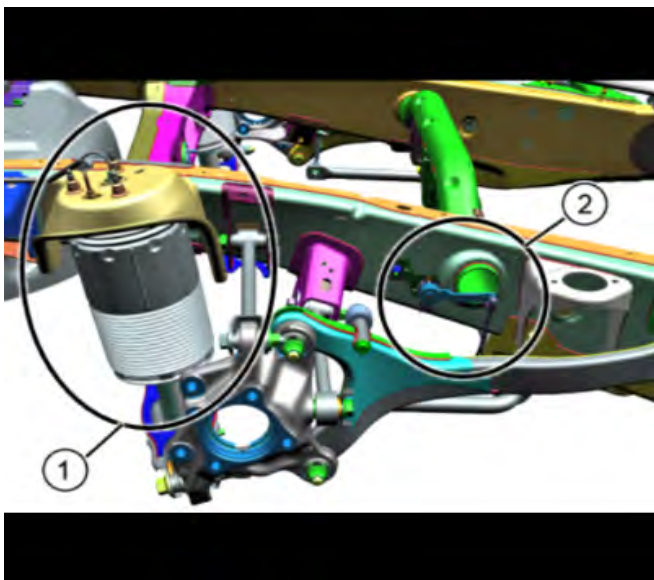

5619590

1. Rear Air Spring
2. Rear Suspension Position Sensor

Rear Air Spring and Position Sensor

Interactive Air Suspension Driver Controls

The interactive air suspension driver control system enables the driver to select four different suspension ride heights:

- Entry/Exit
- Normal
- Increased Ground Clearance
- Maximum



5619591

Note: The Interactive Driver Control Air Suspension Mode Selector is shown circled above.

An additional mode, AERO, may be programmed, but not selected.

When a mode is selected, a message displays on the driver information center indicating the selected ride height.

Entry/Exit

This mode may be programmed in the configurable settings as an option and is selectable using the driver controls. Entry/exit mode automatically lowers the front and rear air suspension 51 mm (2 in.) under the following conditions: every time the vehicle is shifted into PARK and a door is opened to exit the vehicle as well as when a door is opened to enter the vehicle. Lowering takes approximately 8 seconds. The automatic entry/exit mode does not operate when:

- the vehicle is raised above normal ride height
- tow/haul mode is active
- off-road mode is active
- a trailer is attached to the vehicle

Normal

Normal mode is not programmable in the configurable settings. This mode is automatic at predetermined speeds for safety and may be manually selected by the driver.

Increased Ground Clearance

This mode is not programmable in the configurable settings, but may be manually selected by the driver. Available on four-wheel drive vehicles, this mode increases vehicle ride height by 25 mm (1 in.). When the vehicle is in off-road mode or terrain driver mode is active, increased ground clearance is automatically selected.

Maximum Ground Clearance

This mode also is not programmable in the configurable settings, but may be manually selected by the driver when the transfer case setting is in 4-LO. Only

available on four-wheel drive vehicles, this mode increases ride height by 51 mm (2 in.). This feature does not automatically increase ground clearance.

AERO

This mode also is not programmable in the configurable settings, but may be manually selected by the driver when the transfer case setting is in 4-LQ. Only available on four-wheel drive vehicles, this mode increases ride height by 51 mm (2 in.). This feature does not automatically increase ground clearance.

A SERVICE LEVELING UNAVAILABLE message may display for any of the following reasons:

- system thermal conditions
- system voltage is too low but above the Diagnostic Trouble Code (DTC) threshold
- various inhibits or safety situations that do not allow the system to respond to a target height change

Service Considerations

Service Mode Setting



5619593

When the air suspension system is in service mode, all air suspension operations, including raising and lowering the vehicle and air compressor operation, are disabled. Service mode is useful when the vehicle is being towed on a flat bed or during vehicle service when the vehicle is placed on the hoist.

Service mode automatically enables when the vehicle is raised on a hoist or a floor jack. Service mode automatically disables when vehicle speed exceeds 16 km/h (10 MPH). Service mode can be manually enabled and disabled easily through the infotainment center by selecting the Suspension option under the Settings/Vehicle menu.

Note: If the vehicle automatically enters suspension service mode, the vehicle must be driven at a speed of 16 km/h (10 MPH) to disable service mode, or manually disable service mode using GDS2.

Alignment Mode

Alignment mode optimizes the vehicle height to provide the most accurate wheel alignment. Enable this mode when the vehicle is driven onto the alignment rack.

To enable alignment mode, ensure the vehicle is at normal ride height and shift the vehicle into NEUTRAL. Alignment mode automatically disables when vehicle speed exceeds 16 km/h (10 MPH).

Alignment mode can be manually enabled and disabled through the infotainment center. Select the Suspension option under the Settings/Vehicle menu and place the transmission in the NEUTRAL position.

Air Suspension Operation with Door(s) or Hood Open

The air suspension temporarily suspends all height changes while the hood or any door is open.

System Over-Temperature

If the air suspension is under heavy use, the system may temporarily suspend all height changes to allow the air compressor to cool. During this time, if a height change is requested, the LEVELING SYSTEM UNAVAILABLE message will display in the driver information center.

Suspension Lowered for Stability

If a malfunction in the electronic stability control system occurs, the air suspension lowers the vehicle at higher speeds to provide increased stability. The driver information center may display a VEHICLE LOWERING FOR STABILITY message.

Excessive Vehicle Loading

If the air suspension detects excessive vehicle loading, ride height is limited to Normal Height mode.

Air Suspension Service

If the driver information center displays the SERVICE LEVELING SYSTEM message, the owner should be advised to bring the vehicle to an authorized dealer immediately.

Electronic Suspension Control System

The electronic suspension control system individually controls the damping force of four shock absorbers in order to keep the vehicle's body as steady as possible. Changes of the damping forces take milliseconds. Suspension characteristics can be changed at any time by activating the sport mode or tour mode.

The electronic suspension control system consists of the following major components:

- suspension control module
- four corner vertical accelerometers
- four shock absorber actuators, which are integrated within the shock absorbers

The suspension control module controls the damping forces according to the following factors:

- vehicle speed
- steering wheel position
- engine torque
- brake pressure

The suspension control module evaluates these inputs to control the shock absorbers separately, providing an enhanced ride and comfort level over the widest possible range of operating conditions.

Suspension Control Module

The suspension control module controls the system functions and detects failures. The suspension control module receives serial data input information from the four suspension vertical accelerometers that are directly connected to the module and by other systems. The suspension control module commands variable levels of current to each shock absorber actuator.

Suspension Vertical Accelerometers

The vertical accelerometers measure the change in velocity, or rate of suspension movement. The suspension control module can adjust the suspension damping based on the vertical accelerometer's input.

The suspension control module supplies a common 5 volt reference and a ground circuit to each of the four corner vertical accelerometers. The accelerometers supply a signal of 0.3–4.7 volts to the suspension control module.

Shock Absorber Actuators

The shock absorber actuators are integrated within the shock absorbers. The electronic suspension control system uses a proportional valve that is located in the external bypass of the displacement module.

Adjustment is performed by current control. The current range is 0–5 amps. The actuators respond to commands of the suspension control module within milliseconds.

Driver Information Center Message

The electronic suspension control system uses the instrument cluster for the display functions. When the suspension control module detects a fault that sets a DTC, it sends a message on the serial data line to the instrument cluster, which will display the SERVICE SUSPENSION SYSTEM message.

The suspension control module has the ability to store DTCs as current or history codes. Most electronic suspension control system malfunctions will display a message in the instrument cluster and set a DTC. As long as the DTC is present, the message will be displayed.

Actions taken when a malfunction is detected remain until the ignition is turned OFF, even if the malfunction is not present anymore.

If a malfunction is no longer present, the DTC is stored as a history code. After 40 consecutive malfunction-free ignition cycles the DTC is erased.

Wheel and Tire Features

Various wheel and tire combinations are available for the 2021 Cadillac Escalade. All vehicles include a spare tire and wheel changing tools mounted in a well under the rear cargo compartment.

Tire Pressure Monitoring System with Tire Fill Alert

The tire pressure monitoring system warns the driver when a significant loss or gain of tire pressure occurs in any of the four tires. The driver can choose to display individual tire pressures and their locations on the driver information center.

The tire pressure monitoring system uses the Body Control Module (BCM), remote control door lock receiver, driver information center, instrument panel cluster, a Radio Frequency (RF) transmitting pressure sensor in each wheel/tire assembly, and the serial data circuit to perform the system functions. Each sensor has an internal power supply.

The tire pressure monitoring system also features a tire fill alert, with visual and audible alerts (light flashes and horn chirps). The alerts assist inflates an underinflated tire to the recommended tire pressure without the need to check a gauge or the instrument panel. Tire fill alert only functions once the tire pressure is low enough to trigger the Malfunction Indicator Lamp (MIL) on the dashboard. When the driver starts filling the underinflated tire, the corner lamp nearest to that tire will begin to flash. When the recommended pressure is reached, the horn sounds once and the turn signal lamps stop flashing and briefly turn solid. If the tire is overinflated by more than 35 kPa (5 psi), the horn will sound multiple times and the turn signal lamp will continue to flash for several seconds after filling stops. To release and correct the pressure, while the turn signal lamp is still flashing, briefly press the center of the valve stem. When the recommended pressure is reached, the horn sounds once.

If the BCM detects a low tire pressure condition or a malfunction in the system, it will send a serial data message to the instrument cluster requesting the appropriate tire pressure monitor indicator to illuminate as well as the appropriate data message to display on the driver information center, if equipped. Both the indicator icon and driver information center message can be cleared by adjusting the tire pressures to the recommended pressures and driving the vehicle above 40 km/h (25 MPH) for at least 2 minutes.

Service Considerations

If power is disconnected from the BCM, or if the vehicle battery is disconnected, each tire pressure monitor sensor's identification is retained, but all tire pressure information is lost. Under these circumstances, the BCM cannot assume that the tire pressures were maintained over an unknown period. The driver information center displays all dashes and the scan tool indicates a default tire pressure value of 220 kPa (32 PSI) for each tire. Driving the vehicle above 40 km/h (25 MPH) for at least 2 minutes activates the sensors and sends the correct tire pressures to the driver information center. The tire pressure monitor diagnostic/sensor activation tool, or equivalent, may also activate the tire pressure sensors.

The BCM has the ability to detect malfunctions within the tire pressure monitor system. In the event a DTC is set, the tire pressure monitor indicator icon on the instrument cluster flashes for 1 minute and remains illuminated for the remainder of the key cycle. After the instrument cluster bulb check has been completed, the

indicator flashes again for 1 minute and remains illuminated if the DTC remains current. Any malfunction detected causes the driver information center to display a SERVICE TIRE PRESSURE MONITOR SYSTEM message.

Tire Pressure Monitoring System Learn Procedure

The tire pressure monitor sensor learn procedure must be performed after every tire rotation, BCM replacement, or tire pressure sensor replacement.

Tire Pressure Monitor Learn Procedure Steps

The tire pressure monitor sensor and Radio Frequency (RF) diagnostic tool allow the tire pressure sensors to be learned without transmitting RF data between the tire pressure sensors and the vehicle. When using the diagnostic tool, each tire pressure sensor identification is learned to the diagnostic tool and stored internally. The diagnostic tool connects to the vehicle DLC using the OBD2 interface module, which is part of the diagnostic tool kit. Next, the stored tire pressure sensor information is loaded into the BCM to learn the tire pressure sensors to prevent the vehicle from learning errant nearby tire pressure sensor information from other vehicles in the service facility, especially if the tire pressure sensor batteries are low. This is the new GM recommended method to learn tire pressure sensors.

Steering

Overview

The 2021 Cadillac Escalade features electric rack-and-pinion steering with a variable power assist feature tuned to provide less assistance at highway speeds and more assistance for less steering effort when maneuvering at low speeds, for example in tight spaces. A heated steering wheel is also available.

Steering System Features

Key features of the variable power assist steering system include the following:

Energy-Absorbing Steering Column

The 2021 Cadillac Escalade uses an energy-absorbing steering column. The energy-absorbing feature, collapsible steering shaft, and breakaway mounting features help reduce the chance of injury to the driver in the event of an accident.

Steering Column Lock

The steering column lock module controls the steering wheel theft deterrent lock function by locking the column electronically. When a valid key is used to start the vehicle, the Body Control Module (BCM) recognizes this and sends an encrypted password to the steering column lock module. The steering column lock module then compares its own stored password to the encrypted password sent by the BCM. If the data matches, the steering column will be unlocked.

In order for the steering column to lock, the steering column lock module must receive three inputs:

1. The BCM power mode is off.
2. The vehicle is stationary based on zero speed reported from all Antilock Braking System (ABS) wheel speed sensors.
3. The driver or passenger door is opened as reported by the BCM.

The steering column lock module monitors the column lock system; if a malfunction is detected, a Diagnostic Trouble Codes (DTCs) is set. In addition, the driver information center displays the SERVICE COLUMN LOCK NOW message.

Belt-Driven Electric Power Steering System

The belt-driven electric power steering system consists of the following components:

Drive Belt and Ball Nut Mechanism

The belt-driven electric power assist steering system reduces the amount of effort needed to steer the vehicle. The power steering control module and motor attach to the base of the steering gear housing. The motor applies power assist through the belt drive and a ball nut mechanism. The ball nut mechanism translates the rotational movement of the drive belt system to lateral movement of the steering gear.

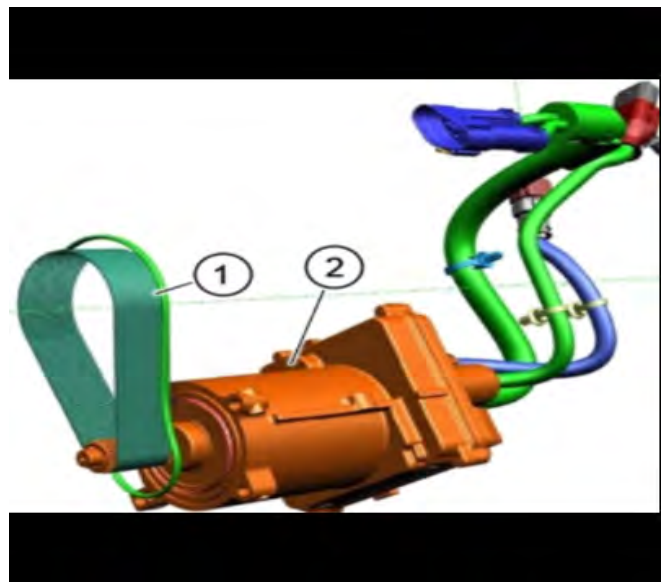

5619594

1. Drive Belt
2. Power Steering Motor

Drive Belt and Power Steering Motor

Power Steering Motor

The power steering motor is a permanent magnet motor that is used to provide steering assist. The motor is powered by a 12 V, three-phase Alternating Current (AC). The electric power steering control module controls the Pulse Width Modulated (PWM) motor drive circuit to drive the three-phase motor.

Power Steering Control Module

The power steering control module uses input from the torque sensor, motor rotational sensor, battery voltage circuit, and high speed CAN 1 serial data circuit to determine the level of motor assist needed. Vehicle speed and engine speed from the high speed CAN 1 serial data circuit are also used to adjust the amount of steering assist needed to steer the vehicle. At low speeds, more assist is provided for easy turning during parking maneuvers. At higher speeds, less assist is provided for improved road feel and directional stability.

The power steering control module calculates the power steering motor temperature based on time and commanded current sent to the power steering motor. The power steering control module may reduce the amount of current commanded to the power steering motor when the calculated temperature parameter is exceeded. As the current is reduced, the amount of steering assist provided is also reduced.

Torque Sensor

The torque sensor is attached to the steering gear housing, near the input shaft of the rack and pinion steering gear. It communicates the driver's steering intent to the electric power steering module. The electric power steering module uses torque sensor information to determine the level of assist provided by the electric power steering motor. It attaches to the power steering motor via the torque sensor wiring harness connector.

Steering Gear

The power steering control module and motor are attached to the base of the steering gear housing. The power steering control module calculates the amount of power assist supplied by the motor through the drive belt and ball nut mechanism to the steering rack.

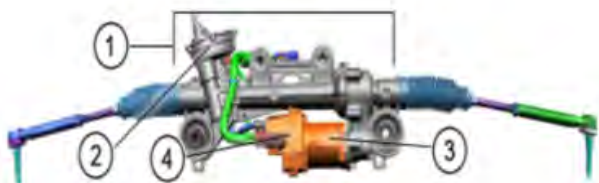

5619595

1. Steering Gear
2. Torque Sensor
3. Power Steering Motor
4. Power Steering Control Module

Power Assist Electronic Steering System

Service Considerations

Any malfunction detected that disables steering assist displays the SERVICE POWER STEERING message on the driver information center. Additionally, the power steering control module calculates an internal system temperature, which is used to protect the power steering system from damage caused by excessive temperatures. When the calculated temperature exceeds a pre-determined threshold, the current command to the power steering motor reduces. The result of the reduction in current is a temporary reduction of power assist. Full assist returns once the calculated temperature drops below the pre-determined threshold. This normal condition does not require repair.

The power steering assist motor and control module are serviced as an assembly. See Service Information (SI) for detailed instructions on replacement and use of special tools for locking the column and for proper drive belt tension.

Power Steering Control Module Calibrations

Centering of the steering angle sensor and software endstop learning might be required after certain service procedures are performed. Some of these procedures are necessary after replacement of the steering gear, steering column, power steering assist motor/module, inner and/or outer tie rods.

Software Endstop Learning

The software endstops are learned automatically and do not require any additional procedures.

PDI Special Instructions

Interior - "Transport Mode On" may display on the DIC or the red battery light may flash. To turn the mode off, start the engine, activate hazard flashers, press brake pedal and turn the ignition key to the crank position for 15 seconds.



5627457

Interior - To use the 110V A/C power outlet, **at each new ignition cycle**, push the 100V A/C power button to enable. The 110V power button (shown circled above) is located to the left of the steering wheel.

Interior - Ensure the hands-free liftgate is set to "Open and Close" under setting in the infotainment.

Exterior - Enable the function of the running boards to deploy, through the Settings icon on the Home Page of the infotainment display. (Vehicle, Running Boards, Automatic Running Boards; - Deploy Running Boards). Open any door and confirm the running board on that side of the vehicle deploys.

Infotainment - If vehicle has RPO IOT (Navigation), ensure that the Nav SD card that is located beneath the USB hub in the armrest console is inserted correctly, and is functional.

New Special Tools for 2021 Full-Size SUV's (U.S. Launch)*

Tool Name	Tool Number	Availability	Divisions	
Installer, Pinion Seal and Side Bearing	DT-52896	Shipped as Essential	Cadillac, Chevrolet, GMC	
Replacer, Pinion Bearing Cup	DT-52898	Available through LTP (Loan Tool Program) only	Cadillac, Chevrolet, GMC	
Replacer, RDM Mount Bushing	DT-52899	Available through LTP (Loan Tool Program) only	Cadillac, Chevrolet, GMC	
Spreader, RDM Rear Cover	DT-52900	Available through LTP (Loan Tool Program) only	Cadillac, Chevrolet, GMC	
Bridge, RDM Side Bearing Cap	DT-52901	Available through LTP (Loan Tool Program) only	Cadillac, Chevrolet, GMC	
Fixture, RDM Rotating	DT-52902	Available through LTP (Loan Tool Program) only	Cadillac, Chevrolet, GMC	
Remover, Axle Flange and Shaft	DT-52903	Shipped as Essential	Cadillac, Chevrolet, GMC	
Installer, Pinion Seal	DT-52904	Available through LTP (Loan Tool Program) only	Cadillac, GMC	(Luxury model)
Installer, RH Output Seal	DT-52905	Available through LTP (Loan Tool Program) only	Cadillac, GMC	(Luxury model)
Installer, LH Output Seal	DT-52906	Available through LTP (Loan Tool Program) only	Cadillac, GMC	(Luxury model)

* In Canada, these Special Tools will be Shipped as Essential.

Version Information

Version	1
Modified	Released October 19, 2020

GM bulletins are intended for use by professional technicians, NOT a "do-it-yourselfer". They are written to inform these technicians of conditions that may occur on some vehicles, or to provide information that could assist in the proper service of a vehicle. Properly trained technicians have the equipment, tools, safety instructions, and know-how to do a job properly and safely. If a condition is described, DO NOT assume that the bulletin applies to your vehicle, or that your vehicle will have that condition. See your GM dealer for information on whether your vehicle may benefit from the information.



WE SUPPORT VOLUNTARY
TECHNICIAN
CERTIFICATION