



S-Series™
BACKED BY McNEILUS

Technical Service Bulletin

2.0 Hydraulic Oil Filter and Oil Specification

Date: October 27, 2020
Bulletin Name: FDM-TSB-001
Model: Oshkosh S-Series
Units Affected: SN 788728 - 802007

Purpose:

This bulletin provides instruction and information on required vehicle hydraulic system updates that address performance deficiencies in the vehicle's hydraulic system.

- The hydraulic reservoir oil filter assembly was supplied to Oshkosh as a non-conforming part and needs the filter assembly strainer removed.
- Oshkosh engineering has updated the vehicle's hydraulic oil specification to increase hydraulic system performance.

Configuration	Components	Truck Starting Temperature Range	Oil	DIN Standard
As Built/Delivered	Strainer present in hydraulic filter	15° F - 110° F	ISO 46	DIN 51527 Part 3 HLP
Post TSB	Strainer removed from hydraulic filter	5° F - 110° F	ISO 46	DIN 51524 Part 3 HLP
New Oil Needed	Strainer removed and Part 3 HVLP oil	-6° F - 110° F	ISO 46	DIN 51524 Part 3 HVLP

The recommended oil viscosity range for all operating temperatures should be 10 - 2500 cSt.

Failure to complete these required system updates could lead to component failure.

Notice:

- This bulletin should be read and understood in its entirety before performing this procedure.
- All procedures outlined in the bulletin must be performed by skilled service personnel. Refer to the product service manual for descriptions of maintenance procedures.

WARNING

Hydraulic systems are hot. **DO NOT TOUCH!** Serious personal injury may result from hot oil. When you have completed working on the hydraulic systems, thoroughly clean any spilled oil from the equipment. Do not spill any hydraulic fluids on the ground. Clean any hydraulic fluids from your skin as soon as you have completed your maintenance and repairs. Dispose of used oil and filters as required by law.

WARNING

Hydraulic systems operate under high pressure—only experienced persons should attempt repairs or troubleshooting on hydraulic systems.

WARNING

Never remove hydraulic pipes/tubing, fittings, or adapters until all pressure has been relieved from the hydraulic system.

WARNING

All hydraulic pressure must be relieved from the hydraulic system prior to removing any components from the system to prevent oil from spraying or functions and systems from failing.

SAFETY NOTICE

Perform your company's Lockout/Tagout procedure. If your company does not have a Lockout/Tagout procedure, follow OSHA 1910.147 and 1910.146 Confined Space as appropriate.

SAFETY NOTICE

Use appropriate Personal Protective Equipment (PPE) as required by your company.

Tools and Equipment Required:

Customer to supply:

- Torque wrenches (foot pounds and inch pounds)
- Hand Tools
- O-ring Lube
- Hydraulic Oil

Parts Required:

Item	Part Number	Description	Qty.
1	1631200	PARKER FILTER RETROFIT KIT	1

Procedure:

Lockout/Tagout

1. Place unit on a flat surface, block truck tires, and perform your company's Lockout/Tagout procedure. If your company does not have a Lockout/Tagout procedure, follow OSHA 1910.147 and 1910.146 Confined Space as appropriate.
2. The vehicle's BATTERY DISCONNECT switch is located on the left-hand side of the battery box. Use the battery disconnect switch when performing any maintenance so the vehicle cannot accidentally be started.
 - a. Turn the battery disconnect switch (Figure A, Item 1) counterclockwise so the hole on the switch aligns with the hole in the bracket (Figure A, Item 2).
 - b. Install the safety lockout device ring (Figure B, Item 1) through the holes on the battery disconnect switch and the bracket.
 - c. Install a padlock (Figure B, Item 2) onto the safety lockout device ring, lock it, and put the key in your pocket. If more than one person is working on the vehicle, each person must install his or her own padlock.

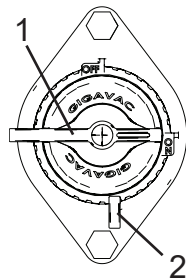

Figure A

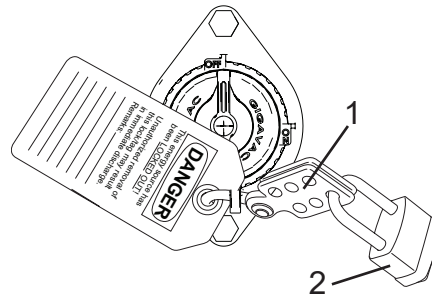

Figure B

Hydraulic System Cleanliness

Today's high system pressures and speeds make clean systems mandatory. A common source of trouble in a system is dirt. Dirt may enter at any time from receipt of the components, to new vehicle delivery or its repair. Scheduled maintenance and good assembly practices will result in prolonged service life of the hydraulic components.

The following practices have been, and always will be, good, sound manufacturing, preventative maintenance, and servicing procedures. They are not costly to institute, but can be highly beneficial to the vehicle user.

Good Housekeeping.

The most obvious and essential point in stressing cleanliness is good housekeeping. Regularly scheduled cleaning, sweeping and washing of assembly and service areas reduce the presence of environmental contamination.

As part of the good housekeeping practices, the location of the service area is very important. This area should be separated from welding, sanding and painting operations. It should also be relatively clear of any outside doors which may be open allowing dust to be blown into the service area.

All hydraulic components should be stored in a clean dry place. Units and components should not be unpacked unless there is an immediate need for them. Stock should be rotated regularly so that the oldest units are used first. The units must be stored with ports plugged. Port protection such as plastic plugs or shipping plugs should not be removed until circuit components are ready for installation.

Fittings and Hoses.

Fittings and hoses which have not been equipped with shipping caps, or have been removed for rework of hydraulic components, must be thoroughly cleaned. Flush fittings or hoses with mineral spirits and air dry. Check forged steel or cast fittings for burrs, foundry sand or casting fins. Failure to remove defects of this nature could result in an early malfunction or component failure. All welded or silver brazed piping should be pickled. It should be neutralized, dried, and oiled with a preservative to prevent rusting. Openings should then be sealed until use at assembly. Mobile Bulletin M-1221-S which covers "Preparation of Pipes, Tubes and Fittings" should be referred to.

Reservoir.

In the operation of hydraulic systems, the reservoir is one of the greatest sources of contamination.

Reservoir Filling. Exercise care to maintain cleanliness when filling the hydraulic system. It is suggested to pump the hydraulic fluid through a 10 micron filter to prevent contamination from entering the system. Vickers OFM series filters are excellent for this type of duty. In addition, the nozzle of the filling hose should be wiped clean with a lint-free paper towel or cloth prior to use.

Hydraulic Reservoir Filter Update

3. Make sure there is no hydraulic pressure in the system.
4. Locate the hydraulic filter assembly on the right-hand side of the truck under the engine cover, see Figure 1.

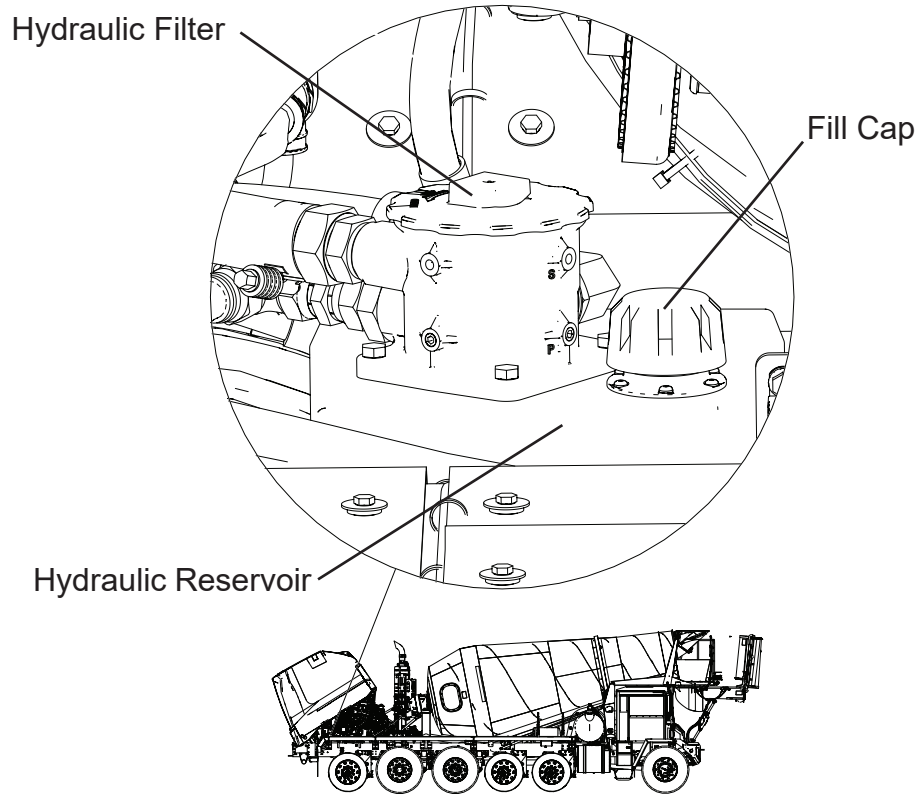

Figure 1 - Hydraulic Filter Location

5. Remove the plastic filter cover from the filter assembly, see Figure 2.



Figure 2 - Hydraulic Filter Cover

6. Locate the strainer mounting screw, see Figure 3.

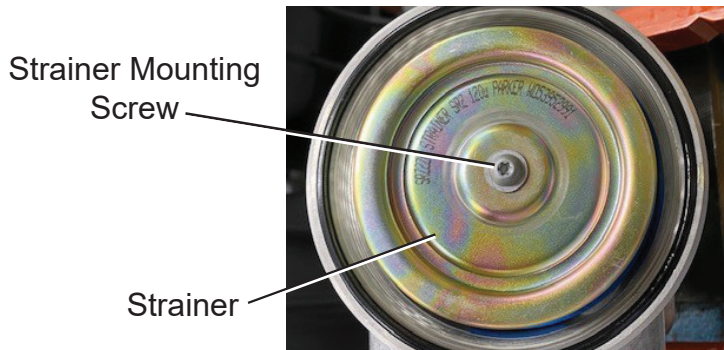

Figure 3 - Strainer Mounting Screw

7. Loosen and remove the strainer mounting screw, see Figure 4.

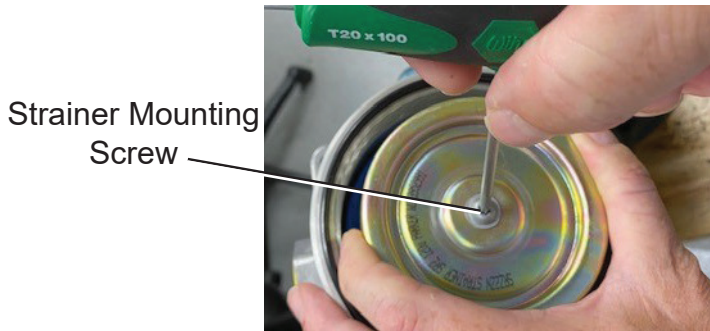

Figure 4 - Strainer Mounting Screw Removal

8. Remove the strainer and spring from the filter assembly and discard, strainer and spring will not be reused. See Figure 5.



Figure 5 - Strainer Removed

9. Install the provided spring. The new spring is marked with a white paint mark on each end. See Figure 6.

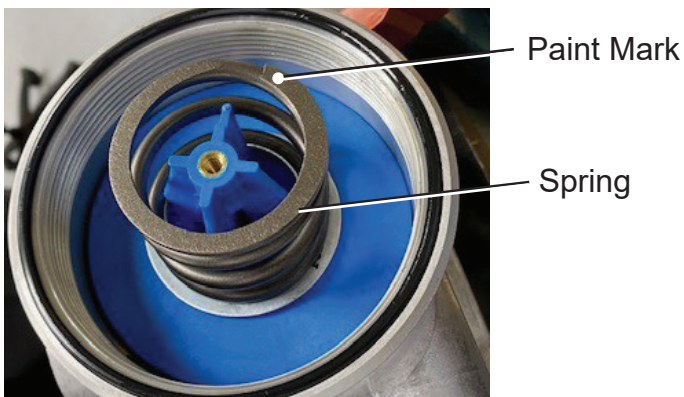

Figure 6 - Spring Installed

10. Install the provided steel cap on top of the spring and secure to filter assembly with provided screw, see Figure 7.

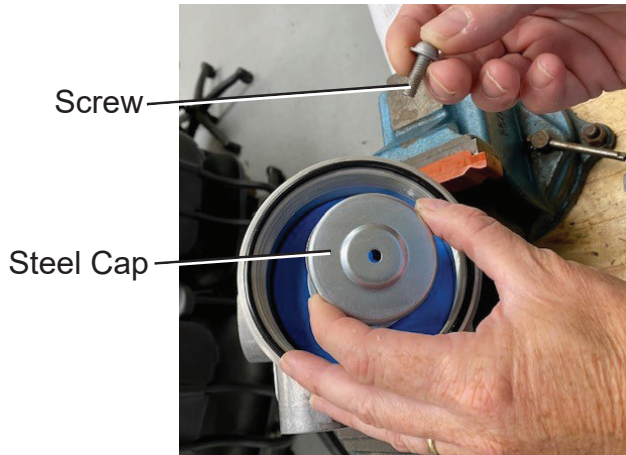

Figure 7 - Steel Cap Installation

11. Final tighten steel cap screw to 40 in. lbs.



Figure 8 - Steel Cap Installation

12. Install filter cover hand tight, see Figure 9.



Figure 9 - Plastic Filter Cover

13. Final tighten filter cover to 28 ft. lbs.

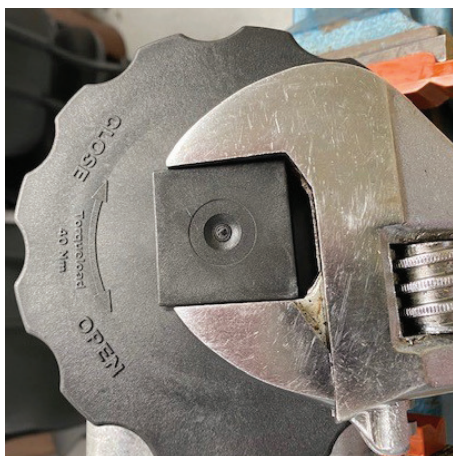

Figure 10 - Plastic Filter Cover

14. With the hydraulic filter suction strainer removed the truck can be started in temperatures down to 5° F without affecting hydraulic system performance. To gain further hydraulic system performance in cold weather the hydraulic oil must be changed according to Table 1. Using a DIN 51524 Part 3 HVLP fluid lowers the minimum starting temperature of the truck to -6° F. Perform Steps 15 - 21 to change the hydraulic oil.

Table 1. Hydraulic Oil Specifications

Configuration	Components	Truck Starting Temperature Range	Oil	DIN Standard
As Built/Delivered	Strainer present in hydraulic filter	15° F - 110° F	ISO 46	DIN 51527 Part 3 HLP
Post TSB	Strainer removed from hydraulic filter	5° F - 110° F	ISO 46	DIN 51524 Part 3 HLP
New Oil Needed	Strainer removed and Part 3 HVLP oil	-6° F - 110° F	ISO 46	DIN 51524 Part 3 HVLP

The recommended oil viscosity range for all operating temperatures should be 10 - 2500 Cst.

Hydraulic Reservoir Oil Change

NOTE

The hydraulic reservoir capacity is approximately 12.5 gallons. Use a drain pan with a capacity of at least 13 gallons when draining the hydraulic reservoir.

15. Place a drain pan below the hydraulic reservoir capable of containing at least 13 gallons.

16. Loosen and remove the 7/8" drain plug from the bottom of the hydraulic reservoir and drain all hydraulic oil from the reservoir, see Figure 11.

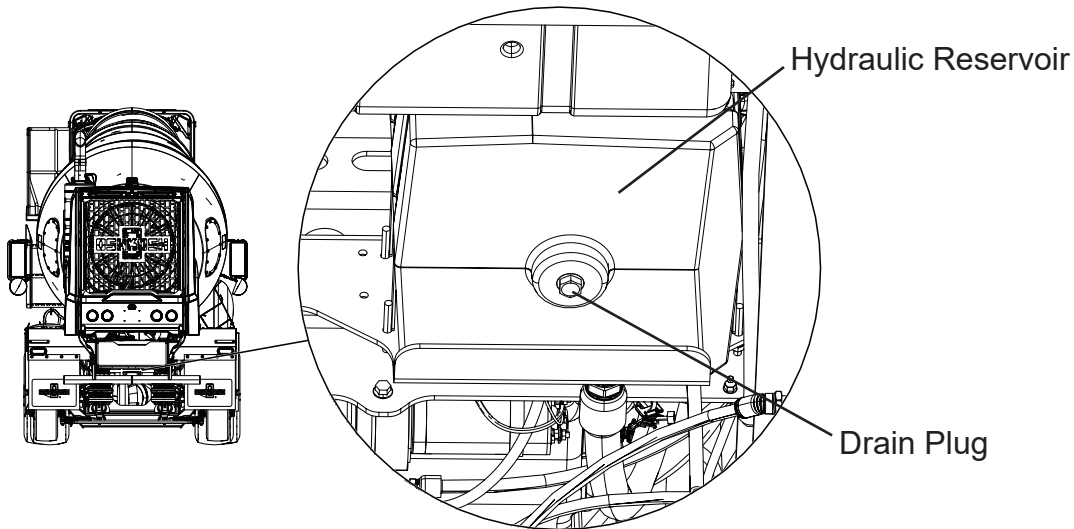

Figure 11 - Hydraulic Reservoir Drain

17. Apply O-ring lube to the drain plug O-ring.
18. Reinstall the 7/8" drain plug in the bottom of the hydraulic reservoir and torque to 27 ft. lbs.
19. Clean the area around the hydraulic reservoir fill cap, see Figure 12.
20. Remove the fill cap and fill the reservoir with new approved hydraulic oil until the level is to the MAX mark. See Table 1 for hydraulic oil specification.
21. Reinstall the reservoir fill cap.

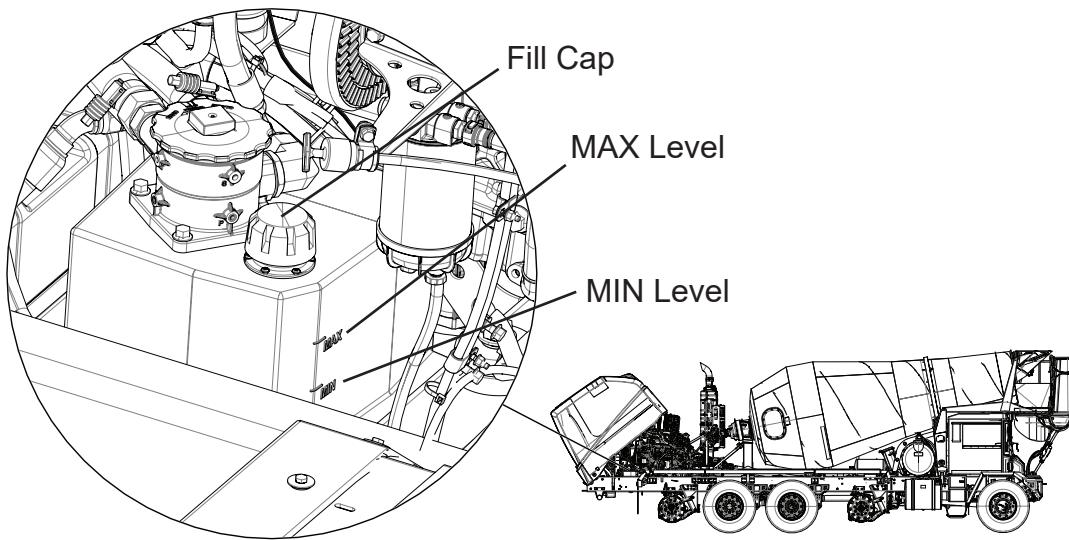

Figure 12 - Hydraulic Reservoir Fill

22. Remove lockout/tag.

Cold Weather Start-Up

The cold weather start-up procedure has been updated and needs to be followed any time the truck is started in ambient temperatures below 10° F or below 20° F. See below for the updated operator manual cold weather start-up information.

Configuration	Truck Starting Temperature Range	Oil	DIN Standard	Cold Start Idle Time
Strainer removed from hydraulic filter	5° F - 110° F	ISO 46	DIN 51524 Part 3 HLP	20° F or less - 10 minutes
Strainer removed and Part 3 HVLP oil	-6° F - 110° F	ISO 46	DIN 51524 Part 3 HVLP	10° F or less - 10 minutes

7.3 Cold Weather Start-Up

CAUTION

Idle the truck for 10 minutes when the ambient temperature is below 10° F or below 20° F. Failure to avoid operating the systems listed in Section 7.3 could lead to hydraulic system component damage.

Truck Starting Temp.	Oil	Cold Start Idle Time
5° F - 110° F	ISO 46 DIN 51524 Part 3 HLP	20° F or less - 10 min.
-6° F - 110° F	ISO 46 DIN 51524 Part 3 HVLP	10° F or less - 10 min.

Starting of the truck in ambient temperatures below 10° F or below 20° F requires the driver avoid the following operations for 10 minutes to allow the truck's hydraulic system oil temperature to rise to an acceptable system operating temperature.

- Do not use high idle or provide any throttle input to engine.
- Do not use drum controls.
- Do not operate chutes.
- Do not operate water pump.
- Do not steer steering wheel.

7.3.1 Block Heater

The block heater is thermostatically controlled and can be plugged in at any time the vehicle is not running.

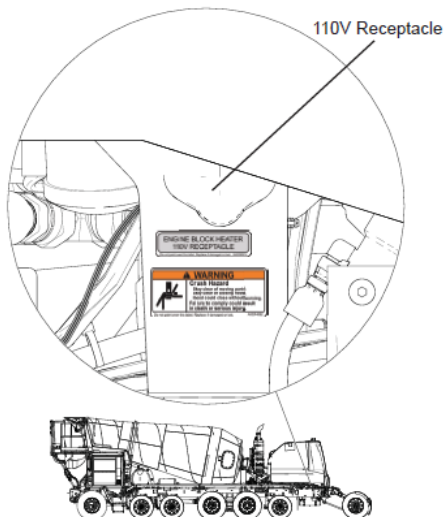

Figure 32 Block Heater

1. Open cover on external receptacle located on the left side radiator support of vehicle.

WARNING

Be sure extension cable is free of moisture. Never remove or bypass grounding prong on extension cable. Failure to comply can result in personnel injury or death by electrocution.

2. Plug extension cable into external 110V receptacle.

CAUTION

Never run engine with coolant heater plugged in. The heater will be damaged if plugged in while engine is running.

3. Remove extension cable before starting vehicle.

Reimbursement of Costs:

Affected units shall be repaired using the customer's own qualified service technicians - at no cost to the owner. The repairs will take approximately 20 minutes to complete and Oshkosh Corporation will reimburse a full hour of labor.

Labor Reimbursement:

In order to receive credit, claims are to be submitted through the normal warranty claim system. Claims must be received within 30 days of the repair. Claims must include the McNeilus serial number of the truck, the customer asset number, and the number of this bulletin.

Parts Reimbursement:

Parts and ground shipping will be reimbursed to the customer. Parts necessary for this repair must be ordered from McNeilus Parts at 888-686-7278.

Claims are to be submitted through the normal warranty claim system. Claims must be received within 30 days of the repair. Claims must include the McNeilus serial number of the truck, the customer asset number, and this bulletin's number.

Contacts:

If you have questions or need further information, please contact a McNeilus National Service Representative at 888-686-7278.

Continuous Improvement:

The change included in this document is part of the McNeilus Continuous Improvement Process.

McNeilus's quality policy is providing customer satisfaction through innovative products, dedicated service, and a constant focus on continuous improvement.



(888) 686-7278

www.streetsmartparts.com