

## QUARANTINE NOTICE

Reference number:	QN-63-1433	Issued: 4 November, 2020
Subject:	Correct Installation of the Front Wiring Harness	
Model(s):	DBX	
VIN Range:	Refer to the separately published list of affected Vehicle Identification Numbers (VINs)	
Applicable to:	All Dealers	
Distribute to:	After Sales Manager Executive Manager Service Manager Sales Manager	Warranty Staff Technician(s) Parts Staff

### Reason for this Quarantine Notice

Aston Martin has found that some DBX vehicles have incorrect installation of the front wiring harness. Do the workshop procedure that follows to correct this problem.

### Workshop Procedure

**Note:** *Illustrations are for aid only. Some variation can occur.*

*Some components illustrated are removed for clarity.*

**Complete all required Parts in order A-B-C-D.**

This workshop procedure has four parts:

- Part A: Inspection
- Part B: Correctly attach the wiring harness to the secondary bulkhead
- Part C: Correctly route the wiring harness
- Part D: Correctly route the wiring harness to the brake booster

**Part A: Inspection**

**Note: Part A must be fully completed.**

1. Remove the right side access panel for the leaf screen. (Refer to Workshop Manual Procedure 31.10.CC)
2. Disconnect the electrical connector. (refer to Figure 1).

**Note: This step only applies to left hand drive vehicles.**

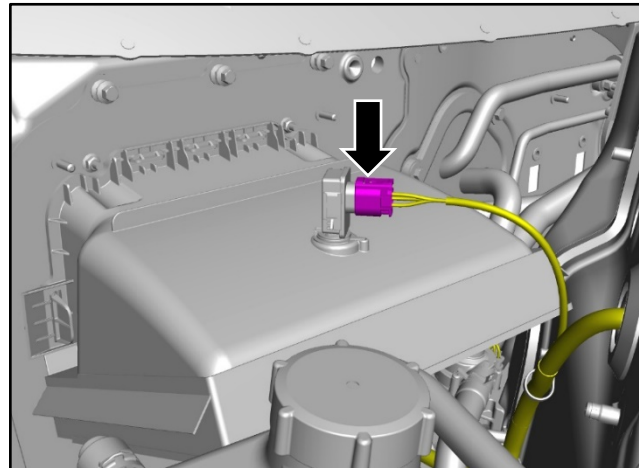

**Figure 1**

3. Release the clips '1' that attach the heater inlet duct securing. Remove the duct from the upper mounts '2'. (refer to Figure 2).

**Note: This step only applies to left hand drive vehicles.**

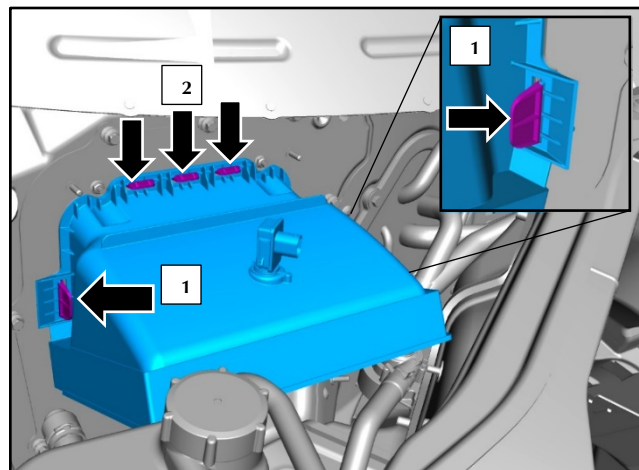

**Figure 2**

4. Examine the wiring harness path around the brake line and make sure that the wiring harness is correctly attached.

**Note: If this wiring harness is incorrectly installed, then you must do Part B: Correctly attach the wiring harness to the secondary bulkhead.**

This image shows the wiring harness installed in the correct position. (refer to Figure 3).

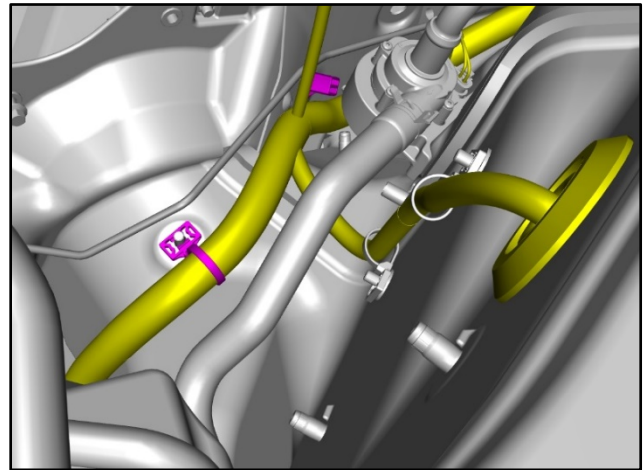

Figure 3

This image shows the wiring harness incorrectly installed (refer to Figure 4).



Figure 4

5. Make sure the wiring harness is correctly installed to the secondary bulkhead.

**Note: If this wiring harness is incorrectly installed, then you must do Part B: Correctly attach the wiring harness to the secondary bulkhead.**

This image shows the wiring harness installed in the correct position. (refer to Figure 5).

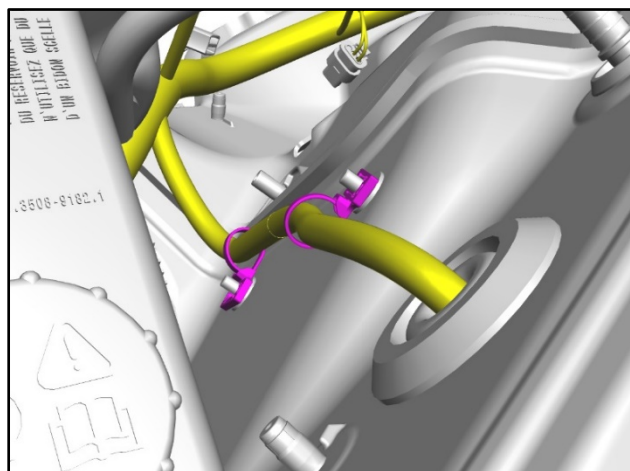

Figure 5

This image shows the wiring harness incorrectly installed. (refer to Figure 6).

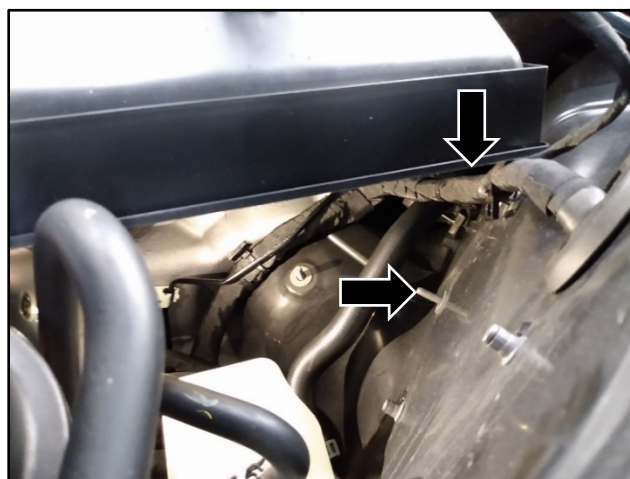
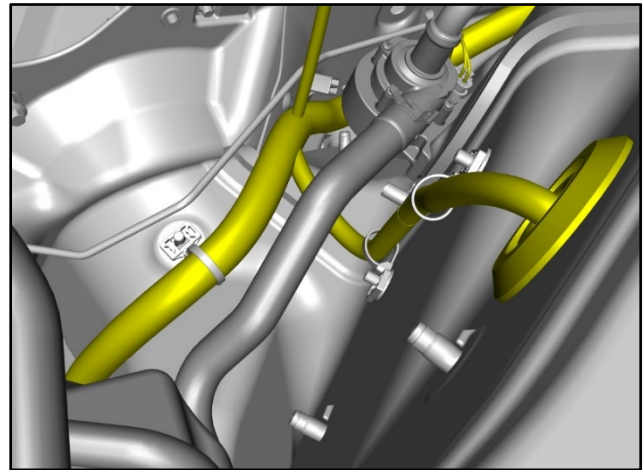

Figure 6

6. Make sure the wiring harness path is installed under the coolant hose.

**Note: If this wiring harness is incorrectly installed, then you must do Part C: Correctly route the wiring harness.**

This image shows the wiring harness path in the correct position under the coolant hose. (refer to Figure 7).



**Figure 7**

This image shows the wiring harness incorrectly installed above the coolant hose. (refer to Figure 8).



**Figure 8**

7. Examine the wiring harness path around the brake lines.

**Notes: If this wiring harness is incorrectly installed, then you must do Part D: Correctly route the wiring harness to the brake booster.**

**This step only applies to right hand drive vehicles.**

This image shows the wiring harness path in the correct position. (refer to Figure 9).

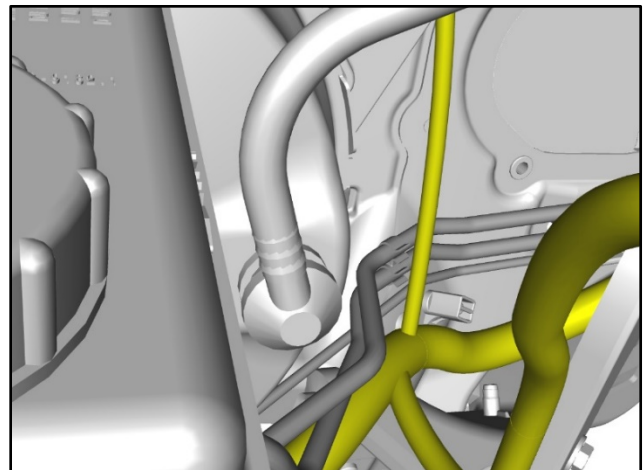

Figure 9

This image shows the wiring harness incorrectly installed behind the brake lines. (refer to Figure 10).



Figure 10

**Note: If Part B, Part C or Part D is to be completed, do not complete step 8 thru step 10 of Part A.**

8. Install the heater inlet duct. (refer to Figure 11).

**Note: This step only applies to left hand drive vehicles.**

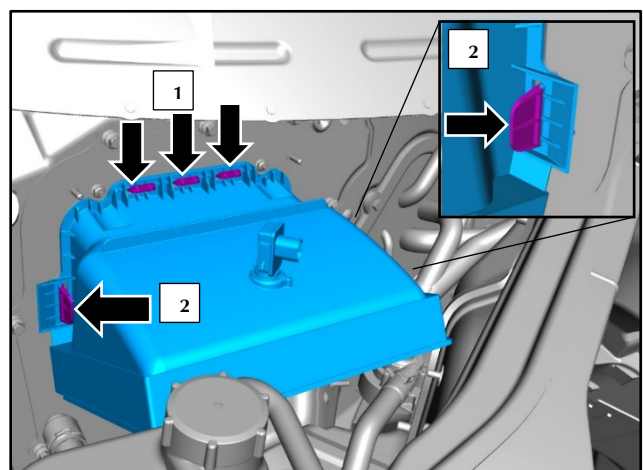
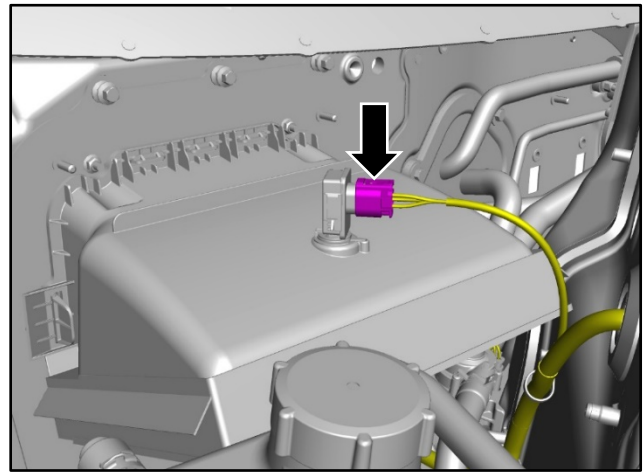

Figure 11

9. Connect the electrical connector. (refer to Figure 12).

**Note:** *This step only applies to left hand drive vehicles.*



**Figure 12**

10. Install the right side access panel for the leaf screen. (Refer to Workshop Manual Procedure 31.10.CC)

**Part B: Correctly attach the wiring harness to the secondary bulkhead**

1. Make sure that the wiring harness is not caught.
2. Using an endoscope where necessary, examine the wiring harness for any damage.
3. Using an endoscope where necessary, examine the brake line for any damage.

**Note: For right hand drive vehicles, pay extra attention to the area surrounding the brake master cylinder and vacuum booster.**

4. Make sure that the brake lines are installed correctly (refer to Figure 13).

**Note: Right hand drive vehicle illustrated. Left hand drive vehicle is similar.**

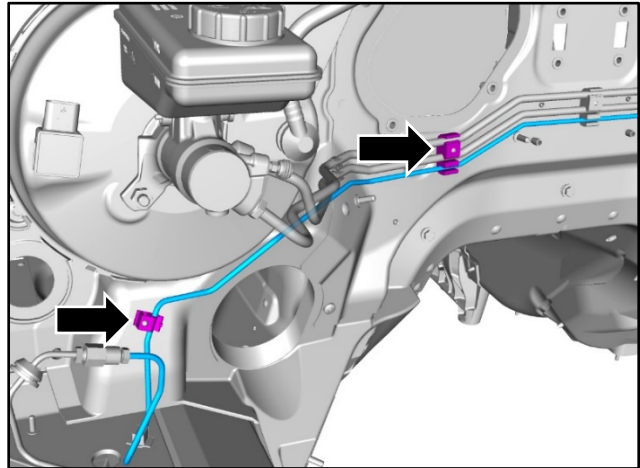

**Figure 13**

5. Install the wiring harness (refer to Figure 14).

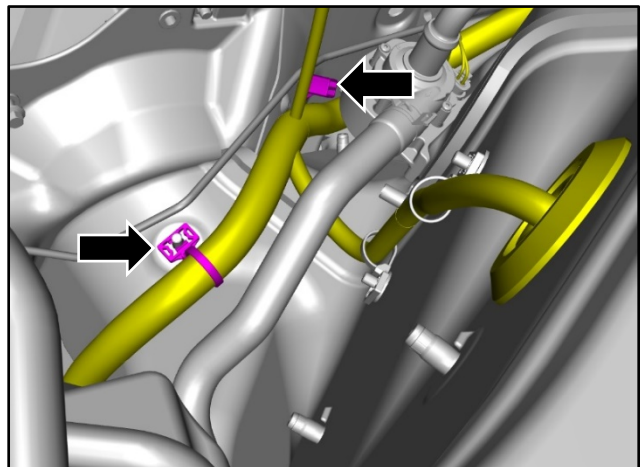

**Figure 14**

**Note: If Part C is to be completed, do not complete step 6 thru step 9 of Part B.**

6. Install the wiring harness (refer to Figure 15).

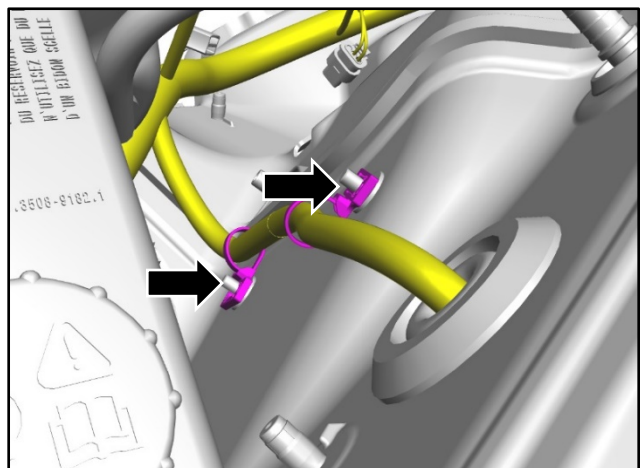
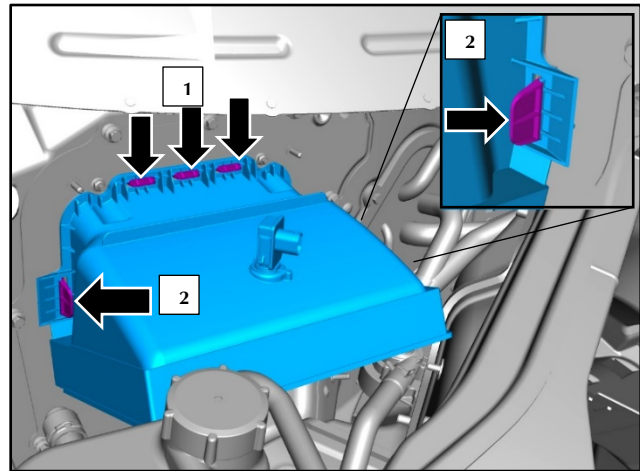

**Figure 15**

**Note: If Part D is to be completed, do not complete step 7 thru step 9 of Part B.**

7. Install the heater inlet duct (refer to Figure 16).

**Note: This step only applies to left hand drive vehicles.**



**Figure 16**

8. Connect the electrical connector (refer to Figure 17).

**Note: This step only applies to left hand drive vehicles.**

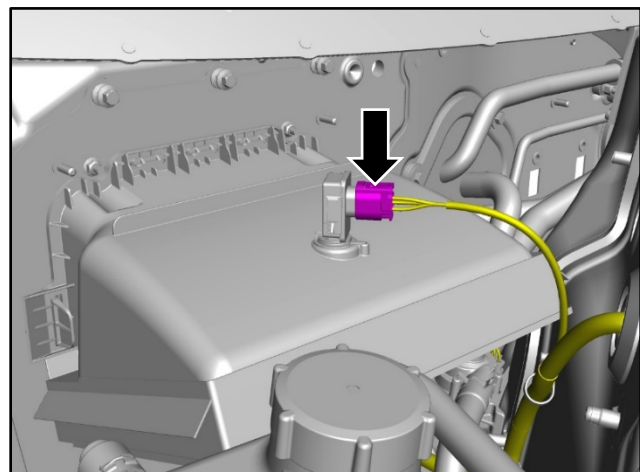
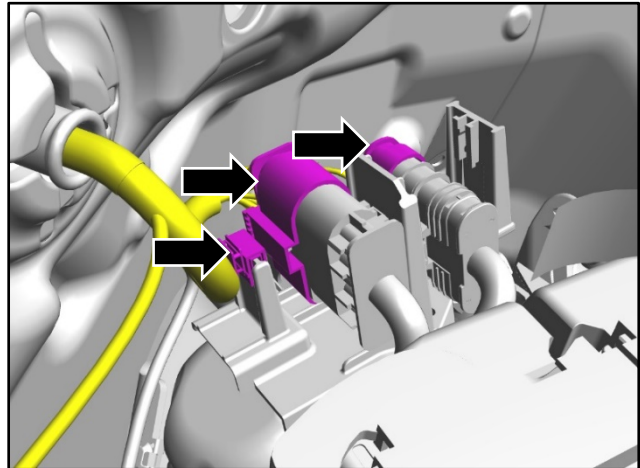

**Figure 17**

9. Install the right side access panel for the leaf screen. (Refer to Workshop Manual Procedure 31.10.CC)

**Part C: Correctly route the wiring harness**

1. Disconnect the battery (Refer to Workshop Manual Procedure 63.01.AK)
2. Remove the engine cover assembly (Refer to Workshop Manual Procedure 03.12.BK)
3. Disconnect the two electrical connectors and release the clip for the wiring harness (refer to Figure 18).



**Figure 18**

4. Disconnect the electrical connector (refer to Figure 19).

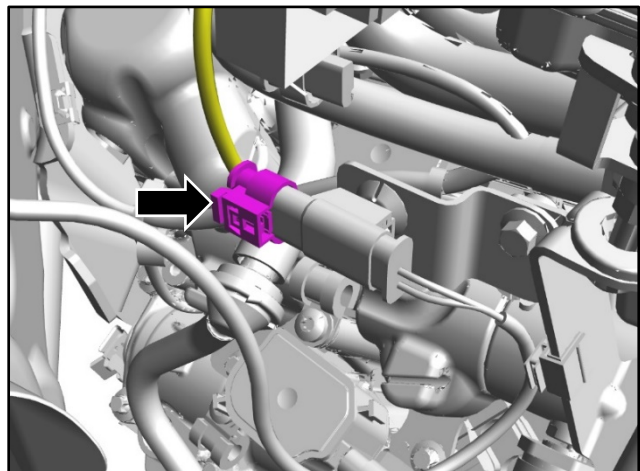

**Figure 19**

5. Release the two clips that attach the wiring harness to the engine (refer to Figure 20).

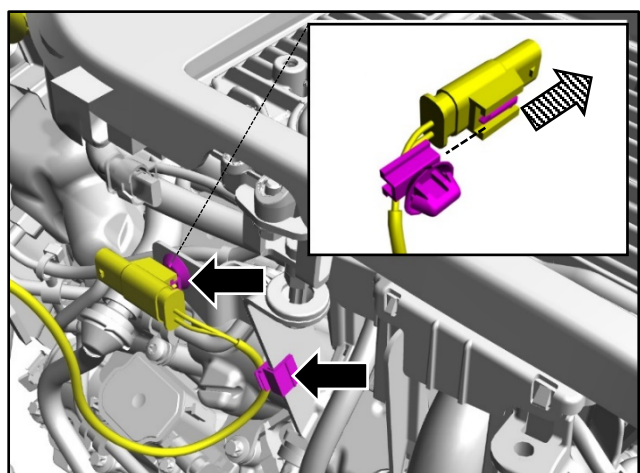

**Figure 20**

6. Release the two clips for the wiring harness (refer to Figure 21).

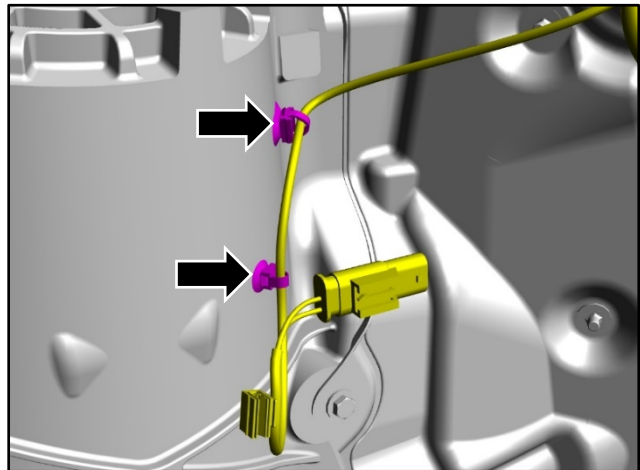

Figure 21

7. Release the rubber grommet (refer to Figure 22).

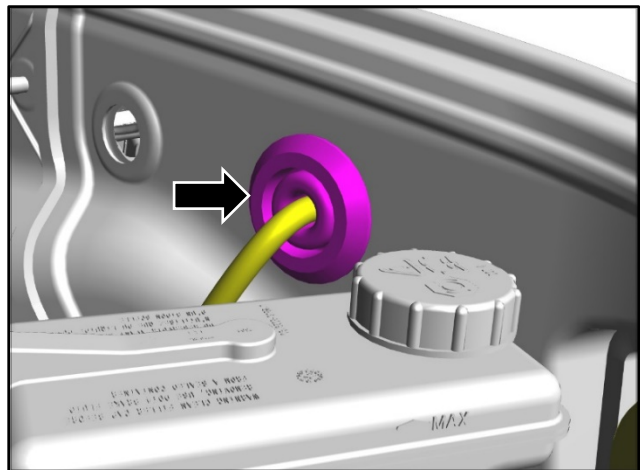

Figure 22

8. Route the harness through the secondary bulkhead from the engine bay.
9. Using an endoscope where necessary, examine the wiring harness for any damage.
10. Using an endoscope where necessary, examine the brake line for any damage.

**Notes: If this step was done in Part B, then go to the next step.**

**For right hand drive vehicles, pay extra attention to the area surrounding the brake master cylinder and vacuum booster.**

11. Check the security of the brake line and brake line mountings (refer to Figure 23).

**Note: If this step was done in Part B, then go to the next step.**

**Right hand drive vehicle illustrated. Left hand drive vehicle is similar.**

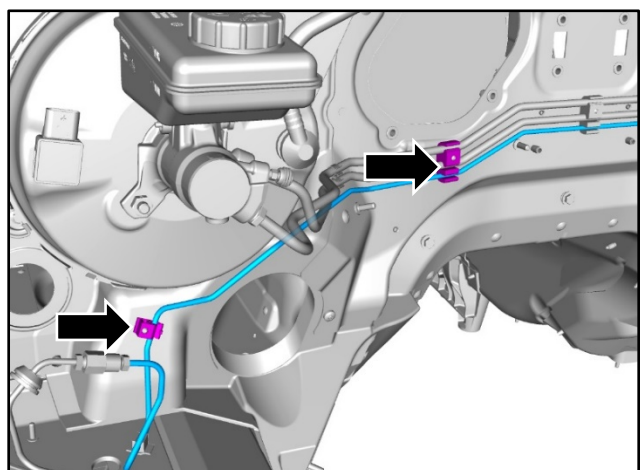

Figure 23

12. Install the wiring harness under the coolant hose (refer to Figure 24).

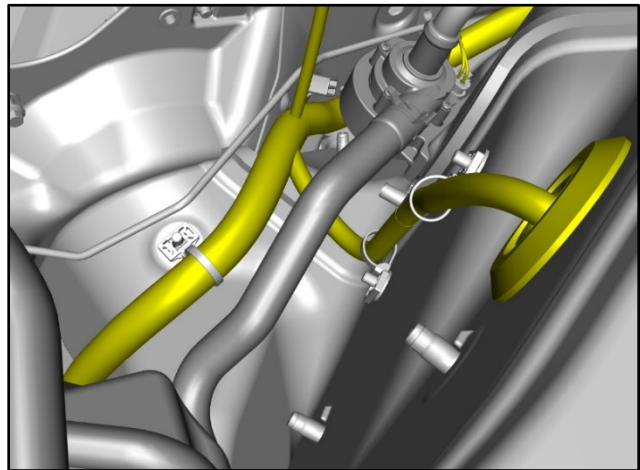

Figure 24

13. Route the harness through the secondary bulkhead to the engine bay.
14. Install the wiring harness (refer to Figure 25).

**Note:** *Right hand drive vehicle illustrated. Left hand drive vehicle is similar.*

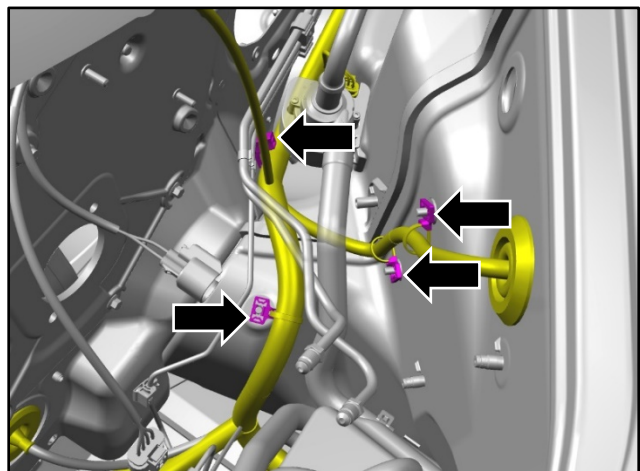

Figure 25

15. Install the rubber grommet (refer to Figure 26).

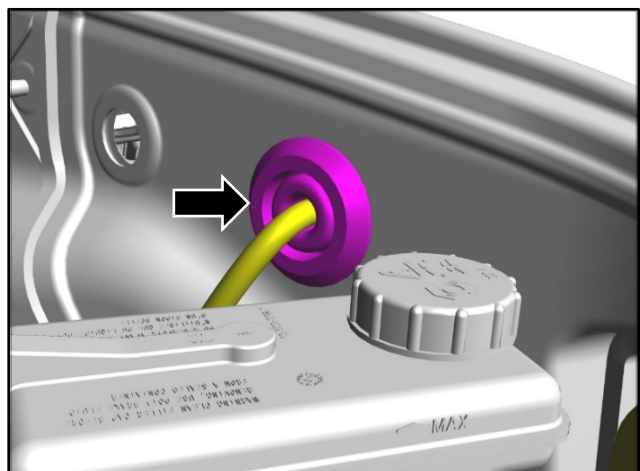

Figure 26

16. Install the two clips for the wiring harness (refer to Figure 27).

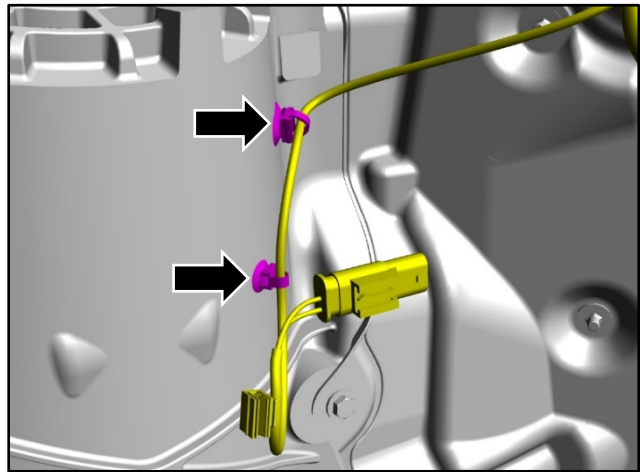

Figure 27

17. Install the two clips that attach the wiring harness to the engine (refer to Figure 28).

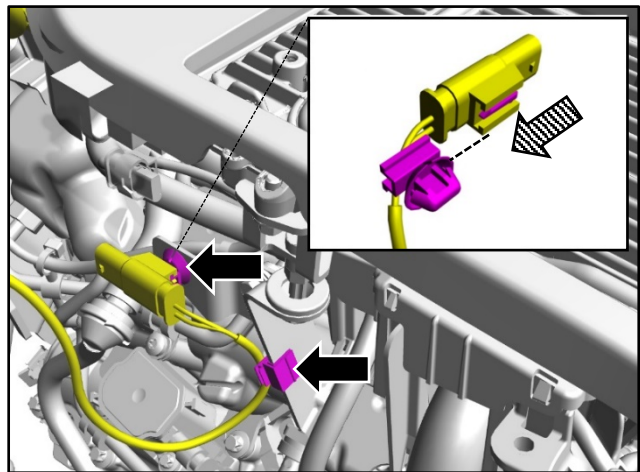

Figure 28

18. Connect the electrical connector (refer to Figure 29).

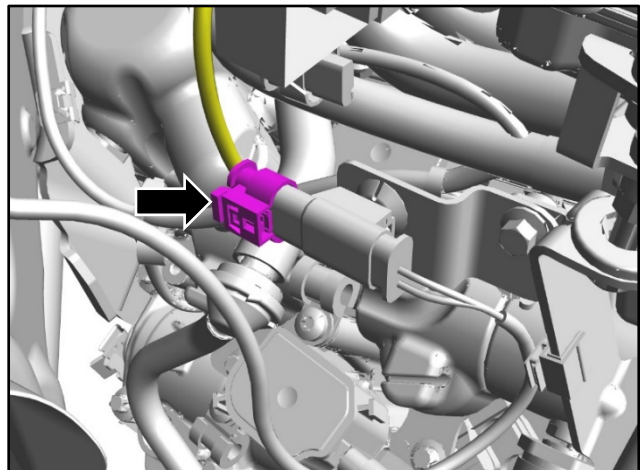

Figure 29

19. Connect the two electrical connectors and install the clip for the wiring harness (refer to Figure 30).

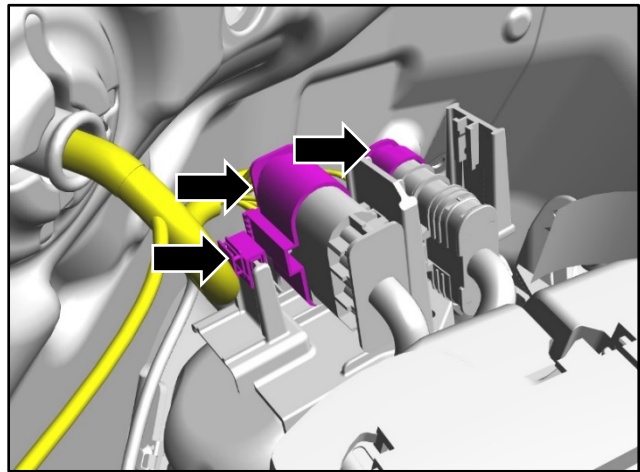

Figure 30

20. Install the engine cover assembly (refer to Workshop Manual Procedure 03.12.BK)

**Note: If Part D is to be completed, do not complete step 21 thru step 24 of Part C.**

21. Install the heater inlet duct (refer to Figure 31).

**Note: This step only applies to left hand drive vehicles.**

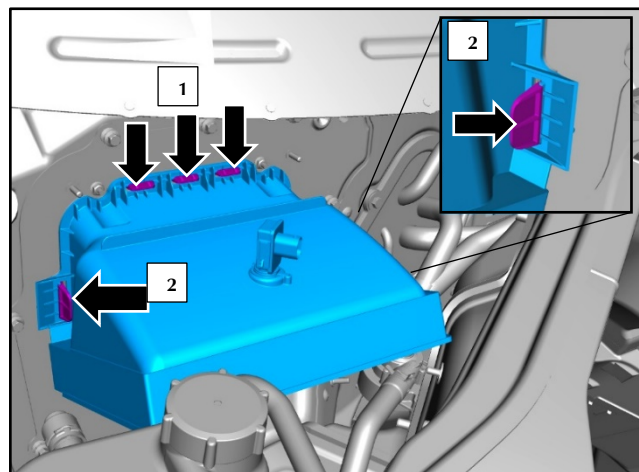

Figure 31

22. Connect the electrical connector. (refer to Figure 32).

**Note: This step only applies to left hand drive vehicles.**

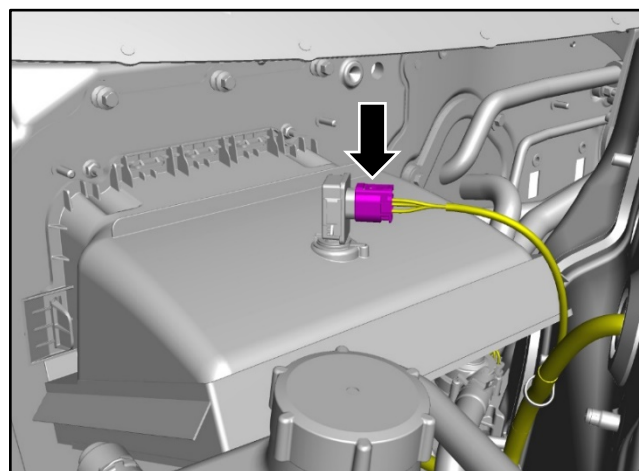

Figure 32

23. Install the right side access panel for the leaf screen. (Refer to Workshop Manual Procedure 31.10.CC)
24. Connect the battery (Refer to Workshop Manual Procedure 63.01.AK)

**Part D: Correctly route the wiring harness to the brake booster**

**Note: Part D is only applies to right hand drive vehicles.**

1. Disconnect the battery (refer to Workshop Manual Procedure 63.01.AK)

**Note: If this step was done in Part C, then go to the next step.**

2. Disconnect the two electrical connectors and release the clip for the wiring harness (refer to Figure 33).

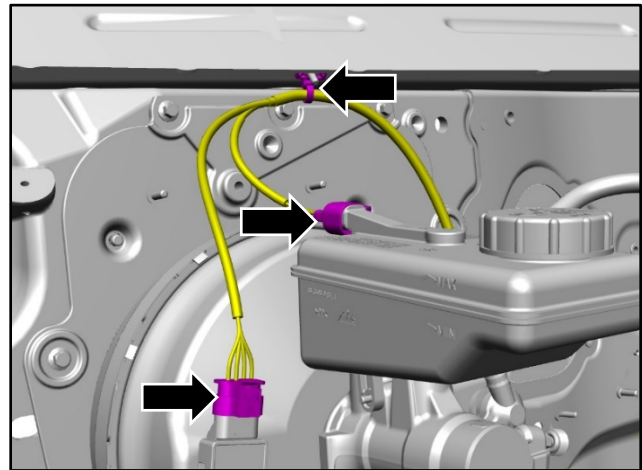

**Figure 33**

3. Route the wiring harness correctly around the brake lines (refer to Figure 34).

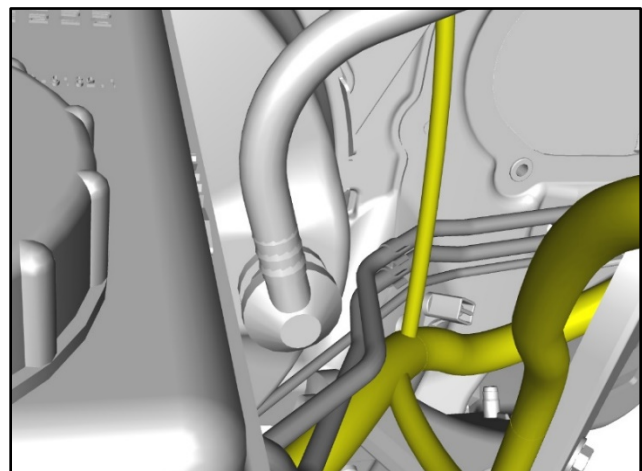

**Figure 34**

4. Using an endoscope where necessary, examine the wiring harness for any damage.
5. Connect the two electrical connectors and install the clip for the wiring harness (refer to Figure 35).

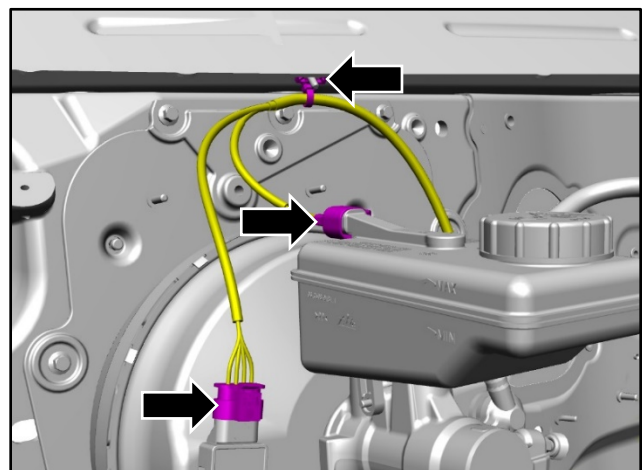

**Figure 35**

6. Connect the battery (Refer to Workshop Manual Procedure 63.01.AK)

7. Install the right side access panel for the leaf screen. (Refer to Workshop Manual Procedure 31.10.CC)

**Warranty Data**

**Procedure and Labour Time**

Description	Left hand drive	Right hand drive	Labour Time	Tier Reference
Part A	X	X	0.1	Tier A
Part A + Part B	X	X	0.2	Tier B
Part A + Part C	X	X	0.8	Tier C
Part A + Part D		X	0.5	Tier D
Part A + Part B + Part C	X	X	0.8	Tier E
Part A + Part B + Part D		X	0.5	Tier F
Part A + Part C + Part D		X	1.0	Tier G
Part A + Part B + Part C + Part D		X	1.1	Tier H

If you have any questions related to this document, please refer to the 'Contact Us' link on this webpage, or contact your local Dealer or After Sales Manager.

The English version of this document is written in Simplified Technical English to ASD-STE100™.