

JTBO0604NAS2

**TECHNICAL BULLETIN**

06 OCT 2020



© Jaguar Land Rover North America, LLC

NOTE: The information in Technical Bulletins is intended for use by trained, professional Technicians with the knowledge, tools, and equipment required to do the job properly and safely. It informs these Technicians of conditions that may occur on some vehicles, or provides information that could assist in proper vehicle service. The procedures should not be performed by 'do-it-yourselfers'. If you are not a Retailer, do not assume that a condition described affects your vehicle. Contact an authorized Jaguar service facility to determine whether this bulletin applies to a specific vehicle.

**INFORMATION**

**This reissue replaces all previous versions. Please destroy all previous versions.**

This bulletin supersedes TSB JTBO0604NAS1/2017 dated 28 NOV 2017, which should either be destroyed or clearly marked to show it is no longer valid (e.g. with a line across the page). Only refer to the electronic version of this Technical Bulletin in TOPIx.

Changes are highlighted in blue

**SECTION:**

501-12

**SUBJECT/CONCERN:**

Creak Noise From The Instrument Panel

**AFFECTED VEHICLE RANGE:**

MODEL:	MODEL YEAR:	VIN:	ASSEMBLY PLANT:
F-PACE (X761)	2017-2018	045068-099999	Solihull

MODEL:	MODEL YEAR:	VIN:	ASSEMBLY PLANT:
F-PACE (X761)	2017	488002-499999	Solihull
F-PACE (X761)	2017-2018	880002-899997	Solihull
F-PACE (X761)	2018-2020	240000-623709	Solihull

---

#### MARKETS:

NORTH AMERICA

---

#### CONDITION SUMMARY:

#### SITUATION:

A creak noise may be evident from the center of the instrument panel.

#### CAUSE:

Contact between body panels on the bulkhead.

#### ACTION:

Follow the instructions below.

---

#### WARRANTY:

##### NOTES:

- Repair procedures are under constant review, and therefore times are subject to change; those quoted here must be taken as guidance only. Use TOPIx to obtain the latest repair time.
- The JLR claims submission system requires the use of causal part numbers. Labor only claims must show the causal part number with a quantity of zero.

DESCRIPTION	SRO	TIME (HOURS)	CONDITION CODE	CAUSAL PART
Front bulkhead - Modification	76.96.64	0.4	07	T4A1726

**NOTE:**

Normal Warranty procedures apply.

**SERVICE INSTRUCTION:****NOTE:**

Right side shown; left side similar.

1.

**NOTE:**

The cowl panel may also be known as the cowl vent screen.

Remove the cowl panel (see TOPlx Workshop Manual section 501-02: Front end panels - Removal and installation - Cowl panel ).

2.

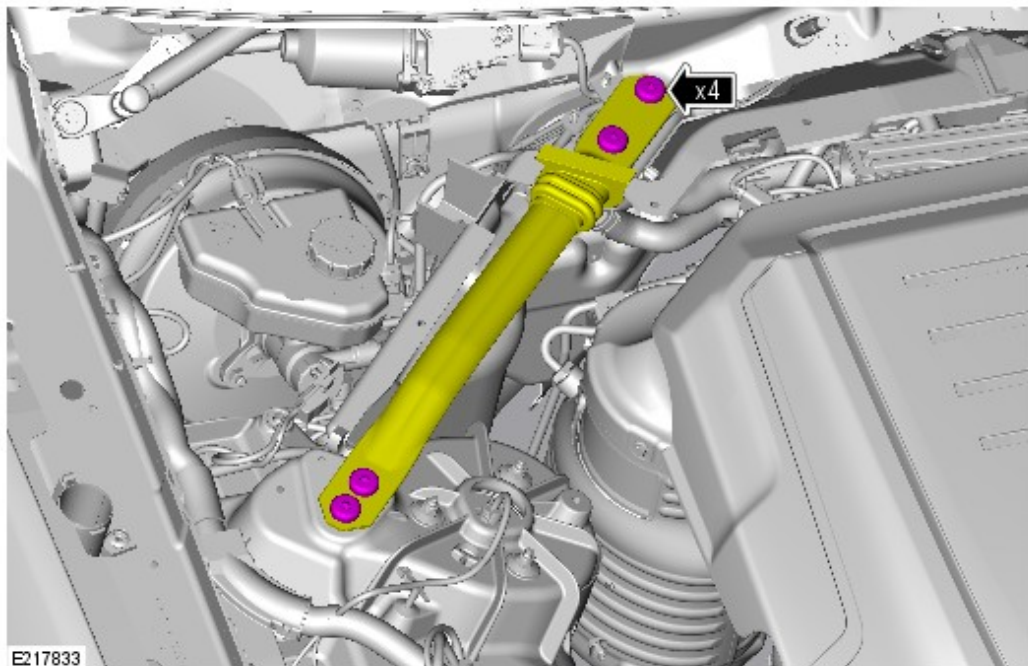

Loosen, but do not fully remove, the support bar retaining bolts.

3.

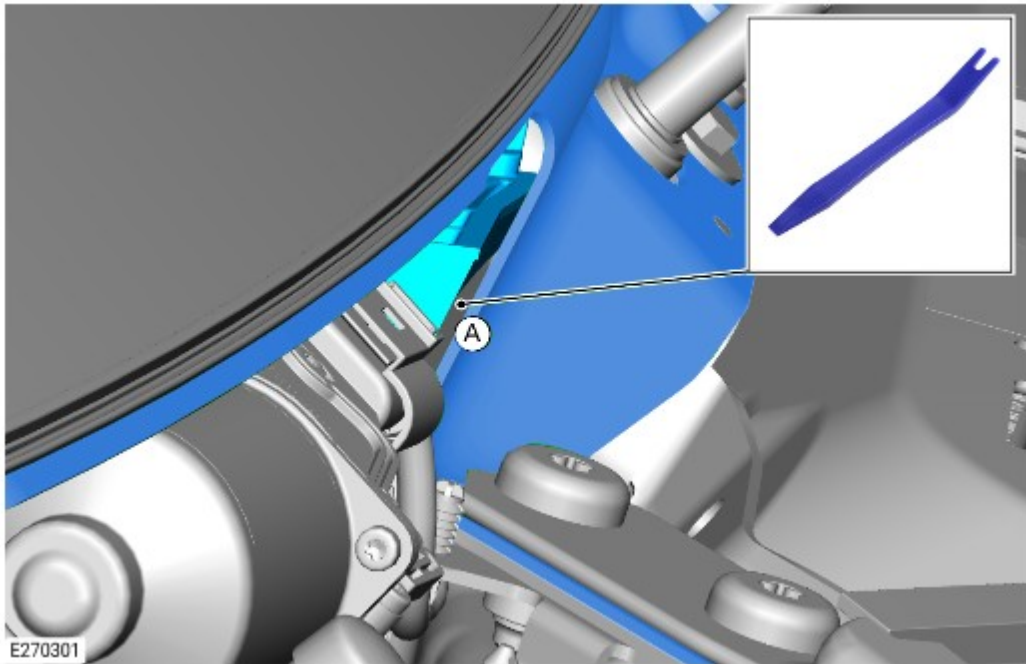

Insert a suitable trim tool between the bulkhead baffle and bulkhead panel **(A)**.

4.

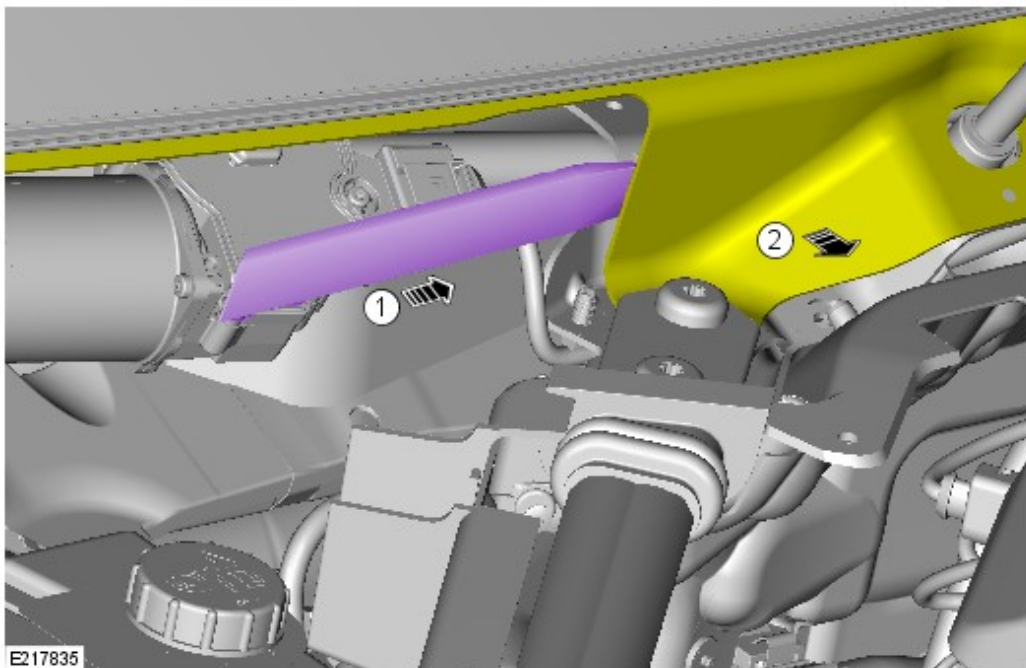

Inserting the suitable trim tool **(1)** between the bulkhead baffle and bulkhead panel will move the bulkhead panel **(2)** forward away from the baffle.

5.

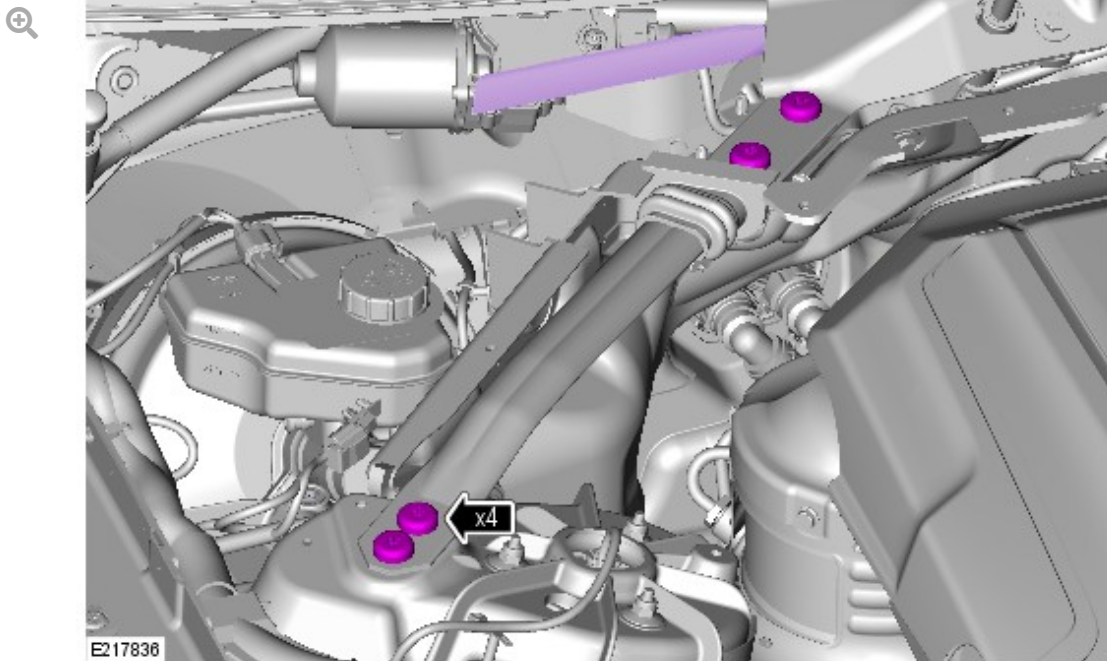

With the trim tool in place, tighten the support bar retaining bolts.

- ■ Torque: **55 Nm**

6.

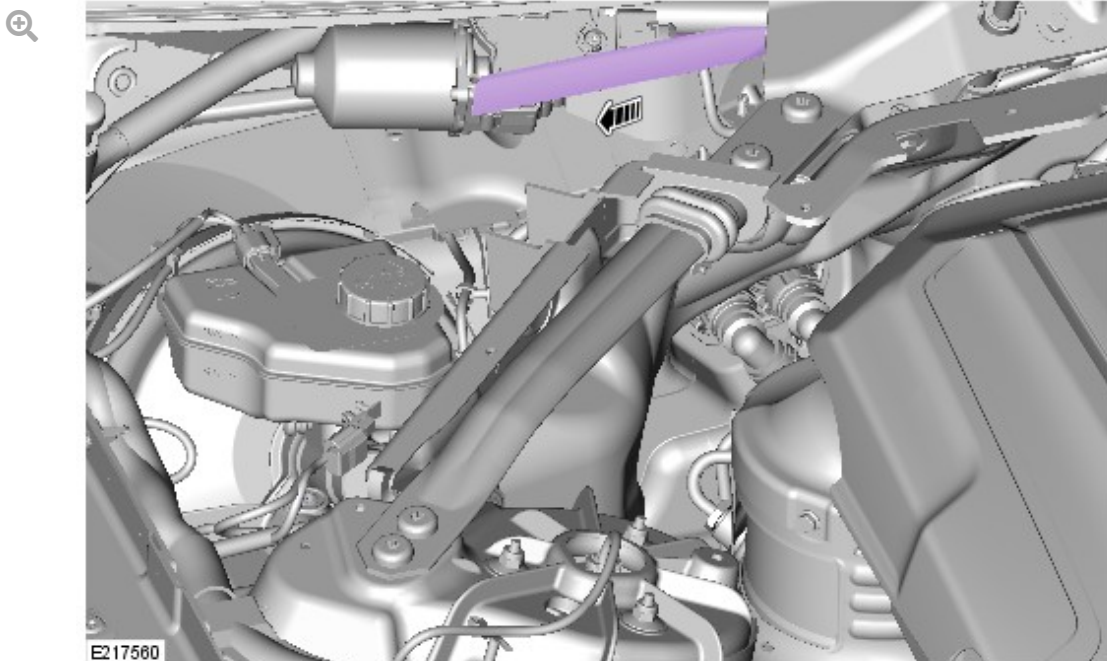

Remove the trim tool.

7. Repeat steps 2 to 6 for the other side of the vehicle.

8.

**NOTE:**

The cowl panel may also be known as the cowl vent screen.

Install the cowl panel (see TOPlx Workshop Manual section 501-02: Front end panels - Removal and installation - Cowl panel).