

Technical product information

Topic	Engine Cooling System - DTC P218100 - V8 Kovomo
Market area	Bentley: worldwide (2WBE)
Brand	Bentley
Transaction No.	2060205/2
Level	EH
Status	Released for publishing
Release date	30-Oct-2020

New customer code

Object of complaint	Complaint type	Position
engine -> cooling, lubrication -> engine coolant temperature control	functionality -> faulty	
engine -> cooling, lubrication -> engine coolant temperature control	functionality -> too slow	
engine -> cooling, lubrication	functionality	
engine -> cooling system	functionality	

New workshop code

Object of complaint	Complaint type	Position
engine -> operation, engine control -> engine control unit	control units, services -> with event log entry	

Vehicle data

Bentayga

Sales types

Type	MY	Brand	Designation	Engine code	Gearbox code	Final drive code
4V14D9	2018	E	SUV KoVOMo BY636 404/V8 8AG	DCUA	RWH	QUT
4V14D9	2019	E	SUV KoVOMo BY636 404/V8 8AG	DCUA	RWH	QUT
4V14D9	2020	E	SUV KoVOMo BY636 404/V8 8AG	DCUA	RWH	QUT
4V14D9	2021	E	SUV KoVOMo BY636 404/V8 8AG	DCUA	RWH	QUT

New Continental GT and GTC

Sales types

Type	MY	Brand	Designation	Engine code	Gearbox code	Final drive code
3S32CB	2020	E		*	*	*
3S32CB	2021	E		*	*	*
3S42CB	2020	E		*	*	*
3S42CB	2021	E		*	*	*

Documents

Document name
master.xml

Customer statement / workshop findings

Emission Control Lamp illuminated on Driver Instrument Panel. The time to reach the correct engine coolant operating temperature has increased.



Diagnostic Trouble Code (DTC) 'P218100 - Cooling System Performance' is stored in the Engine Control Module (ECM), the vehicle "warm up" time is longer when compared to other vehicles of the same type.

Technical background

It is possible for the engine coolant Thermostat to corrode overtime, this corrosion is due to an adverse reaction of the Thermostat material with the engine coolant.

The corrosion and subsequent build-up of debris prevents the correct operation of the thermostat when closing, resulting in over cooling. The ECM triggers a DTC when the target engine temperature is outside of the specified parameter.

Production change

Under investigation.

Measure

With a confirmed Customer complaint of MIL activation, accompanied with DTC 'P218100, Cooling System Performance' proceed to replace the engine coolant thermostat, refer to 19 – Engine cooling – Coolant regulator (Thermostat insert) (V8 biturbo) – To remove and fit. Once completed, retest the vehicle to ensure correct functionality.

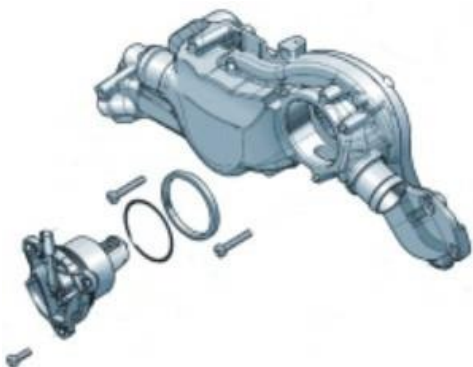

Parts information

Refer to the electronic parts catalogue (ETKA).