



Service Bulletin

Bulletin No.: 20-NA-183

Date: September, 2020

TECHNICAL

Subject: Summit White Paint on Front Impact Bar Appears Off-Color, Slightly Yellow

Brand:	Model:	Model Year:		from Date Breakpoint	to VIN Breakpoint:	Engine:	Transmission:
		from	to				
GMC	Sierra 1500	2020	2020	July 7, 2020	1GTP9EEL1LZ317323	All	All

Involved Region or Country	North America, Saudi Arabia
-----------------------------------	-----------------------------

Additional Options (RPOs)	
----------------------------------	--



Condition

5647155



5647156

	Some customers may comment on, in comparison to adjacent painted panels (2), the Summit White paint on front impact bar (1) appears off-color; slightly yellow.
Cause	The cause of the condition may be that contaminated paint from the bumper supplier may have been applied to a small window of the bumpers installed on vehicles.
Correction	Note: There are approximately 70 vehicles known to be affected by this condition Verify the vehicle is within the breakpoints of the condition, then follow the steps in the Service Procedure below.

Service Procedure

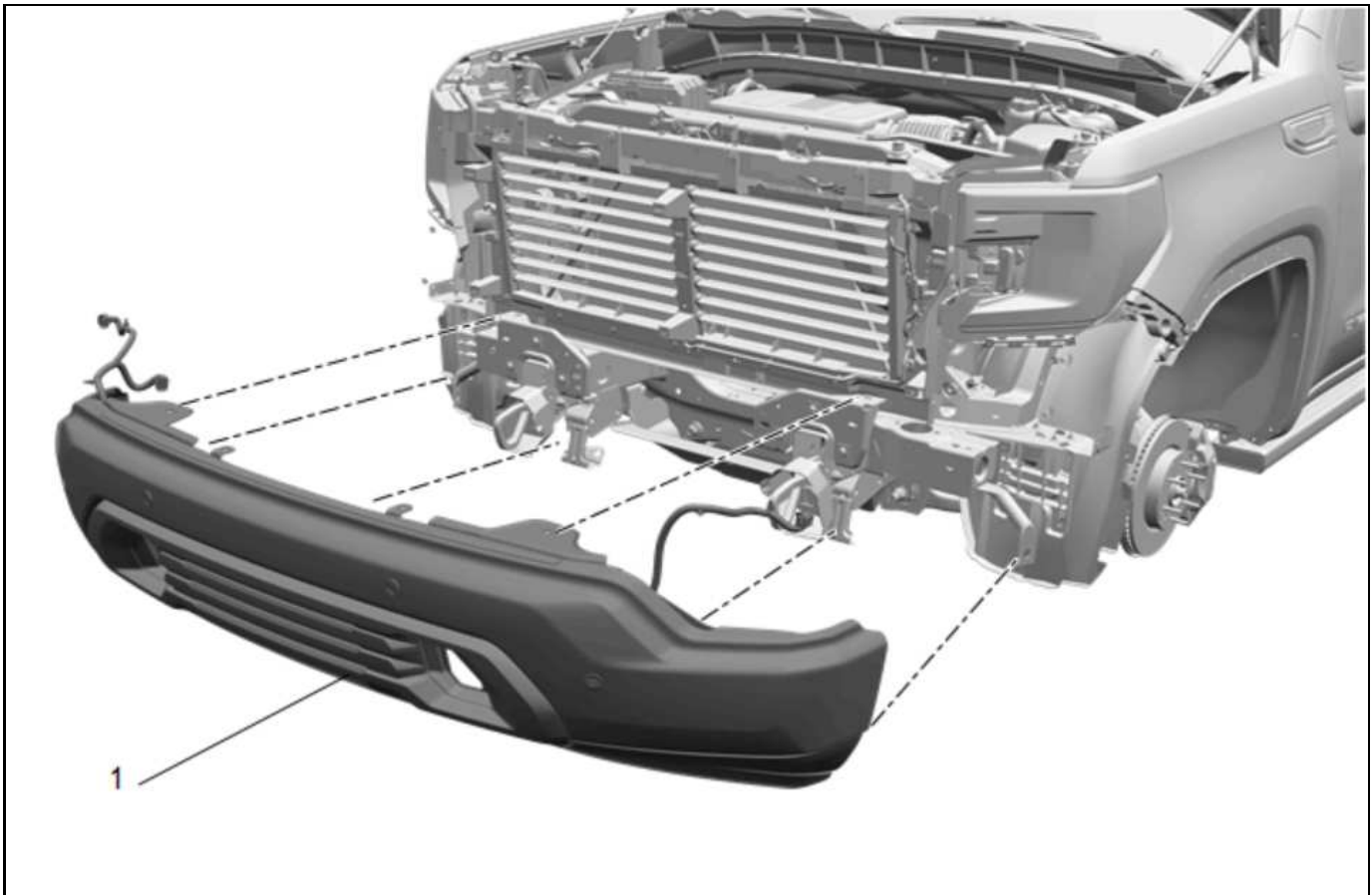

5047066

1. Remove the front impact bar (1) from the vehicle. Refer to *Front Bumper Impact Bar Replacement*, in SI.

Note: Summit White paint color code 8624.

2. Refinish with proper paint color and clear coat.

Note: Refer to the latest revision of the GM Approved Refinish Materials book to identify the paint systems you may use that have been engineered to meet GM standards.

The latest revision of the GM Approved Refinish Materials booklet is located on the Genuine GM Parts website at www.genuinegmparts.com and also within the "Unit Repair Manual/Specialty Publication" section of GM Service Information (SI).

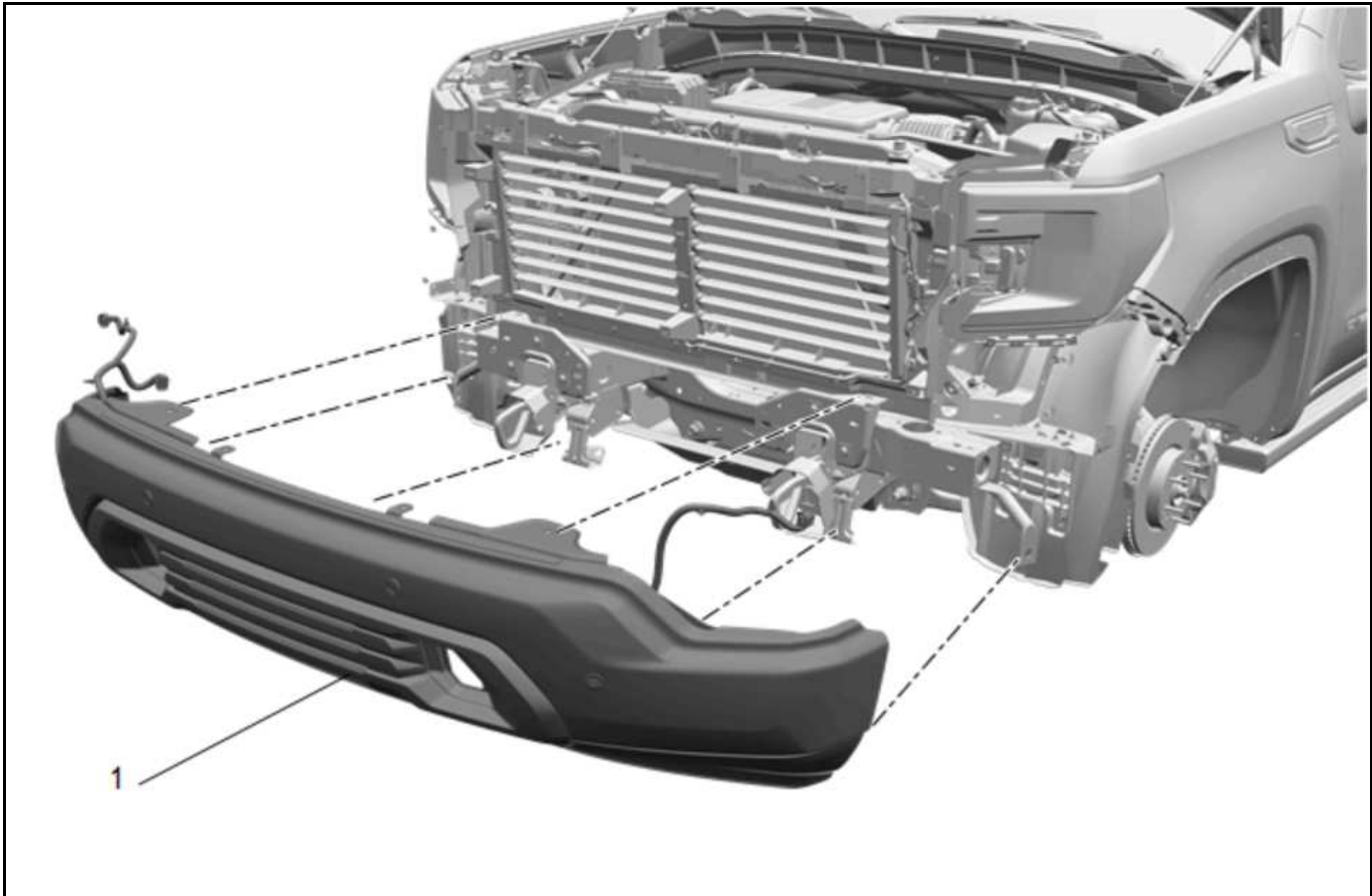

5047066

3. Reinstall the impact bar (1). Refer to *Front Bumper Impact Bar Replacement*, in SI.

Parts Information

No parts are required for this repair.

Warranty Information

For vehicles repaired under warranty, use:

Labor Operation	Description	Labor Time
1420300	Front Bumper Impact Bar Replacement	Use Published Labor Operation Time

Version	1
Modified	Released September 09, 2020

GM bulletins are intended for use by professional technicians, NOT a "do-it-yourselfer". They are written to inform these technicians of conditions that may occur on some vehicles, or to provide information that could assist in the proper service of a vehicle. Properly trained technicians have the equipment, tools, safety instructions, and know-how to do a job properly and safely. If a condition is described, DO NOT assume that the bulletin applies to your vehicle, or that your vehicle will have that condition. See your GM dealer for information on whether your vehicle may benefit from the information.



WE SUPPORT VOLUNTARY
TECHNICIAN
CERTIFICATION