



PROTERRA



TECHNICAL SERVICE BULLETIN

ISSUE DATE:	2-4-2020
SERVICE BULLETIN SUBJECT:	Grayson Unit Bracket Retrofit
VINs or MODELS AFFECTED:	Service Specified Buses
COMPLETE BY:	Next Service Opportunity
SERVICE BULLETIN #:	SC-20-25

NOTICE! It is expected that this process will require 4 hours per bus. Please schedule appropriately to minimize vehicle downtime.

GRAYSON UNIT BRACKET RETROFIT

Retrofit Description:

This procedure is a updates the Grayson unit brackets to a more robust design.

Tools/Parts Required

Tools and Supplies Required:

- As Shown in Attached OEM Procedure

Parts Required:

- 054670 KIT, RETROFIT, GRAYSON BRACKET UPGRADE (Consisting of)
 - 112-0216 RIVET, MONOBOLT, 0.25IN 20 EA
 - 111-9540 BRACKET, GRAYSON, FRAME SUPPORT 4 EA

Procedure

1. Complete the Proterra approved Lockout/Tagout procedure to make the bus safe for work.



2. Use Proterra and Transit Agency approved safety procedures and PPE to safely access the rooftop of the bus.
3. Complete the attached OEM procedure that is attached to this document in its entirety.
4. Once the OEM Procedure is complete, remove the Lockout/Tagout devices and power on the bus.
5. Return the bus to service.

Standard Operating Procedure: Replacement of Proterra mounting brackets

Operation Steps

1

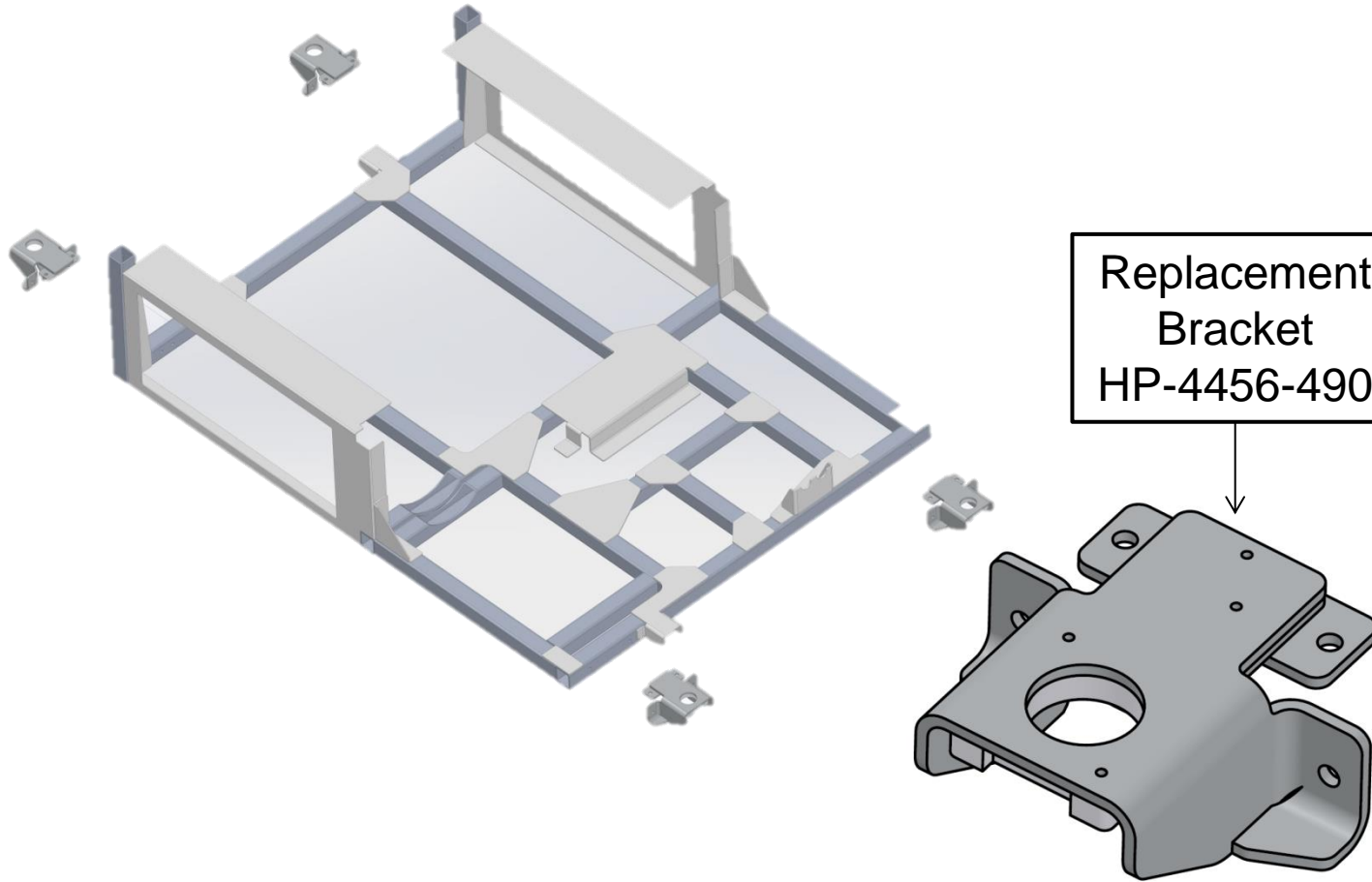

This document details the removal of old brackets and the fixing of the new style bracket to the frame.

Please note that cycle time for the complete operation has been set at 40 Minutes



Reference Documents

Accept / Reject Criteria

Inspection / Test Required



IF IN DOUBT ALWAYS ASK

Operation Name	Tools & Equipment Required	Personal Protective Equipment Required	Reason for Revision	Date	26/01/20
Overview		 		Doc No.	617
				Revision	A
				Cycle Time	40 mins
				Originator	S.REED
				Approved	T ALLAN

Standard Operating Procedure: Replacement of Proterra mounting brackets

Operation Steps

2

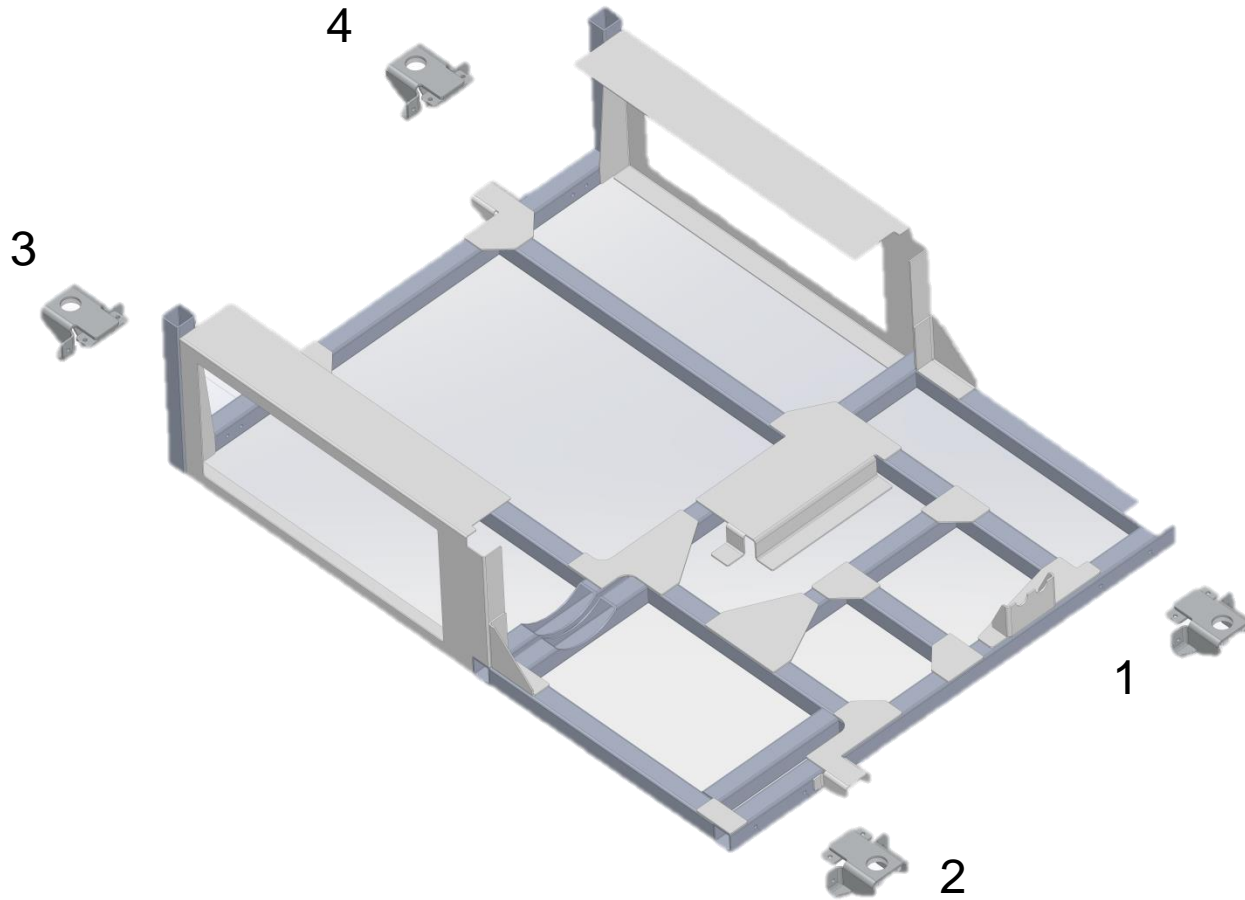

For engineers reference, the brackets are numbered here.

New bracket part reference:
HP-4456-490

- 1 = CS Front
- 2 = CS Rear
- 3 = SS Rear
- 4 = SS Front

Reference Documents

Accept / Reject Criteria

Inspection / Test Required



IF IN DOUBT ALWAYS ASK

Operation Name	Tools & Equipment Required	Personal Protective Equipment Required
----------------	----------------------------	----------------------------------------

Bracket Identification.



Reason for Revision	Date	26/01/20
	Doc No.	617
	Revision	A
	Cycle Time	
	Originator	S.REED
	Approved	T ALLAN

Standard Operating Procedure: Replacement of Proterra mounting brackets

Operation Steps

3



IF IN DOUBT ALWAYS ASK

Begin with bracket 1.



Begin by removing all external covers from the unit. This can be done with a powered tool or socket.

Reference Documents

Accept / Reject Criteria

Inspection / Test Required



Operation Name	Tools & Equipment Required	Personal Protective Equipment Required	Reason for Revision	Date	26/01/20
Removal of Cover	13mm socket	 		Doc No.	617
				Revision	A
				Cycle Time	
				Originator	S.REED
				Approved	T ALLAN

Standard Operating Procedure: Replacement of Proterra mounting brackets

Operation Steps

4



Mask the internal components with a piece of thick cardboard or a piece of hardboard as shown.



Reference Documents

Accept / Reject Criteria

Inspection / Test Required

IF IN DOUBT ALWAYS ASK



Operation Name	Tools & Equipment Required	Personal Protective Equipment Required	Reason for Revision	Date	26/01/20
Masking the internal workings.	Card / Hardboard	 		Doc No.	617
				Revision	A
				Cycle Time	
				Originator	S.REED
				Approved	T ALLAN

Standard Operating Procedure: Replacement of Proterra mounting brackets

Operation Steps

5

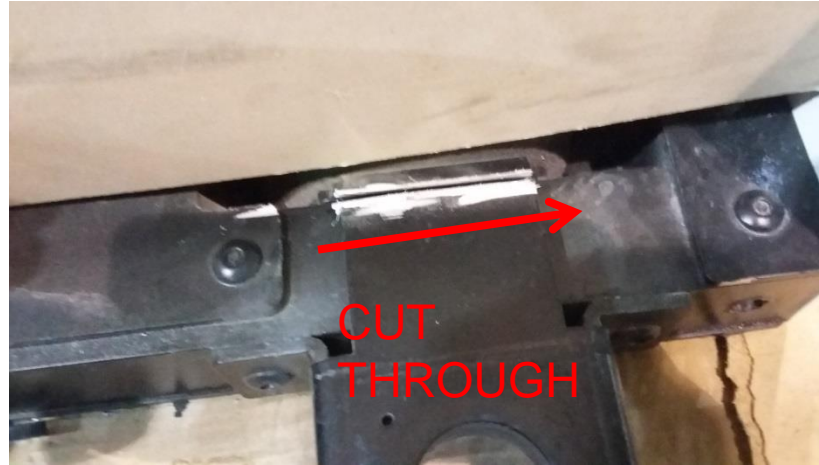

Slit the back of the bracket using an angle grinder and a thin 'slitting' disc as shown.





IF IN DOUBT ALWAYS ASK

Reference Documents

Accept / Reject Criteria

Inspection / Test Required



Operation Name	Tools & Equipment Required	Personal Protective Equipment Required	Reason for Revision	Date	26/01/20
Slit back of Bracket	Angle Grinder, Slitting Disc	  		Doc No.	617
				Revision	A
				Cycle Time	
				Originator	S.REED
				Approved	T ALLAN

Standard Operating Procedure: Replacement of Proterra mounting brackets

Operation Steps

6



Bracket No 2 requires an additional operation.

Because the fastener which secures the bracket to the frame is stainless, it is not feasible to drill the head out, it must be cut.

It will be found that the left hand stud is accessible with the grinder, but the right is not.

Cut the head off the left hand stud and then slit the bracket as shown. The section can then be removed and the tab folded over to create access to the second stud.

Reference Documents

Accept / Reject Criteria

Inspection / Test Required

IF IN DOUBT ALWAYS ASK



Operation Name

Tools & Equipment Required

Personal Protective Equipment Required

Remove Stud Heads

Angle Grinder, Slitting Disc



Reason for Revision

Date

26/01/20

Doc No.

617

Revision

A

Cycle Time

Originator

S.REED

Approved

T ALLAN

Standard Operating Procedure: Replacement of Proterra mounting brackets

Operation Steps

7



Knock the old studs inside the box section, and offer the bracket up. It should be found that the new bracket's holes line up with the existing holes in the box.

Insert a Monobolt into the holes.



Reference Documents

Accept / Reject Criteria

Inspection / Test Required



IF IN DOUBT ALWAYS ASK

Operation Name	Tools & Equipment Required	Personal Protective Equipment Required	Reason for Revision	Date	26/01/20
Fit Monobolt	Monobolt Gun	 		Doc No.	617
				Revision	A
				Cycle Time	
				Originator	S.REED
				Approved	T ALLAN

Standard Operating Procedure: Replacement of Proterra mounting brackets

Operation Steps

8



Fasten both Rivnuts.

Reference Documents

Accept / Reject Criteria

Inspection / Test Required



IF IN DOUBT ALWAYS ASK

Operation Name

Tools & Equipment Required

Personal Protective Equipment Required

Fasten Monobolt

Monobolt Gun



Reason for Revision

Date

26/01/20

Doc No.

617

Revision

A

Cycle Time

Originator

S.REED

Approved

T ALLAN

Standard Operating Procedure: Replacement of Proterra mounting brackets

Operation Steps

9

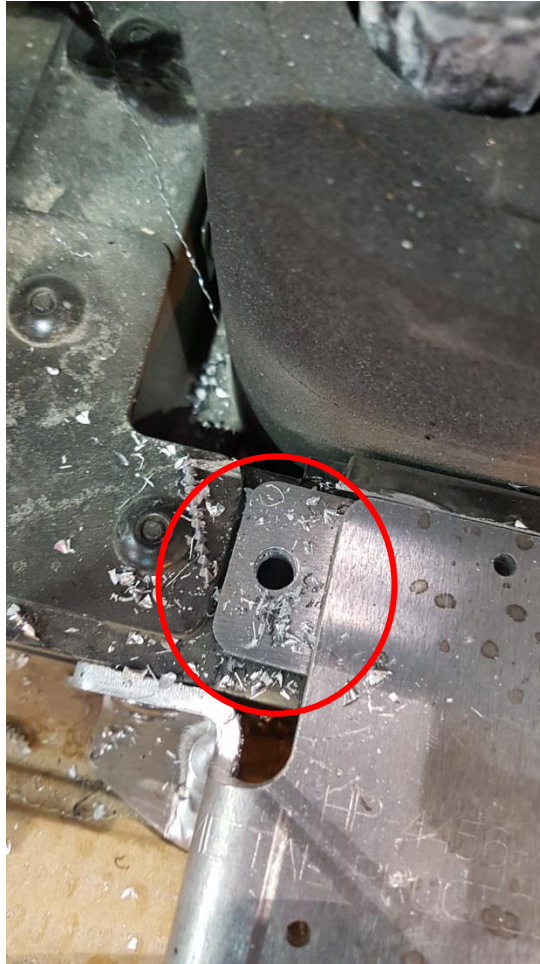

Use a 6.5mm drill to drill holes for the other three required Monobolts. Use the hole in the bracket as a guide, as it is aluminium a sharp drill will make light work of the hole without a pilot. .



IF IN DOUBT ALWAYS ASK

Reference Documents

Accept / Reject Criteria

Inspection / Test Required



Operation Name	Tools & Equipment Required	Personal Protective Equipment Required	Reason for Revision	Date	26/01/20
Drill new hole	Drill, 6.5mm Drill Bit	  		Doc No.	617
				Revision	A
				Cycle Time	
				Originator	S.REED
				Approved	T ALLAN

Standard Operating Procedure: Replacement of Proterra mounting brackets

Operation Steps

10



Don't forget the hidden hole underneath the bracket.

Fasten the three Monobolt.

IF IN DOUBT ALWAYS ASK

Reference Documents

Accept / Reject Criteria

Inspection / Test Required



Operation Name

Tools & Equipment Required

Personal Protective Equipment Required

Drill new holes

Drill, 13mm drill bit,
Monobolt gun



Reason for Revision

Date

26/01/20

Doc No.

617

Revision

A

Cycle Time

Originator

S.REED

Approved

T ALLAN

Standard Operating Procedure: Replacement of Proterra mounting brackets

Operation Steps

11



Repeat the process. The bracket next to the copper pipe requires great care to prevent damage to the pipework.

If a full slit cannot be achieved a ¾ slit is sufficient as the rest of the section can be snapped off.

IF IN DOUBT ALWAYS ASK

Reference Documents

Accept / Reject Criteria

Inspection / Test Required



Operation Name

Tools & Equipment Required

Personal Protective Equipment Required

Section Bracket.

Angle Grinder, Slitting Disc



Reason for Revision

Date

26/01/20

Doc No.

617

Revision

A

Cycle Time

Originator

S.REED

Approved

T ALLAN

Standard Operating Procedure: Replacement of Proterra mounting brackets

Operation Steps

12

For bracket No 3 & 4, cut as shown.

A full slit across the back is not possible as the guard of the grinder will foul on the frame.

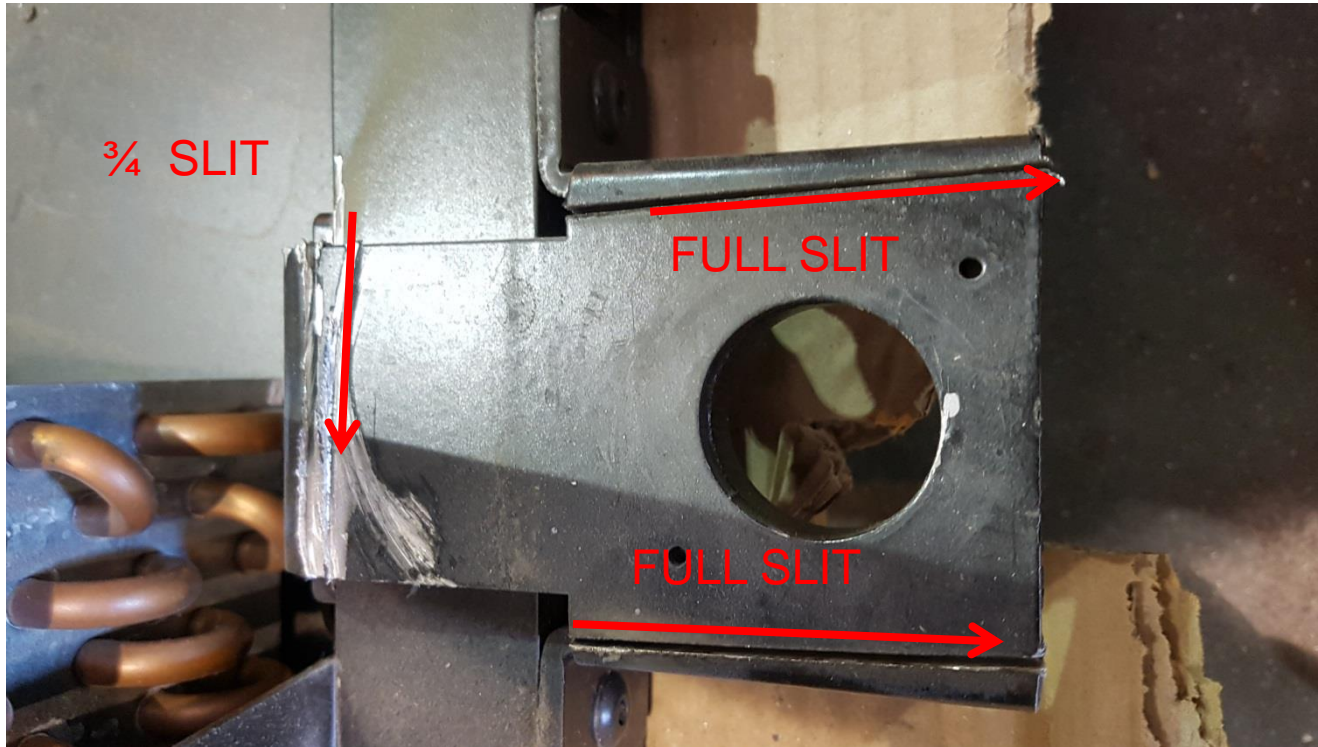



IF IN DOUBT ALWAYS ASK

Reference Documents

Accept / Reject Criteria

Inspection / Test Required



Operation Name	Tools & Equipment Required	Personal Protective Equipment Required
Section Bracket	Angle Grinder, Slitting Disc	  

Reason for Revision	Date	26/01/20
	Doc No.	617
	Revision	A
	Cycle Time	
	Originator	S.REED
	Approved	T ALLAN

Standard Operating Procedure: Replacement of Proterra mounting brackets

Operation Steps

13

Once the full slits are complete, the middle will bend up and can be snapped off.

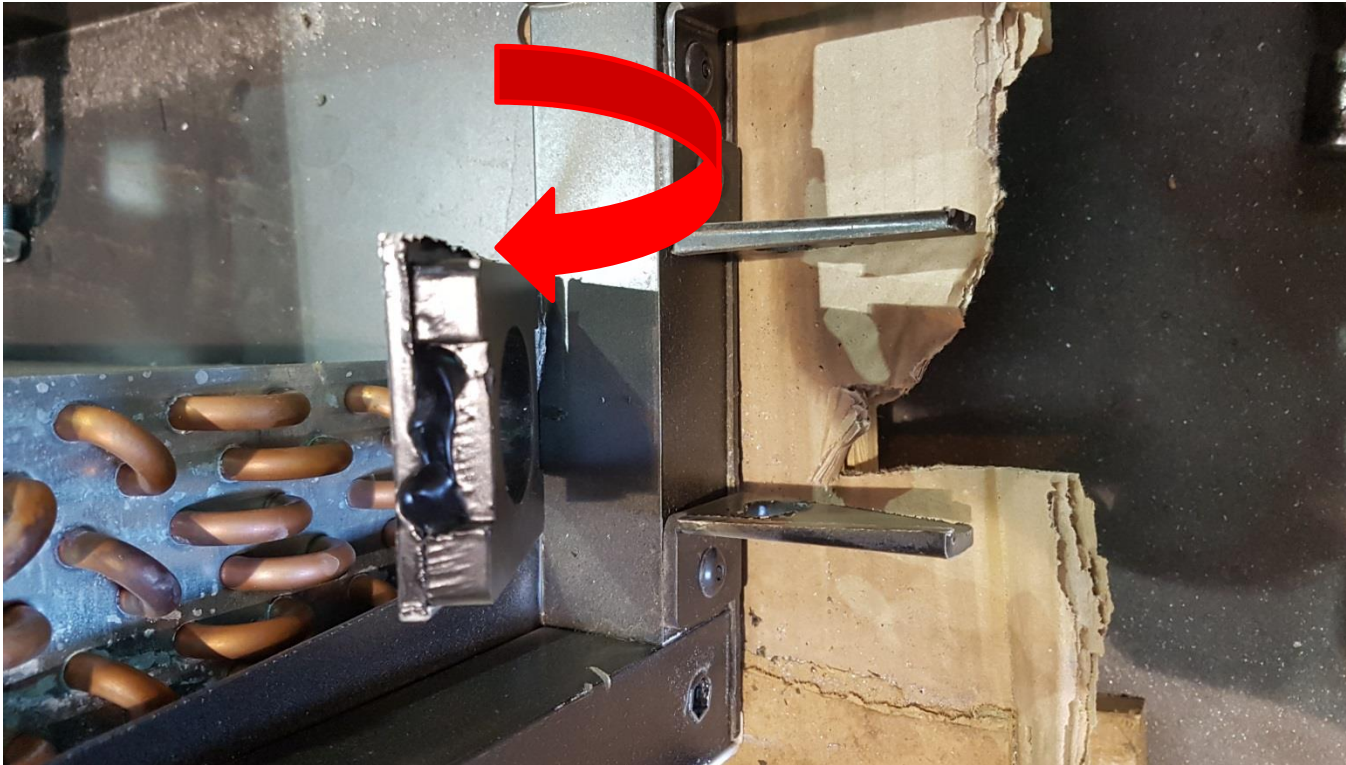

IF IN DOUBT ALWAYS ASK

Reference Documents

Accept / Reject Criteria

Inspection / Test Required



Operation Name

Tools & Equipment Required

Personal Protective Equipment Required

Bend and Snap Remaining Tab



Reason for Revision

Date

26/01/20

Doc No.

617

Revision

A

Cycle Time

Originator

S.REED

Approved

T ALLAN

Standard Operating Procedure: Replacement of Proterra mounting brackets

Operation Steps

14

Tap the two remaining tabs flat to the box section. The grinder will then have access to cut the studs off.



IF IN DOUBT ALWAYS ASK

Reference Documents

Accept / Reject Criteria

Inspection / Test Required



Operation Name

Tools & Equipment Required

Personal Protective Equipment Required

Beat tabs Flat

Ball Pein Hammer



Reason for Revision

Date

26/01/20

Doc No.

617

Revision

A

Cycle Time

Originator

S.REED

Approved

T ALLAN

Standard Operating Procedure: Replacement of Proterra mounting brackets

Operation Steps

15



The replacement is complete when all four brackets are fitted with five Monobolt each.



Reference Documents

Accept / Reject Criteria

Inspection / Test Required



IF IN DOUBT ALWAYS ASK

Operation Name	Tools & Equipment Required	Personal Protective Equipment Required	Reason for Revision	Date	26/01/20
Insert new Monobolts	Monobolt Gun	 		Doc No.	617
				Revision	A
				Cycle Time	
				Originator	S.REED
				Approved	T ALLAN

Standard Operating Procedure: Replacement of Proterra mounting brackets

Operation Steps

16

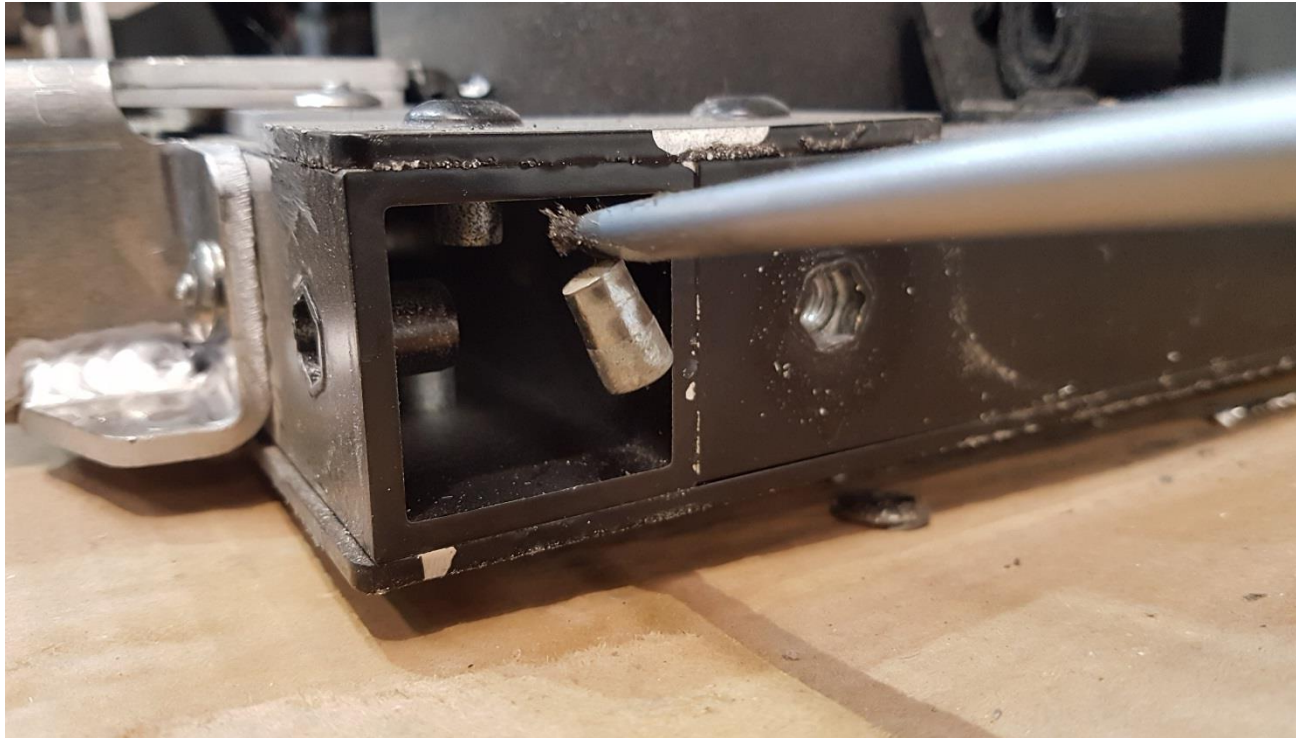

The last step is to remove the old studs which were knocked through into the box section.

These are very slightly magnetic, so a magnetic end screwdriver or telescopic magnet can be inserted into the end of the box and the stud carefully removed.



Reference Documents

Accept / Reject Criteria

Inspection / Test Required

IF IN DOUBT ALWAYS ASK



Operation Name	Tools & Equipment Required	Personal Protective Equipment Required	Reason for Revision	Date	26/01/20
Recover Old Studs From Assembly	Magnetic long reach tool	 		Doc No.	617
				Revision	A
				Cycle Time	
				Originator	S.REED
				Approved	T ALLAN

Standard Operating Procedure: Replacement of Proterra mounting brackets

Operation Steps

17



Replace all covers. If you are not using a powered tool with a set torque, torque all bolts manually to 11NM for M6, and 30NM for M8



Reference Documents

Accept / Reject Criteria

Inspection / Test Required

IF IN DOUBT ALWAYS ASK



Operation Name	Tools & Equipment Required	Personal Protective Equipment Required
Replace Covers.	Torque Wrench, 10mm Socket ,13mm socket	 

Reason for Revision	Date	26/01/20
	Doc No.	617
	Revision	A
	Cycle Time	
	Originator	S.REED
	Approved	T ALLAN