



Technical Service Bulletin

GROUP

STEERING

NUMBER

20-DS-002H

DATE

SEPTEMBER, 2020

MODEL(S)

GENESIS (DH)

SUBJECT: 2015-2016MY GENESIS (DH) 3.8L AWD PROPELLER SHAFT VIBRATION

Description: The bulletin describes the procedure to measure and set propeller shaft angles to optimize driveline vibration performance on certain 2015-2016MY 3.8L AWD G80 (DH) vehicles.

NOTICE

For 2015-2016MY Genesis 3.8L AWD vehicles, **perform the propeller shaft replacement first.** If the vibration persists after parts replacement, continue to the propeller shaft angle inspection service procedure.





Applicable Vehicles: 15-16MY Hyundai Genesis (DH) 3.8L AWD vehicles.



SUBJECT:

15-16MY GENESIS (DH) AWD PROPELLER SHAFT

Parts Information:

PART NAME	PART NUMBER	IMAGE	REMARKS
Washer	13510-10007B		Qty of required washers depends on change of angles required.
Propeller Shaft 3.8L AWD	49100-B1300		N/A

SST Information:

PART NUMBER / DESCRIPTION	IMAGES
09958-3T100 Digital Inclinometer <div style="border: 1px solid black; padding: 5px;"> <p style="background-color: blue; color: white; text-align: center; margin: 0;">NOTICE</p> <p>Digital inclinometer is part of the BCW Unit Correction Tool Set (09958-3T500).</p> <p>The digital inclinometer (P/N 09958-3T100) is not available as a separate tool.</p> <p>If a replacement digital inclinometer/protractor is needed, please order this model from an online retailer: https://www.digipas.com/product/precision-measurement/pocket-size-digital-level/dwl-80e.php</p> </div>	 

Warranty Information:

MODEL	OP CODE	OPERATION	OP TIME	CAUSAL PART	NATURE CODE	CAUSE CODE
Genesis (DH) AWD	49100F07	Test Drive	0.3 M/H	49100- B1300	Q55	ZZ1
	49100F08	Test Drive, Replace Propeller Shaft, Test Drive	1.8 M/H			
	49100F09	Test Drive, Replace Propeller Shaft, Test Drive, Measure Angles and Washer Installation, Final Test Drive.	2.9 M/H			

NOTICE

Normal warranty applies.

Service Procedure: Flowchart

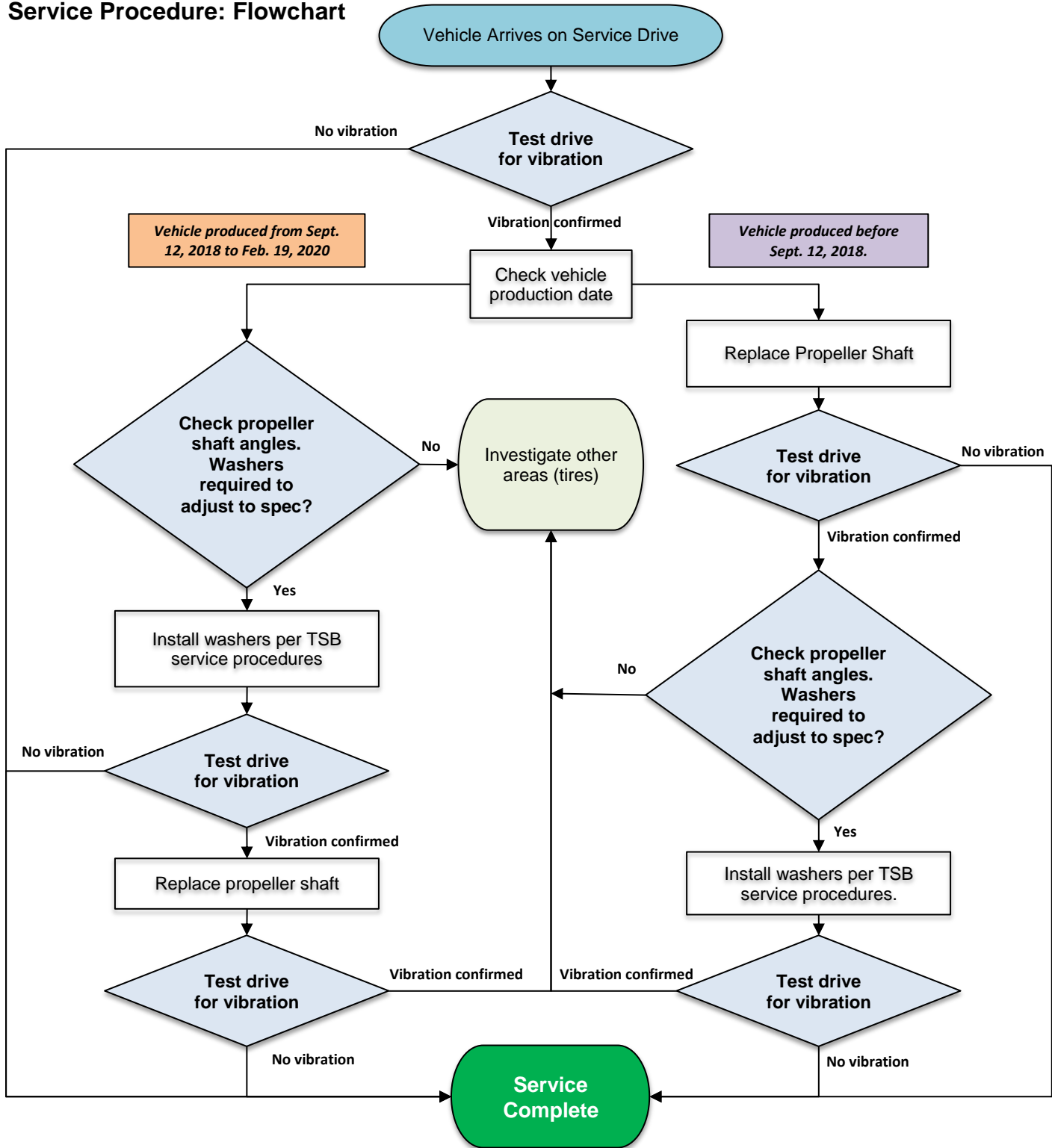

Service Procedure: Propeller Shaft Replacement

Replace the propeller shaft per service manual procedures:

* Driveshaft and axle > Front Propeller Shaft Assembly > Propeller Shaft

Perform a test drive to confirm if vibration is resolved. If the vibration is not resolved, continue to the propeller shaft angle inspection service procedures below.

Service Procedure: Propeller Shaft Angle Inspection

► PROTRACTOR (digital inclinometer) USAGE



Bottom surface of protractor is magnetic.



To initialize angle measurements, set the protractor against a reference surface. When the reference position is set, press the **All Zero** button to set to zero (0).



Arrows indicate positive or negative angles.

IMPORTANT

Orientation of the protractor affects the measurement reading.

Always orient the protractor so that the LCD display can be read from the DRIVER'S SIDE of the vehicle.

This will ensure that positive (+) measurements (UP arrow) will be consistent with the definitions in this TSB.



► PROPELLER SHAFT ANGLE DEFINITIONS

IMPORTANT

The propeller shaft angles $\Theta 1$ and $\Theta 2$ are defined as follows:

($\Theta 1$): Angle Between Engine/Trans To Front Shaft Section

($\Theta 2$): Angle Between Front and Rear Shaft Sections

(A): Protractor Angle Measurement Position

PLEASE NOTE $\Theta 1$ and $\Theta 2$ have different reference positions. This means the protractor must be zeroed on the transmission for $\Theta 1$, and then re-zeroed on the front of the propeller shaft for $\Theta 2$.

Angle Specifications (degrees) are shown below. If the measured angles are not within these specifications, washers must be installed to adjust the angles to specifications, as described in the service procedures below.

Propeller Shaft Angle Specifications:

$\Theta 1$: -0.6 to 0.4°

$\Theta 2$: -0.3 to 0.7°

*** The $\Theta 1$ angle directions are positive (+) when the front portion of the propeller shaft slopes downwards (front to back) when compared to the transmission, and negative (-) when the front portion of the propeller shaft slopes upwards.

*** The $\Theta 2$ angle directions are positive (+) when the rear portion of the propeller shaft slopes downwards (front to back) when compared to the front portion of the propeller shaft, and negative (-) when the rear portion propeller shaft slopes upwards.

Overview of driveline angles

*** Angle +/- Direction

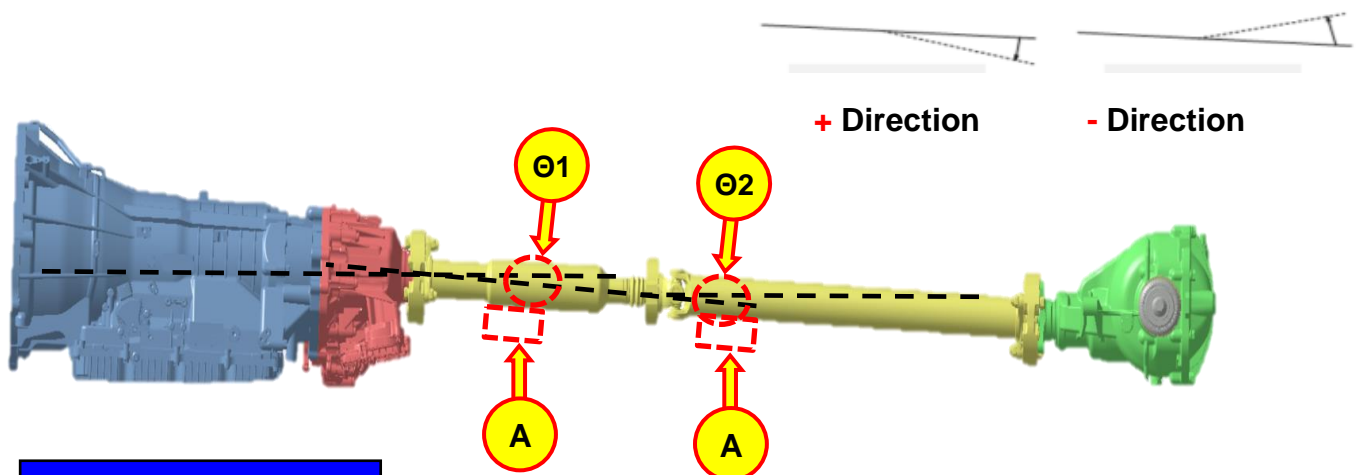
**IMPORTANT**

The propeller shaft angles $\Theta 1$ and $\Theta 2$ are defined as follows:

($\Theta 1$): Angle Between Engine/Trans To Front Shaft Section

($\Theta 2$): Angle Between Front and Rear Shaft Sections

(A): Protractor Angle Measurement Position

Θ1 detailed view

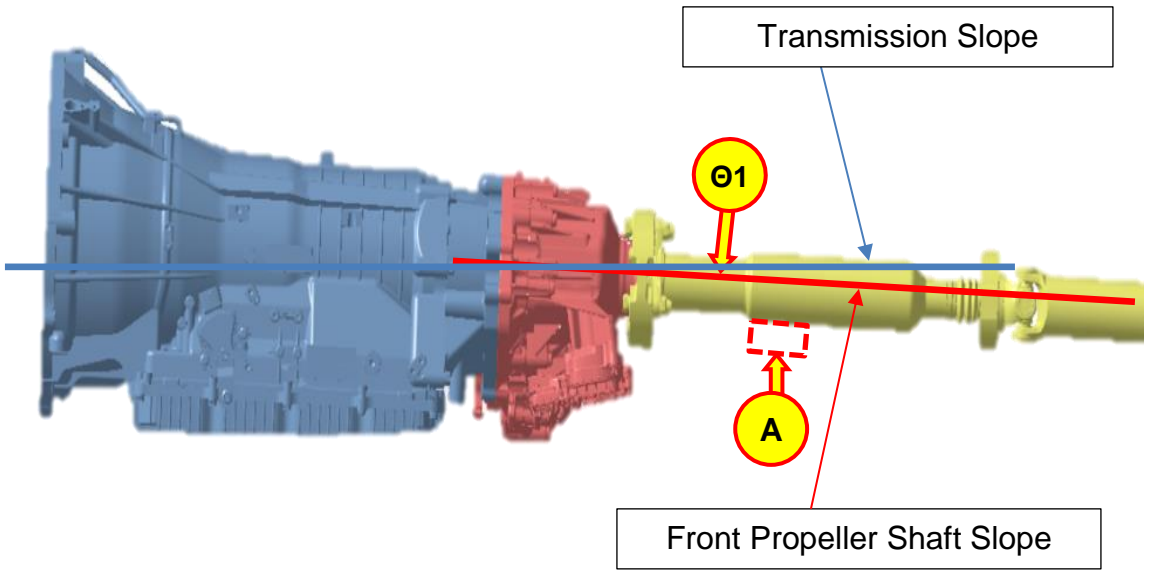

Θ2 detailed view

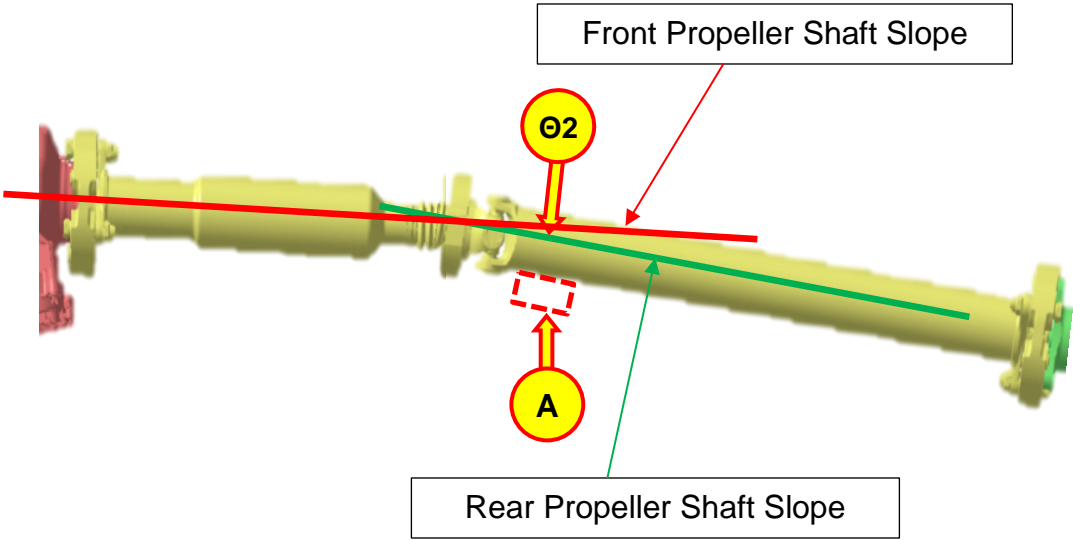

1. Remove the center muffler assembly according to the vehicle shop manual.

** Engine Mechanical System > Intake and Exhaust System > Muffler*

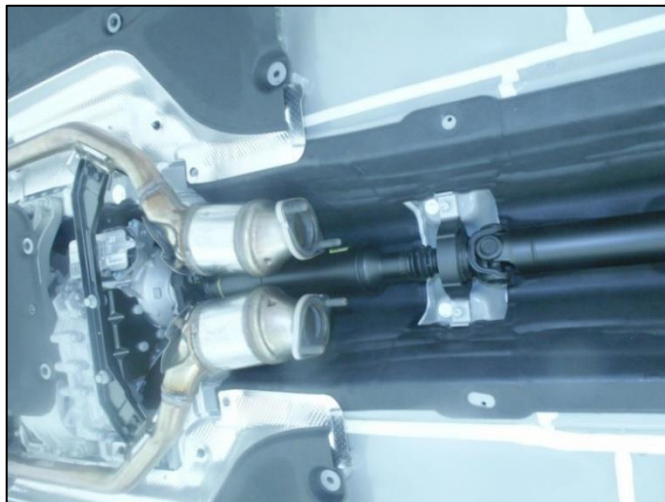

2. Place and hold the protractor to the transmission LH flange face to set the transmission reference angle to zero (0.0).

Press the All Zero button to set zero (0.0).

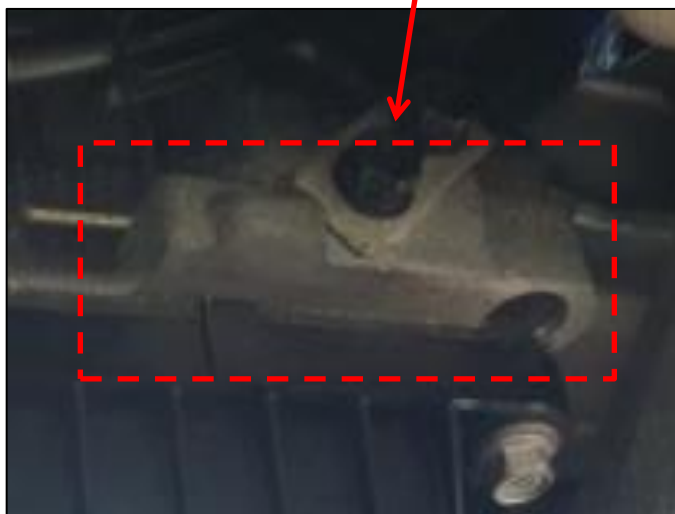
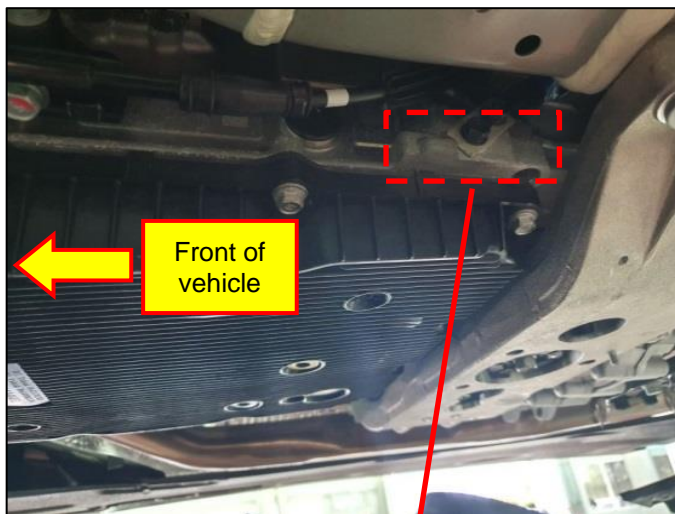

3a. ► *Measure (Θ1): Angle Between Engine/Trans To Front Shaft Section*

After setting the zero (0.0) reference angle at the transmission flange, move the protractor to the front portion of the propeller shaft.

Verify the protractor is positioned properly on the propeller shaft, with the length of the protractor parallel to the propeller shaft tube, and the protractor body pointed at a right angle to the ground.



Refer to the image to the right.

3b. After properly positioning the protractor, check the angle measurement reading on the display and record the value. Do not move the protractor.



▼ 1.2°

> *Front Tube Angle (Θ1) measurement value: 1.2°, ↖ direction*



NOTICE

**Angle Specifications (degrees):
Θ1: -0.6 to 0.4°**

3c. Without moving the protractor, reset the zero (0.0) reference value after recording Θ1.



4a. **► Measure ($\Theta 2$): Angle Between Front and Rear Shaft Sections**

Move the protractor to the rear section of the propeller shaft.

Verify the protractor is positioned properly on the propeller shaft, with the length of the protractor parallel to the propeller shaft tube, and the protractor body pointed at a right angle to the ground.

Refer to the reference image on the right.



4b. After properly positioning the protractor, check the angle measurement reading on the display and record the value.



> **Rear Tube Angle ($\Theta 2$) measurement value: 0.5°, '+' direction**

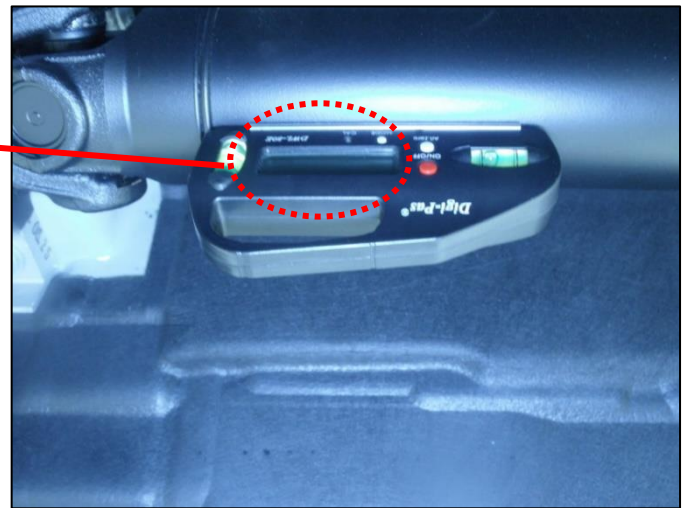

NOTICE
Angle Specifications (degrees):
 $\Theta 2$: -0.3 to 0.7°

5. If required, install washers to adjust angles $\Theta 1$ and $\Theta 2$ to specification.

If the greatest angle change needed is to adjust $\Theta 2$ in the negative (-) direction, follow the procedures described in Case 1 below.

If the greatest angle change needed is to adjust $\Theta 1$ in the positive (+) direction, follow the procedures described in Case 2 below.

6a. ► Case 1 – Install flat washers at center support bearing.

Install washers at the propeller shaft center support bearing when the largest angle change needed is to adjust $\Theta 2$ in the negative direction.

NOTICE

Use a screw-jack to carefully support the propeller shaft during this procedure. Do not allow the propeller shaft to fall onto the screw jack. Any damage to the propeller shaft may cause an imbalance.

6b. Remove the propeller shaft center bearing bolts.

TIGHTENING TORQUE

lb.ft	•36.1 - 47.0
kgf.m	•5.0 - 6.5
N.m	•49.0 - 63.7

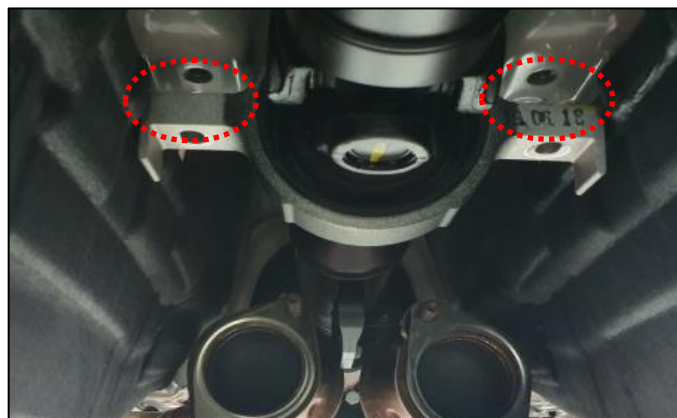

6c. Install the washers above the center bearing mounting bracket.

NOTICE

A total of up to 3 washers is possible on each side. Use an equal number of washers on each side.

Each washer will change the angles of $\Theta 1$ and $\Theta 2$ by the amount of degrees shown in the table below. Add or subtract the angles shown from the measured angles to determine if the angles will be within specification.



	$\Theta 1$	$\Theta 2$
SPEC	- 0.6 To 0.4°	- 0.3 To 0.7°
1 WASHER	+ 0.14°	- 0.18°
2 WASHERS	+ 0.37°	- 0.55°
3 WASHERS	+ 0.6°	- 0.92°

*** CHANGE OF $\Theta 1$, $\Theta 2$ ANGLE (degrees)**

7a. **► Case 2 – Install flat washers at the transmission mounting bracket.**

Install washers at the transmission mounting bracket when the largest angle change needed is to adjust $\Theta 1$ in the positive direction.

NOTICE

Use a screw-jack to support the transmission during this procedure.

7b. Remove the T/M mounting bracket.

TIGHTENING TORQUE (all circled fasteners):

lb.ft	•36.1 - 47.0
kgf.m	•5.0 - 6.5
N.m	•49.0 - 63.7

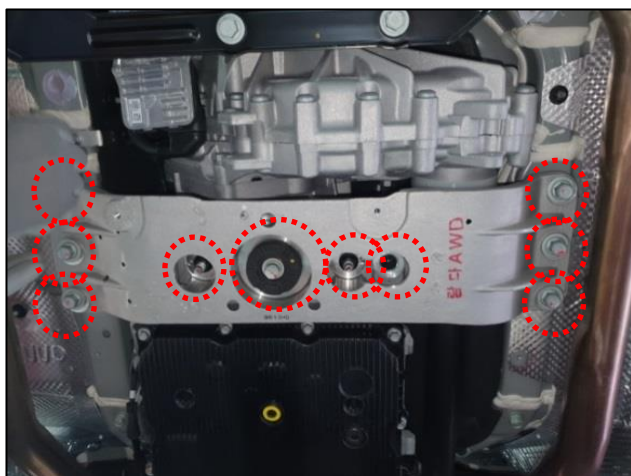

7c. Install the washers above the T/M mounting bracket and the insulator.

NOTICE

A total of up to 2 washers is possible in each location. Use an equal number of washers at each location.



Each washer will change the angles of $\Theta 1$ and $\Theta 2$ by the amount of degrees shown in the table below. Add or subtract the angles shown from the measured angles to determine if the angles will be within specification.

	$\Theta 1$	$\Theta 2$
SPEC	- 0.6 To 0.4°	- 0.3 To 0.7°
1 WASHER	+ 0.36°	- 0.14°
2 WASHERS	+ 0.88°	- 0.51°

* **CHANGE OF $\Theta 1$, $\Theta 2$ ANGLE (degrees)**



8. After installing the washers to adjust the propeller shaft angles within specification, reinstall the removed parts in reverse order of removal.
9. Follow steps 1 through 4 to measure **Θ1** and **Θ2** again to verify the angles are within specification.
10. Perform a road test to evaluate vibration. If the vibration is resolved, the service procedure is complete.

If the vibration is not resolved, inspect other areas of the vehicle for potential vibration sources.