

Technical product information

Topic	Bentayga - Check Engine Lamp - Fuel Pressure Regulation
Market area	Bentley: worldwide (2WBE)
Brand	Bentley
Transaction No.	2058484/2
Level	EH
Status	Approval
Release date	

New customer code

Object of complaint	Complaint type	Position
information, navigation, communication, entertainment -> symbolic fault indicators -> fault indicator for fuel system	functionality -> activates	
information, navigation, communication, entertainment -> symbolic fault indicators -> emission control system fault indicator	functionality -> activates	

New workshop code

Object of complaint	Complaint type	Position
engine -> fuel supply -> low-pressure fuel pump (tank)	functionality -> uneven	
engine -> operation, engine control -> engine control unit	functionality -> misfire	
engine -> operation, engine control -> engine control unit	electrics -> ground connection damaged	
engine -> operation, engine control -> engine control unit	control units, services -> with event log entry	
engine -> operation, engine control -> engine control unit	control units, services -> measured value too high	
engine -> operation, engine control -> engine control unit	control units, services -> error message	

Vehicle data

Bentayga

Sales types

Type	MY	Brand	Designation	Engine code	Gearbox code	Final drive code
4V14D9	2018	E	SUV KoVOMo BY636 404/V8 8AG	DCUA	RWH	QUT
4V14D9	2019	E	SUV KoVOMo BY636 404/V8 8AG	DCUA	RWH	QUT
4V14D9	2020	E	SUV KoVOMo BY636 404/V8 8AG	DCUA	RWH	QUT

Documents

Document name
master.xml
measurement.pdf

Customer statement / workshop findings

Check Engine Lamp illuminated on Driver Instrument Panel (DIP)

Diagnostic Trouble Code (DTC) "P310B00 Low Fuel Pressure Regulation" stored in the Engine Control Unit.

DTC "P014800 Fuel Delivery Error" stored in the Engine Control Unit.

"Misfire" DTC stored in the Engine Control Unit.

Technical background

There may be multiple DTC's and symptoms present due to fuel pressure regulation or fuel supply issues, use the information contained within the "Measure" section to determine the correct analysis and repair procedure.

Production change

Not applicable.

Measure

Please read the following document and select the correct *Measure* based upon the specific vehicle symptoms.

Measure 1 - Check Engine Lamp Illumination And DTC "P0310B00"

For vehicles that have only the symptoms "Check Engine Lamp Illumination", DTC "P0310B00" and an "Adaption of Fuel Pump (FP)" figure of minus 100 to minus 200 kPa – figure 1 - the Fuel Delivery Module within the fuel tank should be replaced – figure 2 – refer to *Repair Group 20 Fuel supply, gas operation / 4.0L V8 TSI / Fuel pump, fuel level sensors, and jet pump (RH) – To remove and fit.*

To check the "Adaption of Fuel Pump (FP)" figure within the fault memory, refer to Engine control Unit "01 – Engine Control Module 1" - From "Extended ambient conditions" note the value of the "Adaption of Fuel Pump (FP)" – figure 1.

Initial system test with fault memory entries

Address: 0001 System name: 01 - Engine Control Module 1 Protocol variant: UDS/ISOTP (Ereignisse: 1)

+ Identification:

- Event memory entries (Data source: Vehicle):

Entry in fault memory

Number:	P310B00: Low Fuel Pressure regulation Fuel pressure outside specification
Fault type 2:	passive/sporadic
Symptom:	2638
Status:	10101000

- Standard ambient conditions:

Date:	05/11/19
Time:	09:52:18
Mileage (DTC):	92
Priority:	2
Frequency counter:	8
Unlearning counter / driving cycle:	255

- Extended ambient conditions:

Engine speed	602.0	1/min
Normed load value	7.05882366	%
Vehicle speed	0	km/h
Coolant temperature	73	°C
Intake air temperature	15	°C
Ambient air pressure	1010	mbar
Voltage terminal 30	14.92	V
Dynamic environmental data	20 96 28 11 CE 11 94 11 C8 11 AE 11 C9 F9 E4 11 A4 26 66 12 8A A2 15 9F 44 D4 15 A0 44 A4	
Unlearning counter according OBD	40	
Low fuel pressure, specified value	450.0	kPa
Fuel low pressure, actual value	452.6	kPa
Adaptation of Fuel Pump (FP)	-156.4	kPa
Fuel pump, specified value	14.99939	%
Fuel temperature	73.5	°C
Fuel high pressure, actual value	8.81	MPa
Fuel pressure rail 2	8.786	MPa

Figure 1

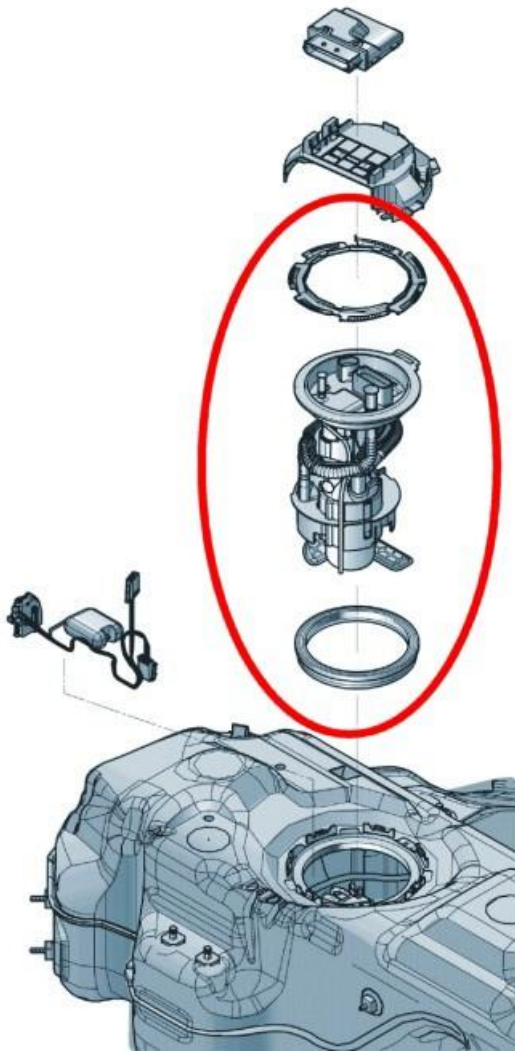

Figure 2

Measure 2 - Check Engine Lamp Illumination, Engine Running Concerns, Fuel System and Misfire DTC's

With symptoms of "Check Engine Lamp Illumination", "Poor Engine Running" accompanied with one or more of the following DTC's:

- "P310B00 Low Fuel Pressure Regulation"
- "P014800 Fuel Deliver Error"
- "Misfire" DTC's

Check "Low fuel pressure, specified value" and "Fuel low pressure, actual value" within the fault memory, refer to ECU "01 – Engine Control Module 1" - From "Extended ambient conditions" note the values of the "Low fuel pressure, specified value" and "Fuel low pressure, actual value" – figure 3.

Address: 0001 System name: 01 - Engine Control Module 1 Protocol variant: UDS/ISOTP (Ereignisse: 7)

+ Identification:

- Event memory entries (Data source: Vehicle):

Entry in fault memory

Number: P310B00: Low Fuel Pressure regulation Fuel pressure outside specification
 Fault type 2: passive/sporadic
 Symptom: 2636
 Status: 01100000

+ Standard ambient conditions:

- Extended ambient conditions:

Engine speed	1682.0	1/min
Normed load value	0.0	%
Vehicle speed	116	km/h
Coolant temperature	98	°C
Intake air temperature	17	°C
Ambient air pressure	1000	mbar
Voltage terminal 30	13.04	V

Dynamic environmental data
 20 96 24 11 CE 15 7C 11 C8 0F 05 11 C9
 01 12 11 A4 3A F2 12 8A B8 15 9F 80 D8
 15 A0 81 D0

Unlearning counter according OBD

Low fuel pressure, specified value	550.0	kPa
Fuel low pressure, actual value	384.5	kPa
Adaptation of Fuel Pump (FP)	27.4	kPa
Fuel pump, specified value	23.025513	%
Fuel temperature	90.0	°C
Fuel high pressure, actual value	16.492	MPa
Fuel pressure rail 2	16.616	MPa

Entry in fault memory

Number: P014800: Fuel Delivery Error
 Fault type 2: active/static
 Symptom: 4178
 Status: 11101101

+ Standard ambient conditions:

Figure 3

Next, if not already done, raise a DISS query, add the following results / information.

Note the "Low fuel pressure, specified value" and "Fuel low pressure, actual value" on the DISS query.

- Attach a current diagnostic log to the DISS query.
- Referencing the *Measurement* document attached, for each of the listed Electronic Control Units record the values listed, in addition, record all available fuel pressure measurements, add the completed list to the DISS query.
- Gather information on the Customer experience when the issue arose, such as, *Pre-conditions, warning lights and driveability at time issue occurred, when the vehicle was last refuelled.*
- Record fuel tank level.
- Using ODIS *Measured values* check low fuel pressure when the vehicle is starting or idling – this should normally be 400 – 800 kPa.
- Check the fuel system pressure at the fuel tank outlet with a pressure gauge, this should be the same as the figure measured with ODIS or approximately 100 kPa lower if the gauge is relative to atmospheric pressure.
- After switching the engine off the pressure within the fuel system should remain at 400 kPa or above for at least ten minutes.
- Check the fuel pump ECU electrical earth point condition, check for debris, cleanliness and tightness of earth point nut. Record results on the DISS query, attach clear photograph(s).
- Check all fuel pump ECU connector pins for signs of contamination or damage. Check for any other concern that may lead to poor retention, high resistance or poor connection. Ensure issues noted during this inspection are corrected, reconnect all removed connectors.
- Clear any fault codes that may be present and conduct a short road test, make a note of any fault codes that are logged during the road test.
- The DISS query should be second levelled, a review of all information should be carried out before next steps are advised.
- DISS guidance may advise further recording of fuel line check valve status/condition and replacement for analysis.

Warranty accounting instructions

Warranty type – 110 or 910

Damage Service Number – 2066

Damage Code – 0100

Labour Operation Codes -

01 50 00 00 - Self Diagnosis – Time taken from diagnostic log (Maximum 30TU)

20 66 19 50 - Electric Fuel Pump - Remove + Reinstall - 50TUs

70 49 19 01 - Rear Floor Covering - Remove + Reinstall - 300TUs

Parts information

For the latest part information always refer to the Electronic Parts Catalogue – ETKA.