

Subject: INTERFERENCE BETWEEN LIFTGATE AND REAR BUMPER	Bulletin No.: 09-032/20
	Last Issued: 09/25/2020

APPLICABLE MODEL(S)/VINS

2019-2021 Mazda3 5-door HB (Japan built) with VINS lower than JM1BP*****300046 (produced before June 17, 2020)

DESCRIPTION

Some vehicles may exhibit that the liftgate interferes with the rear bumper when closed forcefully, resulting in damaged paint on the rear bumper. Due to variations of the clearance between the liftgate and the rear bumper, the bottom edge of the liftgate may overrun the rear bumper. To correct this concern, the hardness of stop rubbers on the liftgate has been modified.

Customers having this concern should have their vehicle repaired using the following repair procedure.

REPAIR PROCEDURE

1. Verify customer concern.
2. Replace the stop rubbers with modified ones.

- (1) Rubber, Stop (Main)
(2) Rubber, Stop (Sub)

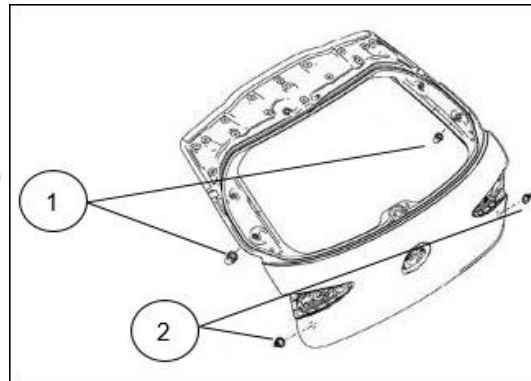

3. Verify repair.

CONSUMER NOTICE: The information and instructions in this bulletin are intended for use by skilled technicians. Mazda technicians utilize the proper tools/equipment and take training to correctly and safely maintain Mazda vehicles. These instructions should not be performed by "do-it-yourselfers." Customers should not assume this bulletin applies to their vehicle or that their vehicle will develop the described concern. To determine if the information applies, customers should contact their nearest authorized Mazda dealership. Mazda North American Operations reserves the right to alter the specifications and contents of this bulletin without obligation or advance notice. All rights reserved. No part of this bulletin may be reproduced in any form or by any means, electronic or mechanical---including photocopying and recording and the use of any kind of information storage and retrieval system ---without permission in writing.

NOTE: Explain the following to the customer when replacing the stop rubbers.

By changing to the harder rubber, the overrun allowance between the liftgate and the weatherstrip will be reduced and the interference will be prevented. As a result, the bounce when opening the liftgate will be stronger and the liftgate will need to be closed a little harder against the stop rubber. The bounce and tightness of closing the liftgate will be reduced gradually as time goes by.

PARTS INFORMATION

Parts Number	Description	Qty.	Notes
TK78-62-877A	Rubber, Stop	2	Main
KB7W-62-877C	Rubber, Stop	2	Sub

WARRANTY INFORMATION

NOTE:

- This warranty information applies only to verified customer complaints on vehicles eligible for warranty repair.
- This repair will be covered under Mazda's New Vehicle Limited Warranty term.
- Additional diagnostic time cannot be claimed for this repair.

Warranty Type	A
Symptom Code	90
Damage Code	9H
Part Number Main Cause	TK78-62-877A
Quantity	2
Operation Number / Labor Hours:	XXS46XRX / 0.2 Hrs.

NOTE:

- Enter KB7W-62-877C (Sub) as a related part number.
- If painting is required, claim it using sublet code "A1" and attach pictures of the damage.
- All paint sublet of \$1000 or higher must have prior authorization from MNAO Warranty.

CONSUMER NOTICE: The information and instructions in this bulletin are intended for use by skilled technicians. Mazda technicians utilize the proper tools/equipment and take training to correctly and safely maintain Mazda vehicles. These instructions should not be performed by "do-it-yourselfers." Customers should not assume this bulletin applies to their vehicle or that their vehicle will develop the described concern. To determine if the information applies, customers should contact their nearest authorized Mazda dealership. Mazda North American Operations reserves the right to alter the specifications and contents of this bulletin without obligation or advance notice. All rights reserved. No part of this bulletin may be reproduced in any form or by any means, electronic or mechanical---including photocopying and recording and the use of any kind of information storage and retrieval system ---without permission in writing.