



DETROITTM
DEMAND PERFORMANCESM

18SP736 – Heavy Duty Friction Style Belt Tensioner Kit Special Notice

KIT DESCRIPTION

This heavy duty friction style belt tensioner kit contains the belt tensioner and two M10 bolts to correctly pin the friction style belt tensioner. The M10x80mm bolt is used to pin the engine cooling fan drive arm. The M10x50mm bolt is used to pin the engine accessory drive arm.

KIT CONTENTS

Service kit P/N: A4722001570 contains all the necessary parts to replace and correctly pin the direct swap of the heavy duty friction style belt tensioner on units that are already equipped with the friction style tensioner.

Part No.	Qty.	Description
A4722001370	1	Belt Tensioner
N910105010016	1	Bolt M10 x 80 mm
N910105010002	1	Bolt M10 x 50 mm

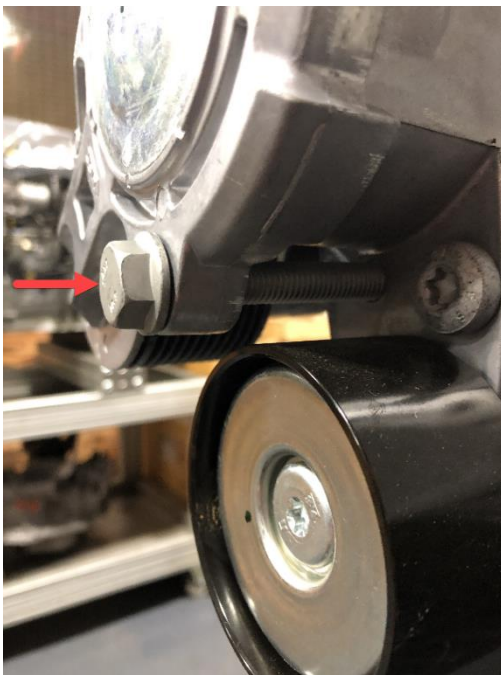

**Figure 1: Cooling Fan Arm Pinned
(M10x80 mm bolt)**



**Figure 2: Accessory Drive Arm Pinned
(M10x50 mm bolt)**

SPECIAL NOTICE:

This friction style belt tensioner kit does not include mounting bolts and should only be used on engines currently equipped with the friction style belt tensioner. Units currently equipped with the hydraulic style belt tensioner should refer to 18SP743 for the friction style belt tensioner retrofit kit and instructions. Refer to 20TS-03 for more details.

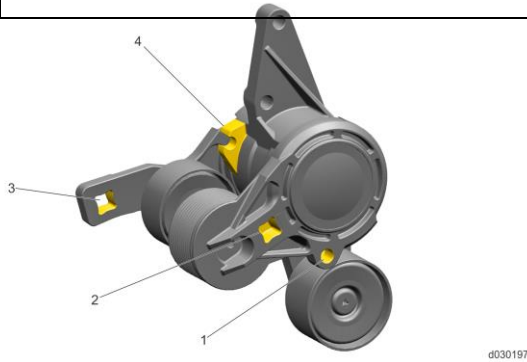

Figure 2: Friction Belt tensioner

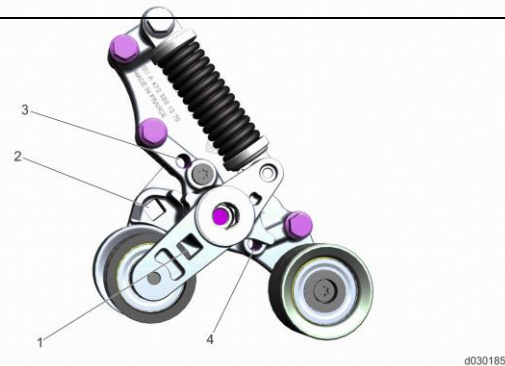

Figure 1: Hydraulic Belt Tensioner

SPECIAL NOTICE:

Poly-v-belts should always be replaced when a new belt tensioner is being installed. We recommend the use of belts specified by DTNA. Always refer to PartsPro on DTNAConnect.com for the latest belt part number information to avoid using the incorrect belt on a particular unit.



13400 Outer Drive, West, Detroit, Michigan 48239-4001
Telephone: 313-592-5000
DEMANDDETROIT.COM

Specifications are subject to change without notice. Detroit Diesel Corporation is registered to ISO 9001:2008. Copyright © Detroit Diesel Corporation. All rights reserved. Detroit™ is a brand of Detroit Diesel Corporation, a Daimler company.

18SP736 2009 As technical advances continue, specifications will change. Printed in U.S.A.