

**Complaint - Oil Leaks on Double Clutch Transmission (Porsche Doppelkupplung (PDK)):
Observe Specified Procedure (88/20)**

Model Line: **911 Carrera (992)**

Model Year: **As of 2020**

Equipment: **8-speed automatic transmission (I-no. G1F)
8-speed automatic transmission for all-wheel drive (I-no. G1G)**

Subject: **Double clutch transmission (PDK)**

Information: Oil leaks on double clutch transmission.

Remedial Action: Find oil leaks and carry out the relevant repair measure.

- Contents:
- Preparatory work, see ⇒ *Technical Information 'Preparatory work'*
 - Leaks in the area (right side of transmission), see ⇒ *Technical Information 'Leaks in the area (right side of transmission)'*
 - Leaks in the area (left side of transmission), see ⇒ *Technical Information 'Leaks in the area (left side of transmission)'*
 - Leaks in the area (upper side of transmission), see ⇒ *Technical Information 'Leaks in the area (upper side of transmission)'*
 - Leaks in the area (lower side of transmission), see ⇒ *Technical Information 'Leaks in the area (lower side of transmission)'*
 - Leaks in the area (rear side of transmission), see ⇒ *Technical Information 'Leaks in the area (rear side of transmission)'*
 - Leaks in the area (front side of transmission), see ⇒ *Technical Information 'Leaks in the area (front side of transmission)'*
 - Concluding work, see ⇒ *Technical Information 'Concluding work'*

Preparatory work

Work Procedure:



Information

- Oil leaks must be clearly identifiable and reproducible
 - Engine oil and coolant must have reached operating temperature during a test drive
 - If oil is leaking from the final drive or hydraulic chamber breather, disconnect both hoses to find the exact location of the leak
- 1 Remove rear cover, see ⇒ *Workshop Manual '519419 Removing and installing rear cover'*.

- 2 Take photos of the problem for PQIS.
- 3 Clean the transmission.
- 4 Spray possible leak points with leak-locating spray.
- 5 Perform a test drive.
- 6 Find oil leaks.
- 7 Take photos of the leak points found for PQIS.

Leaks in the area (right side of transmission)

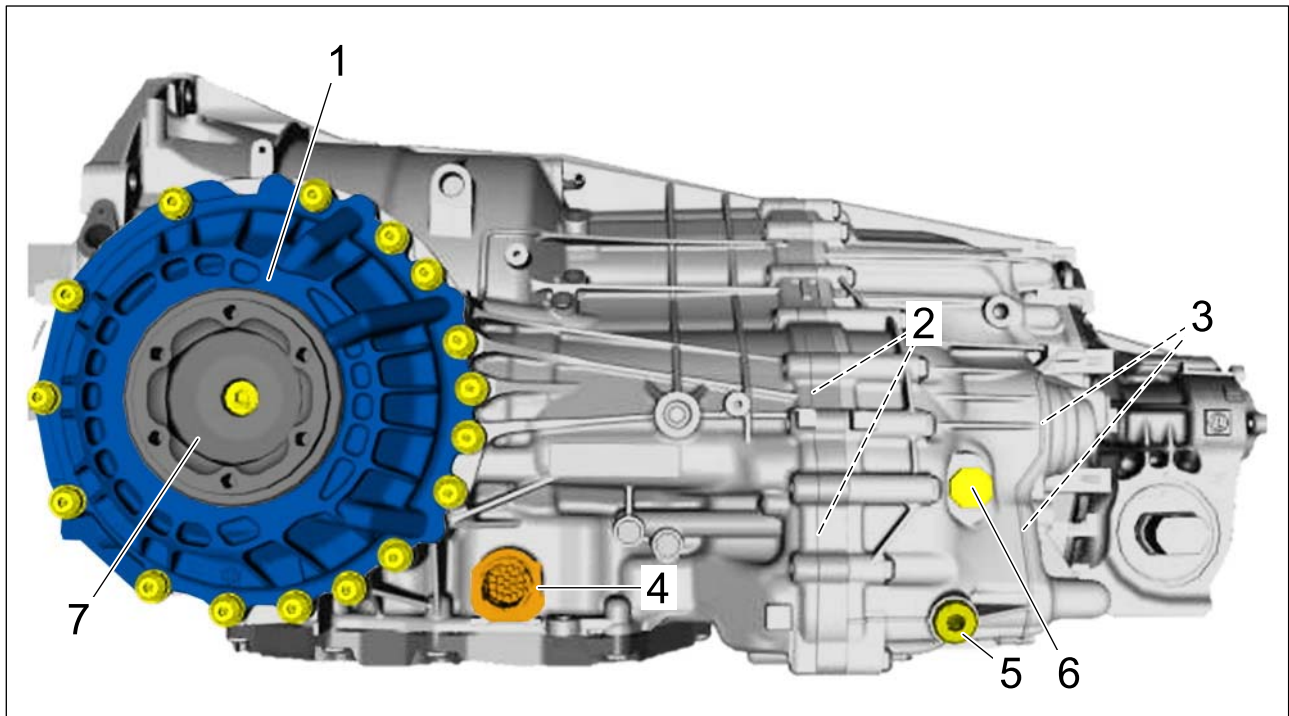

Right side of transmission

Position	Leak area	Possible cause(s)	Repair measure
⇒ Right side of transmission-1-	Differential cover 1A - 1C	Sealing ring damaged (A)	Replace sealing ring, see ⇒ <i>Workshop Manual '391555 Replacing flanged-shaft sealing ring'.</i>
		Screw loose (B)	Replace screws, see ⇒ <i>Workshop Manual '391555 Replacing flanged-shaft sealing ring'.</i>
		O-ring damaged (C)	Replace O-ring, see ⇒ <i>Workshop Manual '391555 Replacing flanged-shaft sealing ring'.</i>
⇒ Right side of transmission-2-	Rear transmission housing seal 2A - 2B	Screw loose (A)	Replace double clutch transmission, see ⇒ <i>Workshop Manual '373419 Removing and installing double clutch transmission'.</i>
		Seal damaged (B)	
⇒ Right side of transmission-3-	Front transmission housing seal 3A - 3B	Screw loose (A)	Replace double clutch transmission, see ⇒ <i>Workshop Manual '373419 Removing and installing double clutch transmission'.</i>
		Seal damaged (B)	
⇒ Right side of transmission-4-	Central connector at the left 4A - 4B	Sealing ring damaged (A)	Replace wire harness, see ⇒ <i>Workshop Manual '387719 Removing and installing transmission control mechanism'.</i> Tighten screws to 3 Nm (2 ftlb.).
		Connector leaking (B)	
⇒ Right side of transmission-5-	Screw plug	Sealing ring damaged	Replace screw and tighten to 27 Nm (20 ftlb.). Re-use spring and sleeve during installation.
⇒ Right side of transmission-6-	Oil filler screw	Sealing ring damaged	Replace screw and tighten to 27 Nm (20 ftlb.).
⇒ Right side of transmission-7-	Right halfshaft flange 7A - 7C	Sealing ring damaged (A)	Replace sealing ring, see ⇒ <i>Workshop Manual '392255 Workshop Manual '392255 Replacing sealing ring for right halfshaft flange - double clutch transmission'.</i>
		Right halfshaft flange damaged (B)	Replace halfshaft flange, see ⇒ <i>Workshop Manual '392519 Workshop Manual '392519 Removing and installing right halfshaft flange - double clutch transmission'.</i>

		Screw loose, leaking (C)	Replace screw, see ⇒ <i>Workshop Manual '392519 Workshop Manual '392519 Removing and installing right halfshaft flange - double clutch transmission'.</i>
--	--	--------------------------	---

Parts Info (1A - 1C): **Parts required** (for differential cover):

Part No.	Designation - Use	Qty.
ODT301179	⇒ Sealing ring - Differential housing cover	1 ea.
ODT301225	⇒ O-ring - Differential housing cover	3 ea.
xxx	⇒ Aluminium screw, M8 x 25 - Differential housing cover	16 ea.
ODT311152	⇒ Circlip - Flanged shaft	1 ea.
PAF009145	⇒ Internal hexagon round-head bolt with O-ring - Flanged shaft	1 ea.
WHT008727	⇒ Cheese head bolt - Drive shaft	12 ea.
9A740735700	⇒ Plate - Drive shaft	6 ea.
PAF008673	⇒ Hexagon-head bolt - Rear axle carrier	2 ea.
PAF008735	⇒ Hexagon-head bolt - Rear axle carrier	2 ea.
WHT007957	⇒ Hexagon self-clinching nut - Connecting link	2 ea.
	or	
9A700781900	⇒ Hexagon nut - Connecting link (PDCC)	2 ea.
PAF909664	⇒ Hexagon collar nut - Lower trailing arm	2 ea.
PAF008674	⇒ Hexagon flange bolt - Lower trailing arm	2 ea.
WHT008676	⇒ Hexagon-head bolt - Strut	4 ea.

ODT321176	⇒ Shaft sealing ring – Flanged shaft	1 ea.
ODT321243	⇒ Shaft sealing ring – Flanged shaft	1 ea.
Also use for all-wheel drive		
PAF911439	⇒ Cheese head bolt – Cardan shaft	4 ea.

Invoicing (1A - 1C): For documentation and warranty invoicing, enter the labor operations, PQIS coding and relevant part numbers specified below in the warranty claim:

APOS	Labour operation	I No.
39155556	Replacing flanged-shaft sealing ring	
37341905	Removing and installing double clutch transmission (Coupé, without PDCC)	
37341907	Removing and installing double clutch transmission (Coupé, with PDCC)	
37341915	Removing and installing double clutch transmission (Targa/Cabriolet, without PDCC)	
37341917	Removing and installing double clutch transmission (Targa/Cabriolet, with PDCC)	

Choose PQIS coding based on the cause defined above:

1A – 1C

Fault location (FES5)	39200	Cover for final drive
Damage category (SA4)	3013	Damaged

Parts Info (2A - 2B): **Parts required** (for rear transmission housing seal):

Part No.	Designation – Use	Qty.
ODT300041BX	⇒ Transmission (I-no. G1F)	1 ea.
	or	
ODT300043BX	⇒ Transmission with differential lock (I-no. G1F)	1 ea.
	or	
ODT300061BX	⇒ Transmission (I-no. G1G)	1 ea.
	or	

ODT300063BX	⇒ Transmission with differential lock (I-no. G1G)	1 ea.
Additional parts required		
WHT008727	⇒ Cheese head bolt – Drive shaft	12 ea.
9A740735700	⇒ Plate – Drive shaft	6 ea.
PAF008673	⇒ Hexagon-head bolt – Rear axle carrier	2 ea.
PAF008735	⇒ Hexagon-head bolt – Rear axle carrier	2 ea.
WHT007957	⇒ Hexagon self-clinching nut – Connecting link	2 ea.
or		
9A700781900	⇒ Hexagon nut – Connecting link (PDCC)	2 ea.
PAF909664	⇒ Hexagon collar nut – Lower trailing arm	2 ea.
PAF008674	⇒ Hexagon flange bolt – Lower trailing arm	2 ea.
WHT008676	⇒ Hexagon-head bolt – Strut	4 ea.
Also use for all-wheel drive		
PAF911439	⇒ Cheese head bolt – Cardan shaft	4 ea.

Invoicing (2A - 2B): For documentation and warranty invoicing, enter the labor operations, PQIS coding and relevant part numbers specified below in the warranty claim:

APOS	Labour operation	I No.
37341905	Removing and installing double clutch transmission (Coupé, without PDCC)	
37341907	Removing and installing double clutch transmission (Coupé, with PDCC)	
37341915	Removing and installing double clutch transmission (Targa/Cabriolet, without PDCC)	
37341917	Removing and installing double clutch transmission (Targa/Cabriolet, with PDCC)	

PQIS coding:

Location (FES5)	37500	Seal
Damage type (SA4)	1817	Loose

Parts Info (3A - 3B): **Parts required** (for front transmission housing seal):

Part No.	Designation - Use	Qty.
ODT300041BX	⇒ Transmission (I-no. G1F)	1 ea.
	or	
ODT300043BX	⇒ Transmission with differential lock (I-no. G1F)	1 ea.
	or	
ODT300061BX	⇒ Transmission (I-no. G1G)	1 ea.
	or	
ODT300063BX	⇒ Transmission with differential lock (I-no. G1G)	1 ea.
	Additional parts required	
WHT008727	⇒ Cheese head bolt - Drive shaft	12 ea.
9A740735700	⇒ Plate - Drive shaft	6 ea.
PAF008673	⇒ Hexagon-head bolt - Rear axle carrier	2 ea.
PAF008735	⇒ Hexagon-head bolt - Rear axle carrier	2 ea.
WHT007957	⇒ Hexagon self-clinching nut - Connecting link	2 ea.
	or	
9A700781900	⇒ Hexagon nut - Connecting link (PDCC)	2 ea.
PAF909664	⇒ Hexagon collar nut - Lower trailing arm	2 ea.
PAF008674	⇒ Hexagon flange bolt - Lower trailing arm	2 ea.
WHT008676	⇒ Hexagon-head bolt - Strut	4 ea.

Also use for all-wheel drive

PAF911439 ⇒ Cheese head bolt 4 ea.
– Cardan shaft

Invoicing (3A - 3B): For documentation and warranty invoicing, enter the labor operations, PQIS coding and relevant part numbers specified below in the warranty claim:

APOS	Labour operation	I No.
37341905	Removing and installing double clutch transmission (Coupé, without PDCC)	
37341907	Removing and installing double clutch transmission (Coupé, with PDCC)	
37341915	Removing and installing double clutch transmission (Targa/Cabriolet, without PDCC)	
37341917	Removing and installing double clutch transmission (Targa/Cabriolet, with PDCC)	

PQIS coding:

Location (FES5)	37343	Gear housing seal
Damage type (SA4)	3024	Porous

Parts Info and Materials (4A - 4B): **Parts required** (for left central connector):

Part No.	Designation – Use	Qty.
ODT907998	⇒ Wire harness – Transmission control mechanism	1 ea.
	or	
ODT907998A	⇒ Wire harness – Transmission control mechanism (differential lock)	1 ea.
	Additional parts required	
PAF009391	⇒ Torx screw – Transmission control mechanism	24 ea.
ODT317165	⇒ Transmission oil pan	1 ea.
PAF009388	⇒ Internal hexagon round-head bolt – Transmission oil pan	13 ea.

Required materials (usually already available at the Porsche dealer):

Part No.	Designation	Qty.
00004321044	⇒ Transmission oil	20-liter/ 5.28 gallon container ¹⁾

¹⁾ approx. 6 liter/ 1.58 gallon required per vehicle.

Invoicing (4A - 4B): For documentation and warranty invoicing, enter the labor operations, PQIS coding and relevant part numbers specified below in the warranty claim:

APOS	Labour operation	I No.
38774950	Reworking transmission control mechanism	

PQIS coding:

Location (FES5)	37370	Transmission housing
Damage type (SA4)	1817	Loose

Parts Info (5): **Parts required** (for screw plug):

Part No.	Designation	Qty.
PAF008528	⇒ Screw plug with sealing ring	1 ea.

Invoicing (5): For documentation and warranty invoicing, enter the labor operations, PQIS coding and relevant part numbers specified below in the warranty claim:

APOS	Labour operation	I No.
34571950	Removing and installing oil drain plug	

PQIS coding:

Location (FES5)	34570	Oil drain plug
Damage type (SA4)	1817	Loose

Parts Info (6): **Parts required** (for oil filler screw):

Part No.	Designation	Qty.
PAF008528	⇒ Screw plug with sealing ring	1 ea.

Invoicing (6): For documentation and warranty invoicing, enter the labor operations, PQIS coding and relevant part numbers specified below in the warranty claim:

APOS	Labour operation	I No.
37374951	Reworking transmission housing	

PQIS coding:

Location (FES5)	37370	Transmission housing
Damage type (SA4)	1817	Loose

Parts Info (7A): **Required parts:**

Part No.	Designation - Use	Qty.
ODT321243	⇒ Shaft sealing ring Right halfshaft flange	1 ea.
PAF009145	⇒ Internal hexagon round-head bolt with O-ring - Right halfshaft flange	1 ea.
WHT008676	⇒ Hexagon-head bolt - Right strut	2 ea.
WHT008727	⇒ Cheese head bolt - Drive shaft	6 ea.
9A740735700	⇒ Plate - Drive shaft	3 ea.

Parts Info (7B): **Required parts:**

Part No.	Designation - Use	Qty.
ODT323662	⇒ Flanged shaft - Right halfshaft flange	1 ea.
ODT321243	⇒ Shaft sealing ring Right halfshaft flange	1 ea.
PAF009145	⇒ Internal hexagon round-head bolt with O-ring - Right halfshaft flange	1 ea.
WHT008676	⇒ Hexagon-head bolt - Right strut	2 ea.
WHT008727	⇒ Cheese head bolt - Drive shaft	6 ea.
9A740735700	⇒ Plate - Drive shaft	3 ea.

Parts Info (7C): **Required parts:**

Part No.	Designation - Use	Qty.
PAF009145	⇒ Internal hexagon round-head bolt with O-ring - Right halfshaft flange	1 ea.
WHT008676	⇒ Hexagon-head bolt - Right strut	2 ea.
WHT008727	⇒ Cheese head bolt - Drive shaft	6 ea.
9A740735700	⇒ Plate - Drive shaft	3 ea.

Invoicing (7A - 7C): For documentation and warranty invoicing, enter the labor operations, PQIS coding and relevant part numbers specified below in the warranty claim:

APOS	Labour operation	I No.
39254150	Repairing halfshaft flange	
39225552	Replacing sealing ring for halfshaft flange	

Choose PQIS coding based on the cause defined above:

7A - 7C

Fault location (FES5)	39251	Flanged shaft mount, left
Damage category (SA4)	1817	Loose

Leaks in the area (left side of transmission)

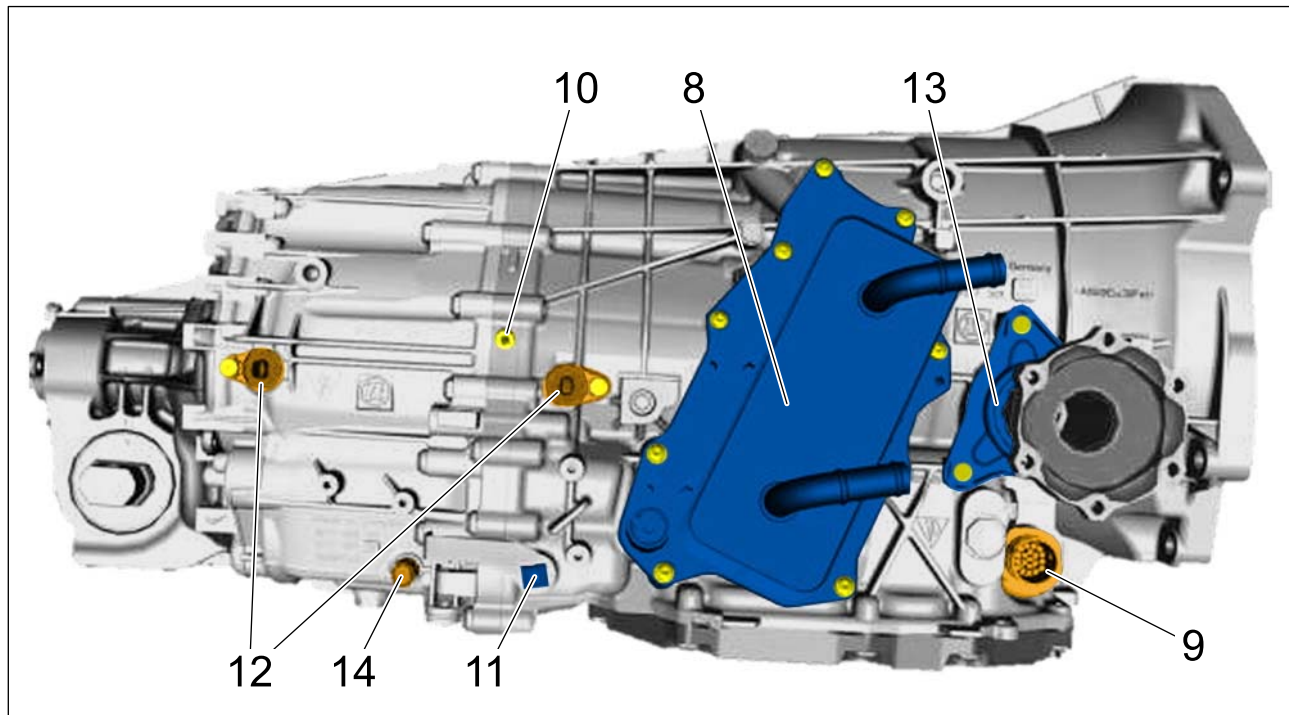

Left side of transmission (with ATF cooler)

Position	Oil leak	Possible cause(s)	Repair measure
⇒ Left side of transmission (with ATF cooler) -8-	ATF cooler 8A - 8C	Screw loose (A)	Replace screw, see ⇒ <i>Workshop Manual '377219 Removing and installing transmission oil cooler'</i> .
	If there are oil leaks in the ATF cooler area, see also ⇒ Left side of transmission (without ATF cooler) -15 - 16-. ⇒ Left side of transmission (with ATF cooler) -8-	Seal damaged (B)	Replace seal, see ⇒ <i>Workshop Manual '377219 Removing and installing transmission oil cooler'</i> .
		ATF cooler leaking (C)	Replace ATF cooler, see ⇒ <i>Workshop Manual '377219 Removing and installing transmission oil cooler'</i> .
⇒ Left side of transmission (with ATF cooler) -9-	Central connector at the right 9A - 9B	Sealing ring damaged (A)	Replace double clutch transmission, see ⇒ <i>Workshop Manual '373419 Removing and installing double clutch transmission'</i> .
		Connector leaking (B)	

⇒ Left side of transmission (with ATF cooler) -10-	Bleeder screw	Shaft sealing ring damaged	Replace double clutch transmission, see ⇒ Workshop Manual '373419 Removing and installing double clutch transmission'.
⇒ Left side of transmission (with ATF cooler) -11-	Selector shaft	Sealing ring damaged	Replace sealing ring, see ⇒ Workshop Manual '373355 Replacing selector shaft sealing ring'.
⇒ Left side of transmission (with ATF cooler) -12-	rpm sensor 12A - 12B	Sealing ring damaged (A)	Replace sealing ring.
		Screw loose (B)	Replace screw and tighten to 3.2 Nm (2.2 ftlb.) and a final tightening torque angle of 30°.
⇒ Left side of transmission (with ATF cooler) -13-	Left halfshaft flange	Grease leak on bearing	Replace bearing, see ⇒ Workshop Manual '392555 Replacing left halfshaft flange bearing'.
⇒ Left side of transmission (with ATF cooler) -14-	Temperature sensor 14A - 14B	Sealing ring damaged (A)	Replace temperature sensor, see ⇒ Workshop Manual '377419 Removing and installing transmission oil temperature sensor'.
		Connector leaking (B)	

Parts Info and Materials (8A):

Parts required (for ATF cooler):

Part No.	Designation - Use	Qty.
PAF009496	⇒ Internal hexagon round-head countersunk screw - ATF cooler	9 ea.
PAF009390	⇒ Screw plug with sealing ring	1 ea.
PAF008528	⇒ Screw plug with sealing ring	1 ea.
WHT008676	⇒ Hexagon-head bolt - Strut	4 ea.

Required materials (usually already available at the Porsche dealer):

Part No.	Designation	Qty.
00004321044	⇒ Transmission oil	20-liter/ 5.28 gallon container ¹⁾

¹⁾ approx. 6 liter/ 1.58 gallon required per vehicle.

Parts Info and Materials (8B): **Parts required** (for ATF cooler):

Part No.	Designation – Use	Qty.
PAF009496	⇒ Internal hexagon round-head countersunk screw – ATF cooler	9 ea.
ODT301461	⇒ Seal – ATF cooler	1 ea.
PAF009390	⇒ Screw plug with sealing ring	1 ea.
PAF008528	⇒ Screw plug with sealing ring	1 ea.
WHT008676	⇒ Hexagon-head bolt – Strut	4 ea.

Required materials (usually already available at the Porsche dealer):

Part No.	Designation	Qty.
00004321044	⇒ Transmission oil	20-liter/ 5.28 gallon container ¹⁾

¹⁾ approx. 6 liter/ 1.58 gallon required per vehicle.

Parts Info and Materials (8C): **Parts required** (for ATF cooler):

Part No.	Designation – Use	Qty.
PAF009496	⇒ Internal hexagon round-head countersunk screw – ATF cooler	9 ea.
ODT301461	⇒ Seal – ATF cooler	1 ea.
ODT300333	⇒ Heat exchanger	1 ea.
PAF009390	⇒ Screw plug with sealing ring	1 ea.

PAF008528	⇒ Screw plug with sealing ring	1 ea.
WHT008676	⇒ Hexagon-head bolt - Strut	4 ea.

Required materials (usually already available at the Porsche dealer):

Part No.	Designation	Qty.
00004321044	⇒ Transmission oil	20-liter/ 5.28 gallon container ¹⁾

¹⁾ approx. 6 liter/ 1.58 gallon required per vehicle.

Invoicing (8A - 8C): For documentation and warranty invoicing, enter the labor operations, PQIS coding and relevant part numbers specified below in the warranty claim:

APOS	Labour operation	I No.
37724950	Reworking oil cooler (8A)	
37721950	Removing and installing oil cooler (without PDCC) (8B - 8C)	
37721952	Removing and installing oil cooler (with PDCC) (8B - 8C)	

Choose PQIS coding based on the cause defined above:

8A – 8C

Fault location (FES5)	38600	ATF cooler
Damage category (SA4)	1817	Loose

Parts Info (9A - 9B): **Parts required** (for central connector at the right):

Part No.	Designation - Use	Qty.
ODT300041BX	⇒ Transmission (I-no. G1F)	1 ea.
	or	
ODT300043BX	⇒ Transmission with differential lock (I-no. G1F)	1 ea.
	or	
ODT300061BX	⇒ Transmission (I-no. G1G)	1 ea.
	or	

ODT300063BX	⇒ Transmission with differential lock (I-no. G1G)	1 ea.
Additional parts required		
WHT008727	⇒ Cheese head bolt – Drive shaft	12 ea.
9A740735700	⇒ Plate – Drive shaft	6 ea.
PAF008673	⇒ Hexagon-head bolt – Rear axle carrier	2 ea.
PAF008735	⇒ Hexagon-head bolt – Rear axle carrier	2 ea.
WHT007957	⇒ Hexagon self-clinching nut – Connecting link	2 ea.
or		
9A700781900	⇒ Hexagon nut – Connecting link (PDCC)	2 ea.
PAF909664	⇒ Hexagon collar nut – Lower trailing arm	2 ea.
PAF008674	⇒ Hexagon flange bolt – Lower trailing arm	2 ea.
WHT008676	⇒ Hexagon-head bolt – Strut	4 ea.
Also use for all-wheel drive		
PAF911439	⇒ Cheese head bolt – Cardan shaft	4 ea.

Invoicing (9A - 9B): For documentation and warranty invoicing, enter the labor operations, PQIS coding and relevant part numbers specified below in the warranty claim:

APOS	Labour operation	I No.
37341905	Removing and installing double clutch transmission (Coupé, without PDCC)	
37341907	Removing and installing double clutch transmission (Coupé, with PDCC)	
37341915	Removing and installing double clutch transmission (Targa/Cabriolet, without PDCC)	
37341917	Removing and installing double clutch transmission (Targa/Cabriolet, with PDCC)	

PQIS coding:

Location (FES5)	37340	Double clutch transmission
Damage type (SA4)	2031	Oil consumption too high

Parts Info (10): **Parts required** (for bleeder screw):

Part No.	Designation - Use	Qty.
ODT300041BX	⇒ Transmission (I-no. G1F)	1 ea.
	or	
ODT300043BX	⇒ Transmission with differential lock (I-no. G1F)	1 ea.
	or	
ODT300061BX	⇒ Transmission (I-no. G1G)	1 ea.
	or	
ODT300063BX	⇒ Transmission with differential lock (I-no. G1G)	1 ea.
	Additional parts required	
WHT008727	⇒ Cheese head bolt - Drive shaft	12 ea.
9A740735700	⇒ Plate - Drive shaft	6 ea.
PAF008673	⇒ Hexagon-head bolt - Rear axle carrier	2 ea.
PAF008735	⇒ Hexagon-head bolt - Rear axle carrier	2 ea.
WHT007957	⇒ Hexagon self-clinching nut - Connecting link	2 ea.
	or	
9A700781900	⇒ Hexagon nut - Connecting link (PDCC)	2 ea.
PAF909664	⇒ Hexagon collar nut - Lower trailing arm	2 ea.
PAF008674	⇒ Hexagon flange bolt - Lower trailing arm	2 ea.
WHT008676	⇒ Hexagon-head bolt - Strut	4 ea.

Also use for all-wheel drive

PAF911439 ⇒ Cheese head bolt 4 ea.
– Cardan shaft

Invoicing (10): For documentation and warranty invoicing, enter the labor operations, PQIS coding and relevant part numbers specified below in the warranty claim:

APOS	Labour operation	I No.
37341905	Removing and installing double clutch transmission (Coupé, without PDCC)	
37341907	Removing and installing double clutch transmission (Coupé, with PDCC)	
37341915	Removing and installing double clutch transmission (Targa/Cabriolet, without PDCC)	
37341917	Removing and installing double clutch transmission (Targa/Cabriolet, with PDCC)	

PQIS coding:

Location (FES5)	37370	Transmission housing
Damage type (SA4)	1817	Loose

Parts Info (11): **Parts required** (for selector shaft):

Part No.	Designation – Use	Qty.
9A700851800	⇒ Shaft sealing ring – Selector shaft	1 ea.

Invoicing (11): For documentation and warranty invoicing, enter the labor operations, PQIS coding and relevant part numbers specified below in the warranty claim:

APOS	Labour operation	I No.
37335555	Replacing sealing ring for selector shaft	

PQIS coding:

Location (FES5)	37370	Transmission housing
Damage type (SA4)	1817	Loose

Parts Info (12A - **Parts required** (for rpm sensor):
12B):

Part No.	Designation - Use	Qty.
9A7906401	⇒ rpm sensor	1 ea.
9A700855200	⇒ Round head screw - Rpm sensor	1 ea.

Invoicing (12): For documentation and warranty invoicing, enter the labor operations, PQIS coding and relevant part numbers specified below in the warranty claim:

APOS	Labour operation	I No.
38174151	Repairing inductive pickup (N1, left)	
38174152	Repairing inductive pickup (N2, right)	

Choose PQIS coding based on the cause defined above:

12A – 12B

Fault location (FES5)	38170	Inductive pickup
Damage category (SA4)	1511	Break

Parts Info (13): **Parts required** (for left halfshaft flange):

Part No.	Designation - Use	Qty.
ODT307125	⇒ Ball bearing - Left halfshaft flange	1 ea.
9A740735700	⇒ Plate - Left drive shaft	3 ea.
WHT008727	⇒ Cheese head bolt - Left drive shaft	6 ea.
WHT008676	⇒ Hexagon-head bolt - Left strut	2 ea.

Invoicing (13): For documentation and warranty invoicing, enter the labor operations, PQIS coding and relevant part numbers specified below in the warranty claim:

APOS	Labour operation	I No.
39254150	Repairing halfshaft flange	

PQIS coding:

Location (FES5)	39230	Bearing ring/lid seal
Damage type (SA4)	3024	Porous

Parts Info and Materials (14A - 14B): **Parts required** (for temperature sensor):

Part No.	Designation	Qty.
9A7906529A	⇒ Temperature sensor	1 ea.
PAF009390	⇒ Screw plug with sealing ring	1 ea.
PAF008528	⇒ Screw plug with sealing ring	1 ea.

Required materials (usually already available at the Porsche dealer):

Part No.	Designation	Qty.
00004321044	⇒ Transmission oil	20-liter/ 5.28 gallon container ¹⁾

¹⁾ approx. 6 liter/ 1.58 gallon required per vehicle.

Invoicing (14A - 14B): For documentation and warranty invoicing, enter the labor operations, PQIS coding and relevant part numbers specified below in the warranty claim:

APOS	Labour operation	I No.
37741952	Removing and installing temperature sensor	

Choose PQIS coding based on the cause defined above:

14A - 14B

Fault location (FES5)	34780	Temperature sensor
Damage category (SA4)	1511	Break

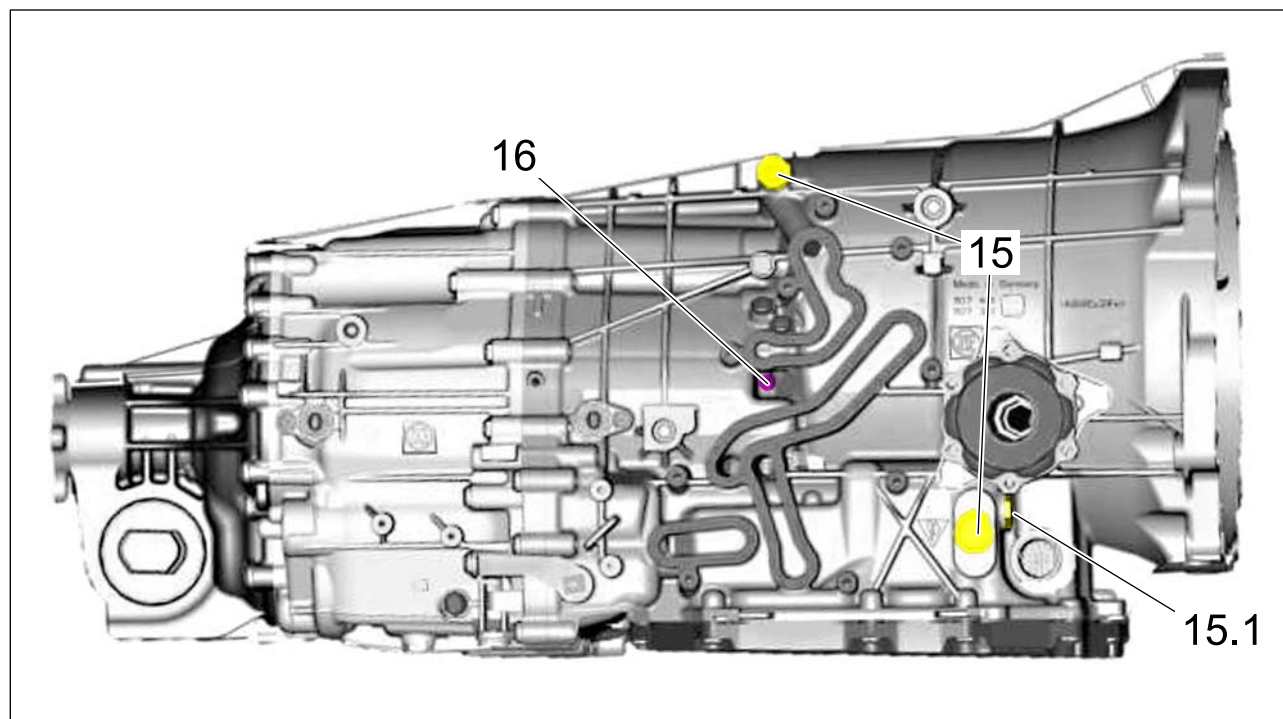

Left side of transmission (without ATF cooler)

Position	Oil leak	Cause	Repair measure
⇒ Left side of transmission (without ATF cooler) -15-	Screw plug 15A - 15B	Screw loose (A) Sealing ring damaged (B)	Replace screw and tighten to 27 Nm (20 ftlb.). Replace screw, see ⇒ Workshop Manual '370235 Checking and topping up ATF'.
	Oil filler screw 15C - 15D	Screw loose (C) Sealing ring damaged (D)	
⇒ Left side of transmission (without ATF cooler) -15.1-	Screw plug 15.1A - 15.1B	Screw loose (A) Sealing ring damaged (B)	Replace screw and tighten to 27 Nm (20 ftlb.).
⇒ Left side of transmission (without ATF cooler) -16-	Oil chamber partition If there are oil leaks in this area, see also ⇒ Left side of transmission (with ATF cooler) -8- and ⇒ Left side of transmission (without ATF cooler) -15 / 15.1-.	Shaft sealing ring damaged	Check the area using an endoscope. Replace double clutch transmission if there are leaks, see ⇒ Workshop Manual '373419 Removing and installing double clutch transmission'.

**Information**

If there is a leak around item 16, observe the specified procedure.

- Clean oil leak bore area and coat it directly with leak-locating spray
- Correct the oil level
- Perform a test drive
- Visually inspect the leak area of the oil leak bore

If the fault can be reproduced, the double clutch transmission must be replaced. If not, continue fault finding.

Parts Info (15): **Parts required** (for screw plug/oil filler screw):

Part No.	Designation	Qty.
PAF008528	⇒ Screw plug with sealing ring	1 ea.

Invoicing (15A - 15D): For documentation and warranty invoicing, enter the labor operations, PQIS coding and relevant part numbers specified below in the warranty claim:

APOS	Labour operation	I No.
37374952	Reworking transmission housing (screw plug)	
37374953	Reworking transmission housing (oil filler screw)	

PQIS coding:

Location (FES5)	37370	Transmission housing
Damage type (SA4)	1511	Break

Parts Info **Parts required** (for screw plug):

(15.1A -
15.1B):

Part No.	Designation	Qty.
PAF008528	⇒ Screw plug with sealing ring	1 ea.

Invoicing (15.1A - 15.1B) For documentation and warranty invoicing, enter the labor operations, PQIS coding and relevant part numbers specified below in the warranty claim:

APOS	Labour operation	I No.
37374954	Reworking transmission housing	

PQIS coding:

Location (FES5)	37370	Transmission housing
Damage type (SA4)	1511	Break

Parts Info (16): **Parts required** (for oil chamber partition):

Part No.	Designation - Use	Qty.
ODT300041BX	⇒ Transmission (I-no. G1F)	1 ea.
	or	
ODT300043BX	⇒ Transmission with differential lock (I-no. G1F)	1 ea.
	or	
ODT300061BX	⇒ Transmission (I-no. G1G)	1 ea.
	or	
ODT300063BX	⇒ Transmission with differential lock (I-no. G1G)	1 ea.
	Additional parts required	
WHT008727	⇒ Cheese head bolt - Drive shaft	12 ea.
9A740735700	⇒ Plate - Drive shaft	6 ea.
PAF008673	⇒ Hexagon-head bolt - Rear axle carrier	2 ea.
PAF008735	⇒ Hexagon-head bolt - Rear axle carrier	2 ea.
WHT007957	⇒ Hexagon self-clinching nut - Connecting link	2 ea.
	or	
9A700781900	⇒ Hexagon nut - Connecting link (PDCC)	2 ea.
PAF909664	⇒ Hexagon collar nut - Lower trailing arm	2 ea.
PAF008674	⇒ Hexagon flange bolt - Lower trailing arm	2 ea.
WHT008676	⇒ Hexagon-head bolt - Strut	4 ea.

Also use for all-wheel drive

PAF911439

⇒ Cheese head bolt
– Cardan shaft

4 ea.

Invoicing (16): For documentation and warranty invoicing, enter the labor operations, PQIS coding and relevant part numbers specified below in the warranty claim:

APOS	Labour operation	I No.
37341905	Removing and installing double clutch transmission (Coupé, without PDCC)	
37341907	Removing and installing double clutch transmission (Coupé, with PDCC)	
37341915	Removing and installing double clutch transmission (Targa/Cabriolet, without PDCC)	
37341917	Removing and installing double clutch transmission (Targa/Cabriolet, with PDCC)	

PQIS coding:

Location (FES5)	37370	Transmission housing
Damage type (SA4)	1511	Break

Leaks in the area (upper side of transmission)

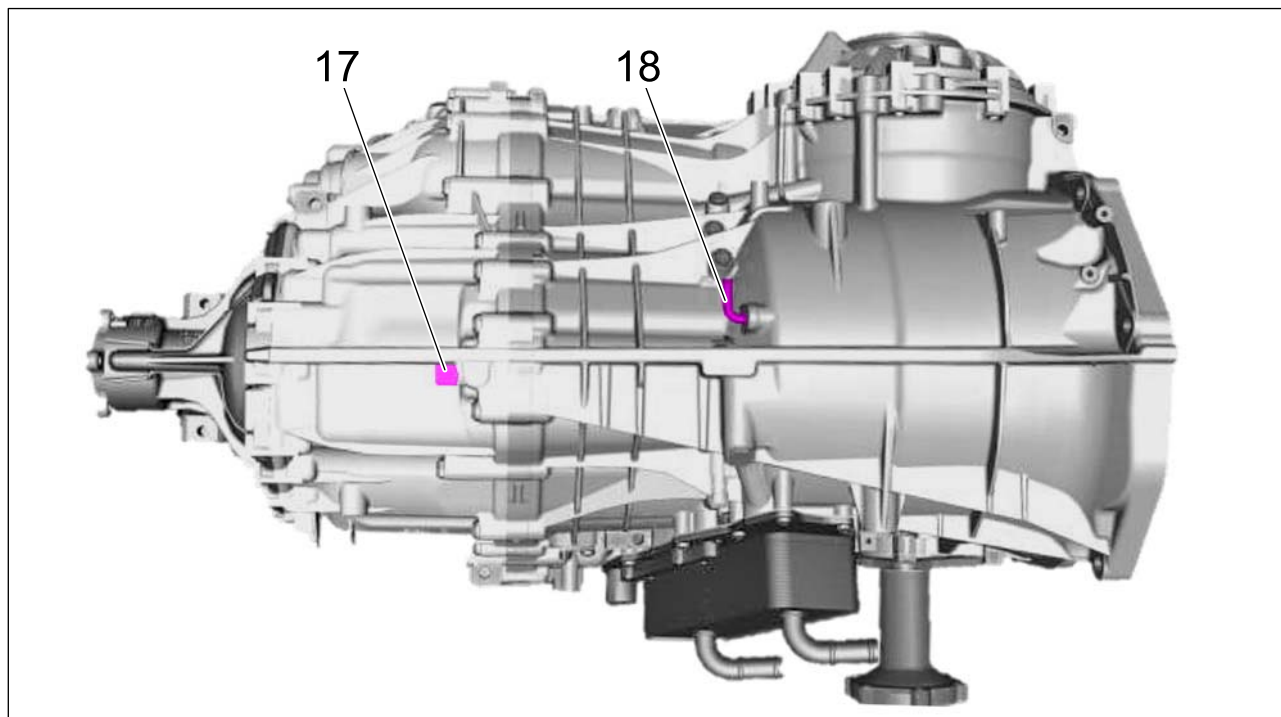

Upper side of transmission

Position	Oil leak	Cause	Repair measure
⇒ Upper side of transmission -17-	Hydraulic chamber breather 17A - 17B	Oil over-filled (A)	Check oil level of hydraulic chamber and final drive, see ⇒ <i>Technical Information '373419 Concluding work'</i> . Oil level in hydraulic chamber too high and final drive OK: Correct the oil level. Oil level in hydraulic chamber clearly too high and final drive too low: Replace double clutch transmission, see ⇒ <i>Workshop Manual '373419 Removing and installing double clutch transmission'</i> .
		Insufficient defoamer (B)	Change ATF, see ⇒ <i>Workshop Manual '370255 Changing ATF'</i> .
⇒ Upper side of	Final drive breather	Oil over-filled	Check ATF and final drive oil level, see ⇒ <i>Technical Information '370255 Concluding work'</i> .

<i>trans- mission</i> -18-	Oil level in final drive too high and ATF OK: Correct the oil level. Oil level in final drive is clearly too high and ATF too low: Replace double clutch transmission, see ⇒ <i>Workshop Manual '373419 Removing and installing double clutch transmission'</i> .
--	--

Parts Info and Materials (17A-17B): **Parts required** (for hydraulic chamber breather):

Part No.	Designation – Use	Qty.
Parts required for checking oil level		
PAF009390	⇒ Screw plug with sealing ring	1 ea.
9A700852600	⇒ Screw plug with sealing ring	1 ea.
PAF008528	⇒ Screw plug with sealing ring	1 ea.
Parts required for replacing transmission		
ODT300041BX	⇒ Transmission (I-no. G1F)	1 ea.
or		
ODT300043BX	⇒ Transmission with differential lock (I-no. G1F)	1 ea.
or		
ODT300061BX	⇒ Transmission (I-no. G1G)	1 ea.
or		
ODT300063BX	⇒ Transmission with differential lock (I-no. G1G)	1 ea.
Additional parts required		
WHT008727	⇒ Cheese head bolt – Drive shaft	12 ea.
9A740735700	⇒ Plate – Drive shaft	6 ea.
PAF008673	⇒ Hexagon-head bolt – Rear axle carrier	2 ea.
PAF008735	⇒ Hexagon-head bolt – Rear axle carrier	2 ea.
WHT007957	⇒ Hexagon self-clinching nut – Connecting link	2 ea.

	or	
9A700781900	⇒ Hexagon nut – Connecting link (PDCC)	2 ea.
PAF909664	⇒ Hexagon collar nut – Lower trailing arm	2 ea.
PAF008674	⇒ Hexagon flange bolt – Lower trailing arm	2 ea.
WHT008676	⇒ Hexagon-head bolt – Strut	4 ea.
	Also use for all-wheel drive	
PAF911439	⇒ Cheese head bolt – Cardan shaft	4 ea.

Required materials (usually already available at the Porsche dealer):

Part No.	Designation	Qty.
00004321044	⇒ Transmission oil	20-liter/ 5.28 gallon container ¹⁾

¹⁾ approx. 6 liter/ 1.58 gallon required per vehicle.

Invoicing (17A - 17B): For documentation and warranty invoicing, enter the labor operations, PQIS coding and relevant part numbers specified below in the warranty claim:

APOS	Labour operation	I No.
37025550	Changing ATF	
37341905	Removing and installing double clutch transmission (Coupé, without ATF)	
37341907	Removing and installing double clutch transmission (Coupé, with PDCC)	
37341915	Removing and installing double clutch transmission (Targa/Cabriolet, without PDCC)	
37341917	Removing and installing double clutch transmission (Targa/Cabriolet, with PDCC)	

PQIS coding:

Location (FES5)	37370	Transmission housing
Damage type (SA4)	1511	Break

Parts Info (18): **Parts required** (for final drive breather):

Part No.	Designation - Use	Qty.
Parts required for checking oil level		
PAF009390	⇒ Screw plug with sealing ring	1 ea.
9A700852600	⇒ Screw plug with sealing ring	1 ea.
PAF008528	⇒ Screw plug with sealing ring	1 ea.
Parts required for replacing transmission		
ODT300041BX	⇒ Transmission (I-no. G1F)	1 ea.
or		
ODT300043BX	⇒ Transmission with differential lock (I-no. G1F)	1 ea.
or		
ODT300061BX	⇒ Transmission (I-no. G1G)	1 ea.
or		
ODT300063BX	⇒ Transmission with differential lock (I-no. G1G)	1 ea.
Additional parts required		
WHT008727	⇒ Cheese head bolt - Drive shaft	12 ea.
9A740735700	⇒ Plate - Drive shaft	6 ea.
PAF008673	⇒ Hexagon-head bolt - Rear axle carrier	2 ea.
PAF008735	⇒ Hexagon-head bolt - Rear axle carrier	2 ea.
WHT007957	⇒ Hexagon self-clinching nut - Connecting link	2 ea.
or		
9A700781900	⇒ Hexagon nut - Connecting link (PDCC)	2 ea.
PAF909664	⇒ Hexagon collar nut - Lower trailing arm	2 ea.
PAF008674	⇒ Hexagon flange bolt - Lower trailing arm	2 ea.
WHT008676	⇒ Hexagon-head bolt - Strut	4 ea.

Also use for all-wheel drive

PAF911439

⇒ Cheese head bolt
– Cardan shaft

4 ea.

Invoicing (18): For documentation and warranty invoicing, enter the labor operations, PQIS coding and relevant part numbers specified below in the warranty claim:

APOS	Labour operation	I No.
37341905	Removing and installing double clutch transmission (Coupé, without PDCC)	
37341907	Removing and installing double clutch transmission (Coupé, with PDCC)	
37341915	Removing and installing double clutch transmission (Targa/Cabriolet, without PDCC)	
37341917	Removing and installing double clutch transmission (Targa/Cabriolet, with PDCC)	

PQIS coding:

Location (FES5)	37370	Transmission housing
Damage type (SA4)	1511	Break

Leaks in the area (lower side of transmission)

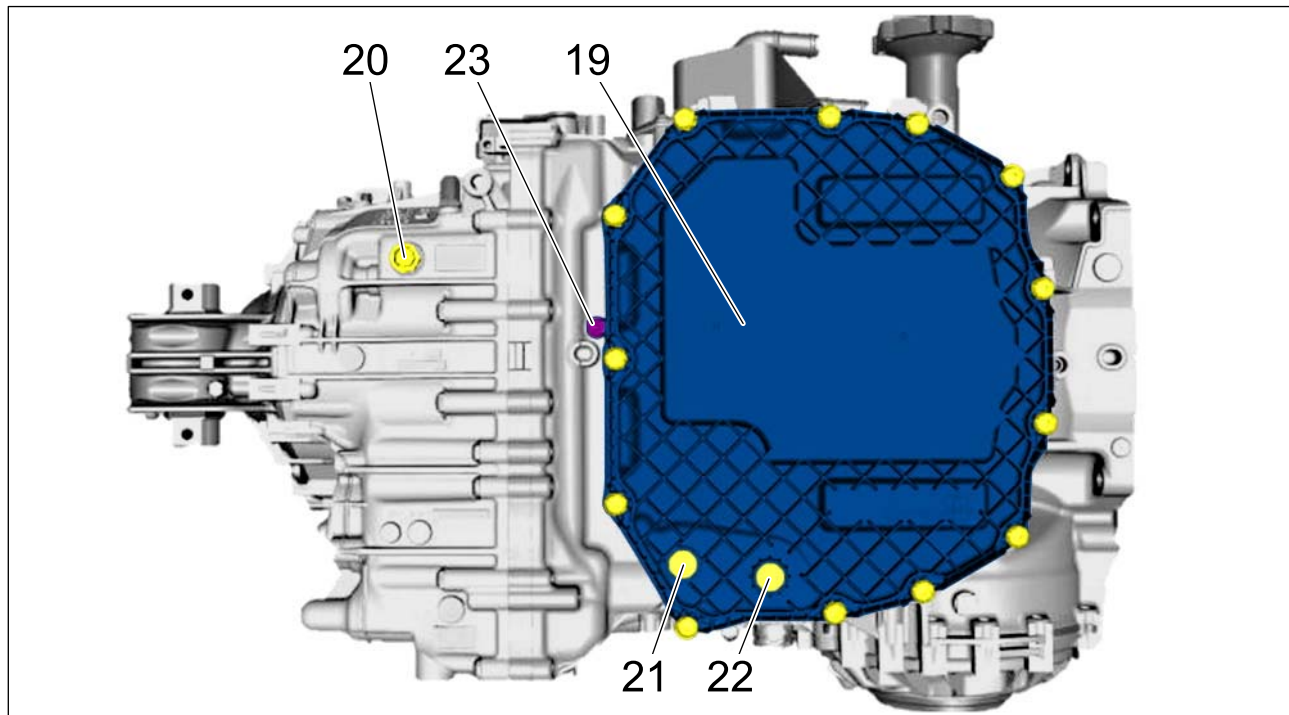

Lower side of transmission

Position	Oil leak	Cause	Repair measure
⇒ Lower side of transmission -19-	ATF pan 19A - 19C	Screw loose (A)	Replace ATF pan, see ⇒ <i>Workshop Manual '375519 Removing and installing ATF pan'</i> .
		Seal damaged (B)	
		Traces of oil after opening the hydraulic chamber (C)	Clean the ATF pan.
⇒ Lower side of transmission -20-	Screw plug 20A - 20B	Screw loose (A)	Replace screw, see ⇒ <i>Workshop Manual '399035 Checking and topping up oil for final drive (PDK gear-wheel oil)'</i> .
		Sealing ring damaged (B)	
⇒ Lower side of transmission -21-	Screw plug 21A - 21B	Screw loose (A)	Replace screw, see ⇒ <i>Workshop Manual '370235 Checking and topping up ATF'</i> .
		Sealing ring damaged (B)	

⇒ Lower side of transmission -22-	Oil drain plug 22A - 22B	Screw loose (A)	Replace screw, see ⇒ <i>Workshop Manual '370255 Changing ATF'</i> .
		Sealing ring damaged (B)	
⇒ Lower side of transmission -23-	Oil chamber partition	Shaft sealing ring damaged	Replace double clutch transmission, see ⇒ <i>Workshop Manual '373419 Removing and installing double clutch transmission'</i> .

Parts Info and Materials (19A - 19B): **Parts required** (for ATF pan):

Part No.	Designation	Qty.
ODT317165	⇒ Transmission oil pan	1 ea.
PAF009388	⇒ Internal hexagon round-head bolt	13 ea.

Required materials (usually already available at the Porsche dealer):

Part No.	Designation	Qty.
00004321044	⇒ Transmission oil	20-liter/ 5.28 gallon container ¹⁾

¹⁾ approx. 6 liter/ 1.58 gallon required per vehicle.

Invoicing (19A - 19B): For documentation and warranty invoicing, enter the labor operations, PQIS coding and relevant part numbers specified below in the warranty claim:

APOS	Labour operation	I No.
37551952	Removing and installing ATF pan	

PQIS coding:

19A - 19C

Fault location (FES5)	37550	ATF pan
Damage category (SA4)	1511	Break

Parts Info (20A - **Parts required** (for screw plug):
20B):

Part No.	Designation	Qty.
9A700852600	⇒ Screw plug with sealing ring	1 ea.

Invoicing (20A - For documentation and warranty invoicing, enter the labor operations, PQIS coding and relevant part numbers specified below in the warranty claim:
20B):

APOS	Labour operation	I No.
37374955	Reworking transmission housing	

PQIS coding:

Location (FES5)	37370	Transmission housing
Damage type (SA4)	1511	Break

Parts Info (21A - **Parts required** (for screw plug):
21B):

Part No.	Designation	Qty.
PAF009390	⇒ Screw plug with sealing ring	1 ea.

Invoicing (21A - For documentation and warranty invoicing, enter the labor operations, PQIS coding and relevant part numbers specified below in the warranty claim:
21B):

APOS	Labour operation	I No.
34571951	Removing and installing oil drain plug	

PQIS coding:

Location (FES5)	34570	Oil drain plug
Damage type (SA4)	1817	Loose

Parts Info and **Parts required** (for oil drain plug):
Materials (22A -
22B):

Part No.	Designation	Qty.
PAF009390	⇒ Screw plug with sealing ring	1 ea.
PAF008528	⇒ Screw plug with sealing ring	1 ea.

Required materials (usually already available at the Porsche dealer):

Part No.	Designation	Qty.
00004321044	⇒ Transmission oil	20-liter/ 5.28 gallon container ¹⁾

¹⁾ approx. 6 liter/ 1.58 gallon required per vehicle.

Invoicing (22A - 22B): For documentation and warranty invoicing, enter the labor operations, PQIS coding and relevant part numbers specified below in the warranty claim:

APOS	Labour operation	I No.
34571952	Removing and installing oil drain plug	

PQIS coding:

Location (FES5)	34570	Oil drain plug
Damage type (SA4)	1817	Loose

Parts Info (23): **Parts required** (for oil chamber partition):

Part No.	Designation - Use	Qty.
ODT300041BX	⇒ Transmission (I-no. G1F)	1 ea.
	or	
ODT300043BX	⇒ Transmission with differential lock (I-no. G1F)	1 ea.
	or	
ODT300061BX	⇒ Transmission (I-no. G1G)	1 ea.
	or	
ODT300063BX	⇒ Transmission with differential lock (I-no. G1G)	1 ea.
	Additional parts required	
WHT008727	⇒ Cheese head bolt - Drive shaft	12 ea.
9A740735700	⇒ Plate - Drive shaft	6 ea.
PAF008673	⇒ Hexagon-head bolt - Rear axle carrier	2 ea.
PAF008735	⇒ Hexagon-head bolt - Rear axle carrier	2 ea.

WHT007957	⇒ Hexagon self-clinching nut – Connecting link	2 ea.
or		
9A700781900	⇒ Hexagon nut – Connecting link (PDCC)	2 ea.
PAF909664	⇒ Hexagon collar nut – Lower trailing arm	2 ea.
PAF008674	⇒ Hexagon flange bolt – Lower trailing arm	2 ea.
WHT008676	⇒ Hexagon-head bolt – Strut	4 ea.
Also use for all-wheel drive		
PAF911439	⇒ Cheese head bolt – Cardan shaft	4 ea.

Invoicing (23): For documentation and warranty invoicing, enter the labor operations, PQIS coding and relevant part numbers specified below in the warranty claim:

APOS	Labour operation	I No.
37341905	Removing and installing double clutch transmission (Coupé, without PDCC)	
37341907	Removing and installing double clutch transmission (Coupé, with PDCC)	
37341915	Removing and installing double clutch transmission (Targa/Cabriolet, without PDCC)	
37341917	Removing and installing double clutch transmission (Targa/Cabriolet, with PDCC)	

PQIS coding:

Location (FES5)	37370	Transmission housing
Damage type (SA4)	1511	Break

Leaks in the area (rear side of transmission)

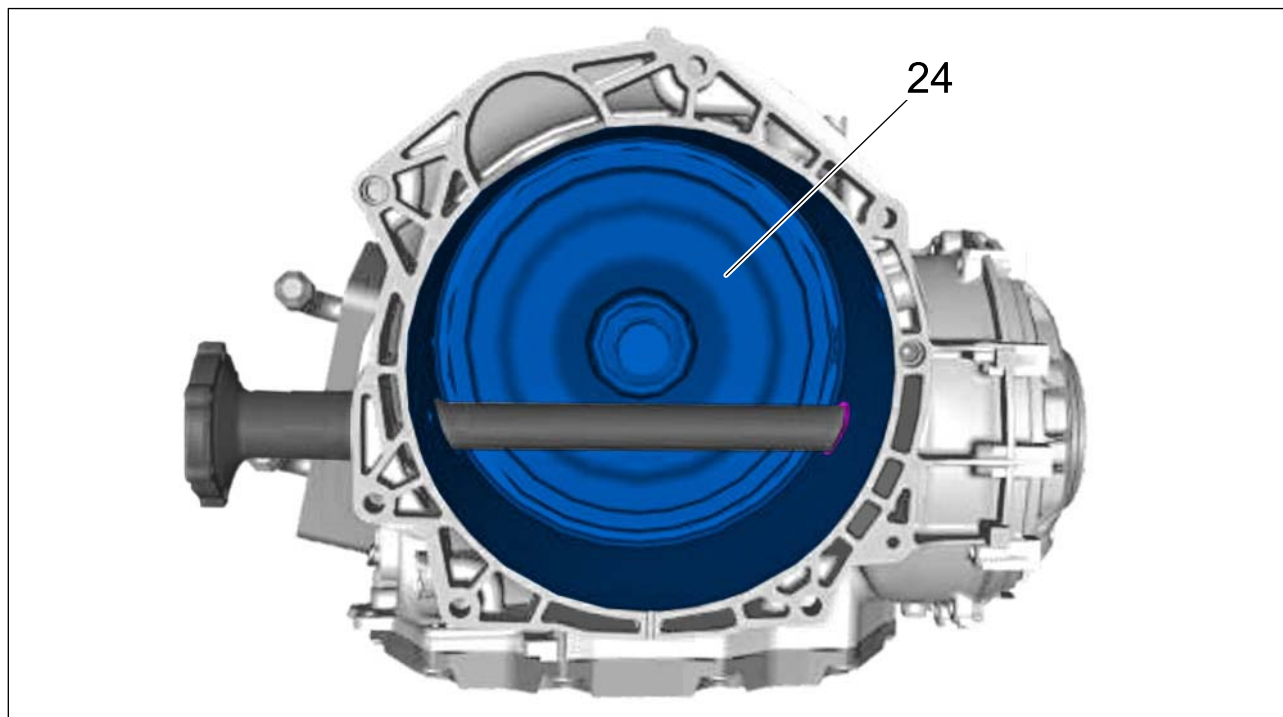

Rear side of transmission

Position	Oil leak	Cause	Repair measure
⇒ Rear side of transmission -24-	Clutch bell-housing 24A - 24E	O-ring on clutch cover damaged (A)	Replace double clutch transmission, see ⇒ <i>Workshop Manual '373419 Removing and installing double clutch transmission'</i> .
		Intermediate shaft sealing ring damaged (B)	Replace sealing ring, see ⇒ <i>Workshop Manual '386955 Replacing radial shaft seal'</i> .
		Engine leaking (C)	Find oil leaks and fix them.
		Apparent preservative grease leak (D)	No action required.
		Flanged-shaft sealing ring damaged (E)	Replace sealing ring, see ⇒ <i>Workshop Manual '391555 Replacing flanged-shaft sealing ring'</i> .

Parts Info (24A - **Parts required** (for clutch bell-housing):
24E):

Part No.	Designation - Use	Qty.
ODT300041BX	⇒ Transmission (I-no. G1F)	1 ea.
	or	
ODT300043BX	⇒ Transmission with differential lock (I-no. G1F)	1 ea.
	or	
ODT300061BX	⇒ Transmission (I-no. G1G)	1 ea.
	or	
ODT300063BX	⇒ Transmission with differential lock (I-no. G1G)	1 ea.
	or	
9A714242600	⇒ Shaft sealing ring - Intermediate shaft	1 ea.
	or	
ODT321176	⇒ Shaft sealing ring - Flanged shaft	1 ea.
	Additional parts required	
WHT008727	⇒ Cheese head bolt - Drive shaft	12 ea.
9A740735700	⇒ Plate - Drive shaft	6 ea.
PAF008673	⇒ Hexagon-head bolt - Rear axle carrier	2 ea.
PAF008735	⇒ Hexagon-head bolt - Rear axle carrier	2 ea.
WHT007957	⇒ Hexagon self-clinching nut - Connecting link	2 ea.
	or	
9A700781900	⇒ Hexagon nut - Connecting link (PDCC)	2 ea.
PAF909664	⇒ Hexagon collar nut - Lower trailing arm	2 ea.
PAF008674	⇒ Hexagon flange bolt - Lower trailing arm	2 ea.
WHT008676	⇒ Hexagon-head bolt - Strut	4 ea.

Also use for all-wheel drive

PAF911439

⇒ Cheese head bolt
 – Cardan shaft

4 ea.

Invoicing (24A - 24E): For documentation and warranty invoicing, enter the labor operations, PQIS coding and relevant part numbers specified below in the warranty claim:

APOS	Labour operation	I No.
37341905	Removing and installing double clutch transmission (Coupé, without PDCC)	
37341907	Removing and installing double clutch transmission (Coupé, with PDCC)	
37341915	Removing and installing double clutch transmission (Targa/Cabriolet, without PDCC)	
37341917	Removing and installing double clutch transmission (Targa/Cabriolet, with PDCC)	
38695552	Replacing radial shaft seal	
39155558	Replacing flanged-shaft sealing ring	

PQIS coding:

Location (FES5)	37370	Transmission housing
Damage type (SA4)	1511	Break

Leaks in the area (front side of transmission)

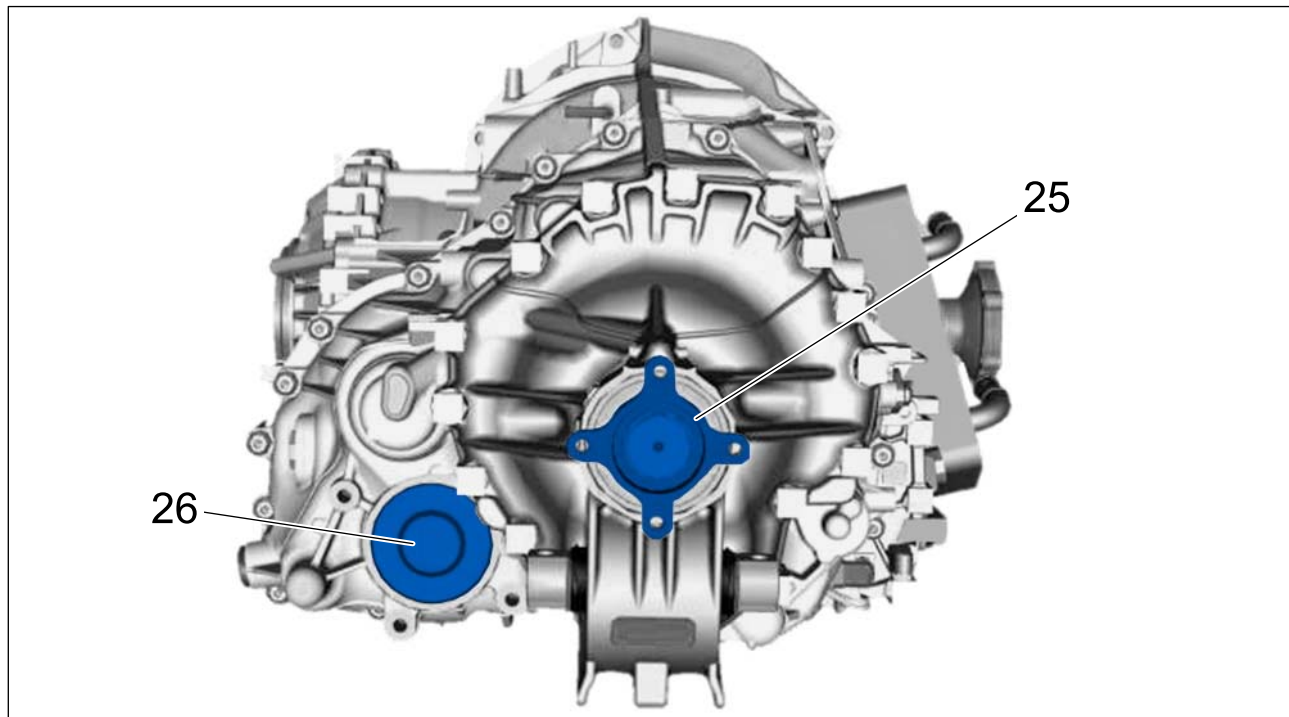

Front side of transmission

Position	Oil leak	Cause	Repair measure
⇒ Front side of transmission -25-	Output flange 25A - 25B	Sealing ring damaged (A)	Replace sealing ring and output flange, see ⇒ Workshop Manual '398255 Replacing cardan flange sealing ring'.
		Output flange leaking (B)	
⇒ Front side of transmission -26-	Cap	Cover damaged	Replace cover, see ⇒ Workshop Manual '374955 Replacing cover'.

Parts Info (25A - **Parts required** (for cardan flange):
25B):

Part No.	Designation - Use	Qty.
ODT341272	⇒ Output flange - Cardan shaft	1 ea.

ODT301733	⇒ Shaft sealing ring – Output flange	1 ea.
ODT311183	⇒ Circlip – Output flange	1 ea.
ODT301289	⇒ Dust boot – Output flange	1 ea.
WHT008727	⇒ Cheese head bolt – Drive shaft	12 ea.
9A740735700	⇒ Plate – Drive shaft	6 ea.
PAF911439	⇒ Cheese head bolt – Cardan shaft	4 ea.
PAF008673	⇒ Hexagon-head bolt – Rear axle carrier	2 ea.
PAF008735	⇒ Hexagon-head bolt – Rear axle carrier	2 ea.
WHT007957	⇒ Hexagon self-clinching nut – Connecting link	2 ea.
or		
9A700781900	⇒ Hexagon nut – Connecting link (PDCC)	2 ea.
PAF909664	⇒ Hexagon collar nut – Lower trailing arm	2 ea.
PAF008674	⇒ Hexagon flange bolt – Lower trailing arm	2 ea.
WHT008676	⇒ Hexagon-head bolt – Strut	4 ea.

Invoicing (25A - 25B): For documentation and warranty invoicing, enter the labor operations, PQIS coding and relevant part numbers specified below in the warranty claim:

APOS	Labour operation	I No.
39825552	Replacing cardan flange sealing ring	

PQIS coding:

Location (FES5)	39640	Cardan flange
Damage type (SA4)	5043	Oil leak

Parts Info (26): **Parts required** (for cover):

Part No.	Designation - Use	Qty.
ODT321073	⇒ Cover - Transmission housing	1 ea.
PAF008673	⇒ Hexagon-head bolt - Rear axle carrier	2 ea.
PAF008735	⇒ Hexagon-head bolt - Rear axle carrier	2 ea.
WHT007957	⇒ Hexagon self-clinching nut - Connecting link	2 ea.
or		
9A700781900	⇒ Hexagon nut - Connecting link (PDCC)	2 ea.
PAF909664	⇒ Hexagon collar nut - Lower trailing arm	2 ea.
PAF008674	⇒ Hexagon flange bolt - Lower trailing arm	2 ea.
Also use for all-wheel drive		
PAF911439	⇒ Cheese head bolt - Cardan shaft	4 ea.

Invoicing (26): For documentation and warranty invoicing, enter the labor operations, PQIS coding and relevant part numbers specified below in the warranty claim:

APOS	Labour operation	I No.
37495552	Replacing cover	

PQIS coding:

Location (FES5)	37490	Cover
Damage type (SA4)	1817	Loose

Concluding work

- Work Procedure: 1 Check and top up ATF, see ⇒ *Workshop Manual '370235 Checking and topping up ATF'*.
- 2 Check and top up oil for final drive, see ⇒ *Workshop Manual '399035 Checking and topping up oil for final drive (PDK gear-wheel oil)'*.
- 3 Install rear cover, see ⇒ *Workshop Manual '519419 Removing and installing rear cover'*.

Parts Info:

Part No.	Designation	Qty.
PAF009390	⇒ Screw plug with sealing ring (unless it has already been replaced)	1 ea.
9A700852600	⇒ Screw plug with sealing ring (unless it has already been replaced)	1 ea.
PAF008528	⇒ Screw plug with sealing ring (unless it has already been replaced)	1 ea.

Materials:

Required materials (usually already available at the Porsche dealer):

Part No.	Designation	Qty.
00004321044	⇒ Transmission oil (unless it has already been checked and topped up)	20-liter/ 5.28 gallon container ¹⁾

¹⁾ approx. 0.1 liter/ 3.38 fl. oz. required per vehicle.

Invoicing:

For documentation and warranty invoicing, enter the labor operations, PQIS coding and relevant part numbers specified below in the warranty claim:

APOS	Labor operation	I No.
37340100	Checking double clutch transmission	

APOS	Labor operation	I No.
37023550	Checking and topping up ATF	
39903550	Checking and topping up oil for final drive	

PQIS coding:

Location (FES5)	37340	Double clutch transmission
Damage type (SA4)	1611	Does not function

Important Notice: Technical Bulletins issued by Porsche Cars North America, Inc. are intended only for use by professional automotive technicians who have attended Porsche service training courses. They are written to inform those technicians of conditions that may occur on some Porsche vehicles, or to provide information that could assist in the proper servicing of a vehicle. Porsche special tools may be necessary in order to perform certain operations identified in these bulletins. Use of tools and procedures other than those Porsche recommends in these bulletins may be detrimental to the safe operation of your vehicle, and may endanger the people working on it. Properly trained Porsche technicians have the equipment, tools, safety instructions, and know-how to do the job properly and safely. Part numbers listed in these bulletins are for reference only. The work procedures updated electronically in the Porsche PIWIS diagnostic and testing device take precedence and, in the event of a discrepancy, the work procedures in the PIWIS Tester are the ones that must be followed.

© 2020 Porsche Cars North America, Inc.