

P4 Next Gen Cascadia dome lights stay...



[Kyle Siebert](#) 3,906 posts since Nov 14, 2014

P4 Next Gen Cascadia dome lights stay on while driving Nov 7, 2018 3:28 AM

Found if you get in, start it up, release brakes and drive the dome lights stay on.

But if you get in, start it up and wait 30 or so seconds the dome light goes out and you release the park brake and drive it the dome lights stay off.

Parameter for dome light says like 18 mph. I'll check sSam software levels tomorrow and provide a vin. Seems like a issue with sSam software.

Anyone else seen this issue?

Tags: p4, next gen cascadia, dome lamp



[Talbert Simonian](#) 1,741 posts since Nov 21, 2014

Re: P4 Next Gen Cascadia dome lights stay on while driving Nov 7, 2018 3:51 AM

No I have not look into it. I had one technician ask me about something similar about it. The driver wanted to be able to turn the dome lights on. When driving down the road. I could not find anything but the parameter it had in the SSAM. This was on the weekend. So I was not able to pursue it.



[Michael Palumbo](#) 1,371 posts since Nov 13, 2014

Re: P4 Next Gen Cascadia dome lights stay on while driving Nov 7, 2018 11:01 AM

Look at figure 3.21 in the drivers manual. I have not tried it but it looks like you can adjust courtesy lighting timer via the ICU.



[Kyle Siebert](#) 3,906 posts since Nov 14, 2014

Re: P4 Next Gen Cascadia dome lights stay on while driving Nov 7, 2018 4:07 PM

I see that on the ICU. Settings, lighting, Entrance light mode enabled and entrance light timer set for 30 seconds. Mine you get in and close the door, 30 seconds later light goes off. But if you get in and key on the light stays on till you manually push the dome light switch. Doesn't matter if you key on start and idle, key on and drive 55mph the light stays on.



[Kyle Siebert](#) 3,906 posts since Nov 14, 2014

Re: P4 Next Gen Cascadia dome lights stay on while driving Nov 7, 2018 5:04 PM

Updated SSAM and thought it took care of it. Opened door, lamp came on, closed door lamp on, key on and lamp goes out. Did this 3 times and the third time it just went back to acting up again. Acted up 4 times,

P4 Next Gen Cascadia dome lights stay...

connected diaglink to get logfile but now it wont act up. Found if I leave door open and key on lights go out anyway. Kind of at a loss now. All grounds have been checked for the 5 other issues it was brought in for. HVAC top 8 pin wasn't fully latched, water in brake pedal position sensor, low moving brake squeal, HC doser for CEL and Parksmart battery cables were not connected at main batteries. 7,000 miles on the truck.

When it would stay on you key on and the lights dim for a barely noticeable moment then come back on bright.

Wont act up with diagnostic link connected now. But with it not connected it acts up every time. Great. Ill make a tech support case I guess.



[Michael Palumbo](#) 1,371 posts since Nov 13, 2014

Re: P4 Next Gen Cascadia dome lights stay on while driving Nov 7, 2018 5:21 PM

I'm not rembering, do p4 give you an door open message in the ICU? Hard to monitor door switches if it won't act up with DL8 connected Try slamming passenger door closed?



[Kyle Siebert](#) 3,906 posts since Nov 14, 2014

Re: P4 Next Gen Cascadia dome lights stay on while driving Nov 7, 2018 6:55 PM

Passenger door open and it gives me a message on the icu for door open.



[Michael Palumbo](#) 1,371 posts since Nov 13, 2014

Re: P4 Next Gen Cascadia dome lights stay on while driving Nov 8, 2018 3:57 AM

I've looked at the p4 dome schematics G06-90127 and the sSAM pinout chart. There are a lot of variations of interior lights due the various cabs/sleeper configurations (-000 to -013) Vin would help. Hate to say it, the descriptions of the different interior lights are poor.

The best I can tell, the sSAM provides both the PWM power and gnd1 ground for the dome light just in front of the sleeper curtain. That would be x9-11 and x4-3 respectively. Is that the dome you are referring to, or are more doing it? Number 9 in the attachment.

If it is, I could picture gnd1 finding it's own ground prior to returning to the sSAM cause this.

- [f602577.pdf](#) 81.4 KB Preview



[Kyle Siebert](#) 3,906 posts since Nov 14, 2014

Re: P4 Next Gen Cascadia dome lights stay on while driving Nov 8, 2018 3:19 AM

I went to another next Gen Cascadia in the shop and it didn't have this issue at all.

P4 Next Gen Cascadia dome lights stay...

Went to a sister truck and it acted up most of the time. Was able to key on and have it act up and connected diaglink with a log file. Showing 40% dome lamp brightness when it's stuck on. So I'm thinking this is a software issue for these trucks. We'll update on what we find.

If anyone else notices this issue please provide a s/n.



[Michael Palumbo](#) 1,371 posts since Nov 13, 2014

Re: P4 Next Gen Cascadia dome lights stay on while driving Nov 8, 2018 4:24 AM

Can you adjust the dome light brightness to 100% by holding the switch? Electrical TS manual 1.11.003 Dimmable Lighting.



[Kyle Siebert](#) 3,906 posts since Nov 14, 2014

Re: P4 Next Gen Cascadia dome lights stay on while driving Nov 8, 2018 9:06 PM

Yes. And you can turn it off by depressing and releasing it quickly. It's bizzare.

Edit. Video attached 4 min long.

- [59D3D99A-FA0D-4E83-A441-CB1AE24ABF90.MOV](#) 154.1 MB



[Michael Palumbo](#) 1,371 posts since Nov 13, 2014

Re: P4 Next Gen Cascadia dome lights stay on while driving Nov 14, 2018 12:17 AM

Mechanic in the bay across from me had front map lights acting similar to your dome, today. Pulled light down and found one of the three panel screws hidden behind the light was run into the wires. Sorry, no pictures.



[Kyle Siebert](#) 3,906 posts since Nov 14, 2014

Re: P4 Next Gen Cascadia dome lights stay on while driving Nov 14, 2018 12:43 AM

I wish. All three circuits have open circuit to ground with Sam and dome disconnected. Kinda been jumping thru hoops with tech support. Understandable. I have 7.2 volts to the center pin when it's stuck on. Ground pin and other ambient temp pin are at 0 volts. Unpin other end of center pin at sSam and voltage goes away, sSam putting out 9.6 volts on that pin and removed circuit has no voltage. Unpinned two dome lamp circuits from sSam and still have issue.



[Michael Palumbo](#) 1,371 posts since Nov 13, 2014

Re: P4 Next Gen Cascadia dome lights stay on while driving Nov 14, 2018 1:14 AM

7.2v I'm guessing is 60% duty cycle (PWM) of 12v? Maybe duty PWM% can be compared to what DL8 thinks it is. I would think they should match.

P4 Next Gen Cascadia dome lights stay...

Never did catch your VIN on a unit that is doing this. Wondering if it is different dash number of G06-90127 than the ones not doing it.



[Kyle Siebert](#) 3,906 posts since Nov 14, 2014

Re: P4 Next Gen Cascadia dome lights stay on while driving Nov 14, 2018 4:16 AM

Sorry mike

S/N KN2458 and sister truck KN2459 both doing this. One has 7,000 miles and the other has 8 miles. I haven't gotten around to checking any other sister trucks. There are 4 of them that are built. Ive checked other New Next Gen Cascadias but they all operate correctly.

I was able to get the truck to act up and connect diagnostic link and shows at 40% PWM every time.

[G06-90127-010](#) for pins A ground and C dome lamp. And G06-90342-007 for the ambient light feature in pin C of the dome light connector.

So far we got 10 hours into it. We were leaning towards making a case towards engineering. But we have been directed to unpin circuits B and C individually at the dome lamp and at SSAM. Then remove circuits 504F and 504C individually at SSAM.

Item 9 is my light staying on.

9	Dome Lamp, Cab
---	--------------------------------

P4 Next Gen Cascadia dome lights stay...

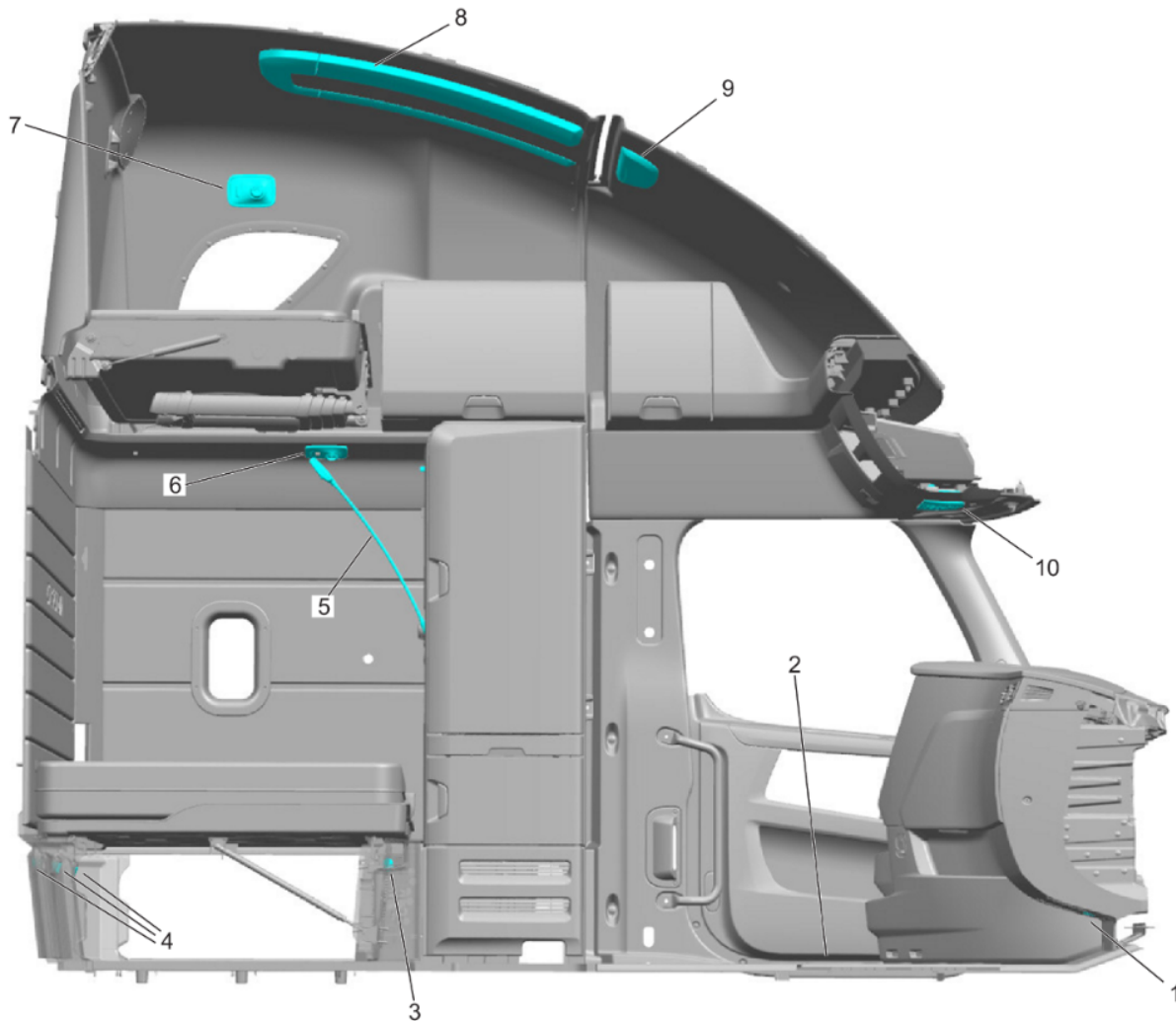

04/18/2016

f602577



[Michael Palumbo](#) 1,371 posts since Nov 13, 2014

Re: P4 Next Gen Cascadia dome lights stay on while driving Nov 14, 2018 11:54 AM

You might disconnect the radio also as the bunk speaker wires are in the same harness A66-07065-030.



[Kyle Siebert](#) 3,906 posts since Nov 14, 2014

Re: P4 Next Gen Cascadia dome lights stay on while driving Nov 15, 2018 2:39 AM

Radio disconnected still abnormal dome lamp. I'll try tomorrow to get a log file and replace the SSAM if i can't get a good log file.



[Talbert Simonian](#) 1,741 posts since Nov 21, 2014

Re: P4 Next Gen Cascadia dome lights stay on while driving Nov 16, 2018 9:44 AM

P4 Next Gen Cascadia dome lights stay...

When you do a log file. Open data stream that may allow us to look at different things that may be there.



[Michael Palumbo](#) 1,371 posts since Nov 13, 2014

Re: P4 Next Gen Cascadia dome lights stay on while driving Nov 16, 2018 11:30 AM

If your convinced it's not in the wiring then all you have left is the sSAM, sSAM parameters or the light itself.



[Kyle Siebert](#) 3,906 posts since Nov 14, 2014

Re: P4 Next Gen Cascadia dome lights stay on while driving Nov 16, 2018 12:22 PM

Could be the software too though Mike. We're going to try one last time to capture it on a log file and replace the SSAM.

[Talbert Simonian](#) "open data stream", what's that and where's that?



[Kyle Siebert](#) 3,906 posts since Nov 14, 2014

Re: P4 Next Gen Cascadia dome lights stay on while driving Nov 17, 2018 2:38 AM

Tried to just connect to SSAM only and could not duplicate issue. Put in New SSAM didn't fix it, dome lamp stayed on. Flashed new SSAM and still didn't fix it. Checked all ground pins to SSAM for voltage and X5 pin 13 had 7 volts. Found it was for MSF switch data link. Unpinned it and still lamps staying on and no voltage at removed terminal. No idea what to do now.



[Michael Palumbo](#) 1,371 posts since Nov 13, 2014

Re: P4 Next Gen Cascadia dome lights stay on while driving Nov 17, 2018 7:11 PM

Going back to your Nov 3 statement, I want to understand the following " I have 7.2 volts to the center pin when it's stuck on. Ground pin and other ambient temp pin are at 0 volts. Unpin other end of center pin at sSam and voltage goes away, sSam putting out 9.6 volts on that pin and removed circuit has no voltage."

Voltage drop from 9.6v at sSAM x9-11 to 7.2v at dome light pin b?

Also, have you tried a known good dome light from another VIN?

Looking at https://www.dtnasolutions.com/external-link.jsps?url=https%3A%2F%2Fsecure.freightliner.com%2Ffezwiring_new%2FDisplayDiagram.aspx%3FDiagramPartNo%3D%26CloseAfterDisplay%3DNo

I see more than one circuit 108d. The multiple 108d circuits don't appear to all be spliced together, so wonder if two of them are pinned backwards at the sSAM?

If you have not, remove terminal c from the dome connector, then reconnect to the dome with only terminals a&b in the connector.

P4 Next Gen Cascadia dome lights stay...



[Kyle Siebert](#) 3,906 posts since Nov 14, 2014

Re: P4 Next Gen Cascadia dome lights stay on while driving Nov 19, 2018 12:26 AM

I forget, 108C is that pin C on the lamp connector? I've had just pin c removed and it still acted up.

There is not a significant voltage drop with a 5 amp load on the pin A and B circuits. I think I remember it being a .25 volt drop. The SSAM puts out 9.6 volts with no load on the pin. I used a piece of mig wire thru the empty terminal in the connector to read this. Jumping that MIG wire to the removed terminal it reads 7.2 volts. So it appears the voltage output just changes with a loaded circuit.



[Kyle Siebert](#) 3,906 posts since Nov 14, 2014

Re: P4 Next Gen Cascadia dome lights stay on while driving Nov 20, 2018 4:50 PM

KP8918 and KP8917 is a cummins with no load disconnect switch. Doesn't have this issue.

KP1127, KP3220, KP3219, KN7080 and KL6690 are Detroit with load disconnect switch. They all have this same issue with the dome lamp.

Im thinking it has to do with the load disconnect switch somehow. Will contact DSM.



[Michael Palumbo](#) 1,371 posts since Nov 13, 2014

Re: P4 Next Gen Cascadia dome lights stay on while driving Nov 21, 2018 12:41 AM

LDS certainly is a common difference.

One other difference, you probably noticed, but I'll mention since they are interior lights is:

Cummins VINs do not have footwell lights. BOM 32b-c01845

Detroit VINs have footwell lights. BOM 32b-c01844



[Kyle Siebert](#) 3,906 posts since Nov 14, 2014

Re: P4 Next Gen Cascadia dome lights stay on while driving Nov 21, 2018 3:12 AM

I've been told that engineering won't look into it because I'm the only one to complain.

I'm going to dig up another RO. Penske complained about the dome lamp staying on with one of their new trucks. I looked at it and opened and closed the doors and couldn't duplicate the complaint. But, I never key cycled.

This seems like an innocent enough fault. Everyone that notices the dome lamp is on immediately does what? Open and closes the door and they figured the door was just not

P4 Next Gen Cascadia dome lights stay...

closed all the way. I'm sure many other trucks are effected. Now that is not normal operation.

I wouldn't want my product to have this defect. Think of the safety point. Going down the road at night isn't that noticeable when the street lamps are well lit. But suddenly your in a dark area and now you've got glare one the windshield from the dome lamp. Or you notice the dome lamp is on and your on the highway. Eh, open and close the door real quick, must have left the door ajar. Is that considered dangerous to open and close the door on the highway. It's minor dangerous but it's happening a lot more now with this issue.

So engineering is saying this isn't a valid complaint or operator error or not understanding how to use the system.

Can anyone help me out? Has anyone ever recalled this complaint? Do you have a p4 Cascadia in your shop or the next one you get into could you see if the dome lamp stays on after you close the door and key on. Should go out right at key on, so it won't take more than 10 seconds to see it.



[Russell Thornley](#) 13 posts since Nov 20, 2018

Re: P4 Next Gen Cascadia dome lights stay on while driving Jun 26, 2020 8:56 PM

We have been getting more new '20 P4 dome lamp complaints, most complaints are intermit. "dome lamps come on while driving down the road". Been unable do duplicate or confirm in shop, all are the newest P4 models, two in shop now have mileages at 19k and 29k for miles. Another dome lamp complaint resolved with just un-plugging and reinstalling it so were unsure if was fixed. No complaints from operators about "door open" notifications or dash beeps while this occurs since brakes are released, I would seem to think would be multiple complaints at the same time as dome lamps if there was door issues. We have flashed each one after exhausting searching for problems, have not had a lot of feedback if resolving though. Hope more info comes out.



[Kyle Boddy](#) 25 posts since Jan 4, 2016

Re: P4 Next Gen Cascadia dome lights stay on while driving Nov 21, 2018 10:24 AM

I am just stabbing in the dark here, but have you tried with the seat belt buckled? Is it just another warning to buckle the seat belt?

Just spit balling, but if you have been able to duplicate the complaint, try that and see if anything changes.

I too have had some customers complaint about it, not enough to have it written up on a ticket, but they have mentioned it in passing while other work is being completed.



[Justin Johnson](#) 975 posts since May 12, 2017

Re: P4 Next Gen Cascadia dome lights stay on while driving Dec 12, 2018 5:02 PM

What did you end up deciding on this one, Kyle?

P4 Next Gen Cascadia dome lights stay...



[Kyle Siebert](#) 3,906 posts since Nov 14, 2014

Re: P4 Next Gen Cascadia dome lights stay on while driving Dec 12, 2018 11:30 PM

In Portland [Joe Youngblutt](#) said they found several other trucks with the same issue and are bringing it to engineering's attention.



[Kyle Siebert](#) 3,906 posts since Nov 14, 2014

Re: P4 Next Gen Cascadia dome lights stay on while driving Dec 26, 2018 9:01 PM

S/N KK9775 is a single axle day cab without a load disconnect switch but with a Detroit. The dome lamp stays on it just like the other trucks.



[Michael Palumbo](#) 1,371 posts since Nov 13, 2014

Re: P4 Next Gen Cascadia dome lights stay on while driving Sep 1, 2020 3:15 AM

Day cab MK9841 in PDI.

DL I/O- Interior lights shows park brake interlock going from set to Traingle/exclamation sSAM 02t when dome switches back on. Does not do that every cycle of the light but did do it several time, it did seem to sync with the dome coming on. Chart shows ssam park and ssam drag disappear from log then come back, this also syncs with I/O park interlock.. I can measure the voltage drop off and pick back up at the sSAM x9/11 which is the PWM output to the effected dome.

Found and fixed damaged overhead harness and Floor harness GNDI. Neither fixed the dome issue.

VRDU fault for camera active all the time. EOS, back at it tomorrow.

Video shows what the dome is doing. It cycles like that as long as the CLDS is on. Key position, engine on or off makes no difference.

edit: attached log file and pictures of damaged wires.

- [\(3AKJHLDV0MSMK9841\) 8-31-2020 1427.38.DrumrollLog](#) 2.3 MB
- [20200831_101201.mp4](#) 34.4 MB
- [20200831_085146.jpg](#) 275.6 KB
- [20200831_123859.jpg](#) 656.9 KB