

FLA COE
 FLB COE
 FLD Conventional
 Business Class
 FLC 112 Conventional

Century Class Conventional
 Argosy
 Cargo
 Columbia
 122SD and Coronado

Business Class M2
 Cascadia
 108SD/114SD
 > New Cascadia

General Information

The multipurpose camera 2 (MPC2) power is supplied via fuse 14 (F14) in New Cascadia vehicles built before August 24, 2020. With this configuration, fault code 232/524127/9 - "Lost Communication to MPC" becomes active during low voltage disconnect (LVD) situations when load shedding is required to maintain critical systems.

These instructions provide the procedure for moving the MPC2 power supply from fuse 14 (F14) to fuse 35 (F35). Moving the MPC2 power supply requires the installation of a new etched vehicle power distribution module (VPDM) cover to document the new MPC2 location.

In vehicles built after August 24, 2020, the MPC2 is supplied by constant battery power from Fuse 35 and this etched cover is already installed.

Parts

Parts Table	
Part Number	Description
66-22194-000	VPDM Cover

Table 1, Parts Table

Work Instructions

1. Park the vehicle on a level surface, shut down the engine, and set the parking brake. Chock the tires.
2. Disconnect the batteries.
3. Remove the electrical bay cover by pulling the corner of the lower left panel loose. See [Fig. 1](#). Pull the remaining clips loose from the dash and remove the cover.

For instructions, see **Section 60.06, Subject 100** in the *New Cascadia Workshop Manual*.

4. Remove the seven screws that attach the right-hand lower dash cover to the dash and electrical bay housing, then pull the clips loose and remove the cover. See [Fig. 2](#).

Freightliner Service Bulletin

FLA COE
FLB COE
FLD Conventional
Business Class
FLC 112 Conventional

Century Class Conventional
Argosy
Cargo
Columbia
122SD and Coronado

Business Class M2
Cascadia
108SD/114SD
> New Cascadia



Fig. 1, Electrical Bay Cover Handhold

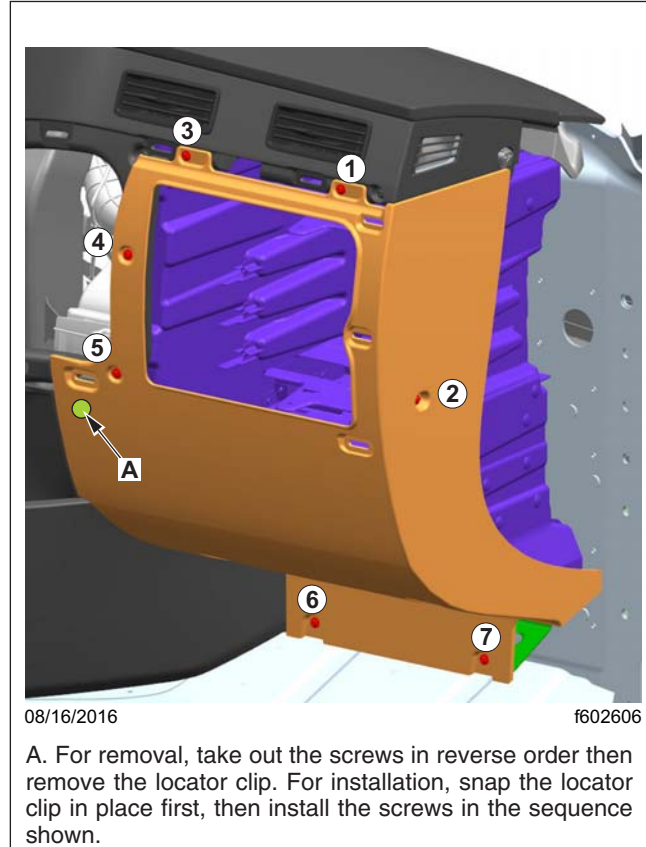

08/16/2016

f602606

A. For removal, take out the screws in reverse order then remove the locator clip. For installation, snap the locator clip in place first, then install the screws in the sequence shown.

Fig. 2, RH Lower Dash Cover

5. Remove the current VPDM cover and dispose of it.
6. Loosen the VPDM mounting screws from the outer corners of the front of the VPDM, and release the VPDM from the mounting hooks.

NOTICE

Make sure that the cab floor is clear of debris and tools. If the VPDM is lowered onto debris, especially metal objects, it could permanently damage the VPDM.

7. Gently lower the VPDM to the cab floor and remove the back cover. For instructions, see **Section 54.08, Subject 100** in the *New Cascadia Workshop Manual*.
8. Locate and remove the VPDM J5 connector. First loosen the captured screw at the front of the VPDM (see **Fig. 3**), then remove the J5 connector from the back of the VPDM. See **Fig. 4**.

Rewiring the MPC2 Camera Fuse

54-336

FLA COE
FLB COE
FLD Conventional
Business Class
FLC 112 Conventional

Century Class Conventional
Argosy
Cargo
Columbia
122SD and Coronado

Business Class M2
Cascadia
108SD/114SD
> New Cascadia

Freightliner Service Bulletin

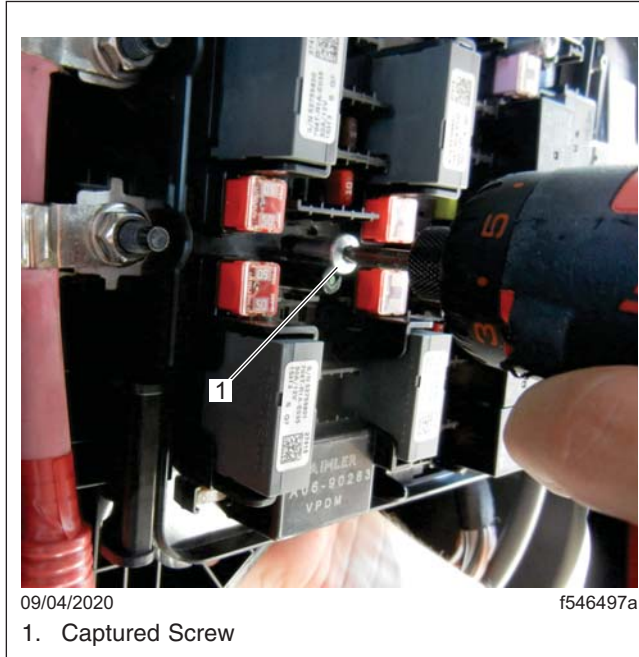

Fig. 3, Captured Screw, Front of VPDM

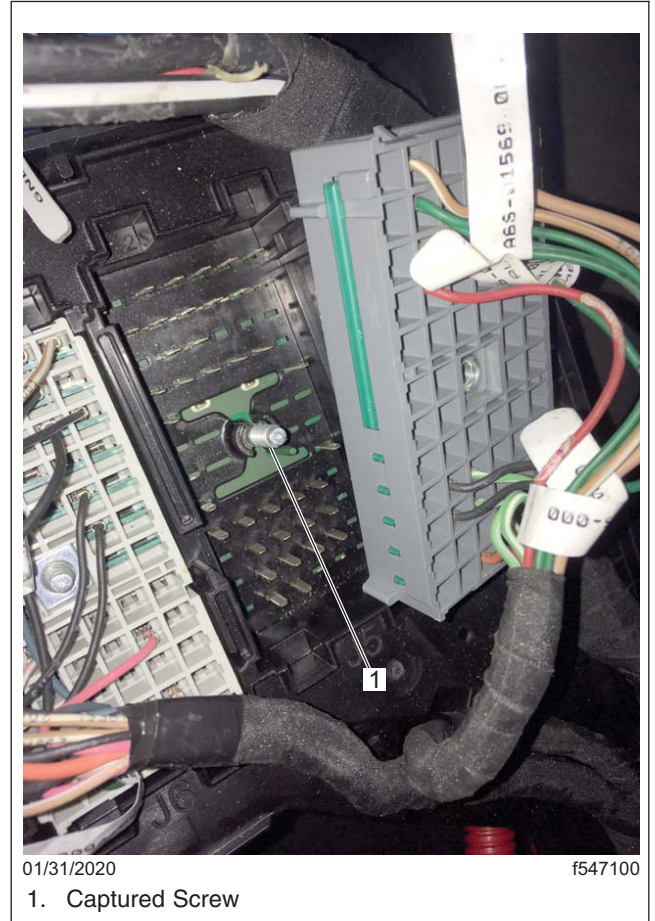

Fig. 4, J5 Connector Removed from Back of VPDM

9. Remove the green terminal locks from the J5 connector. See [Fig. 5](#).

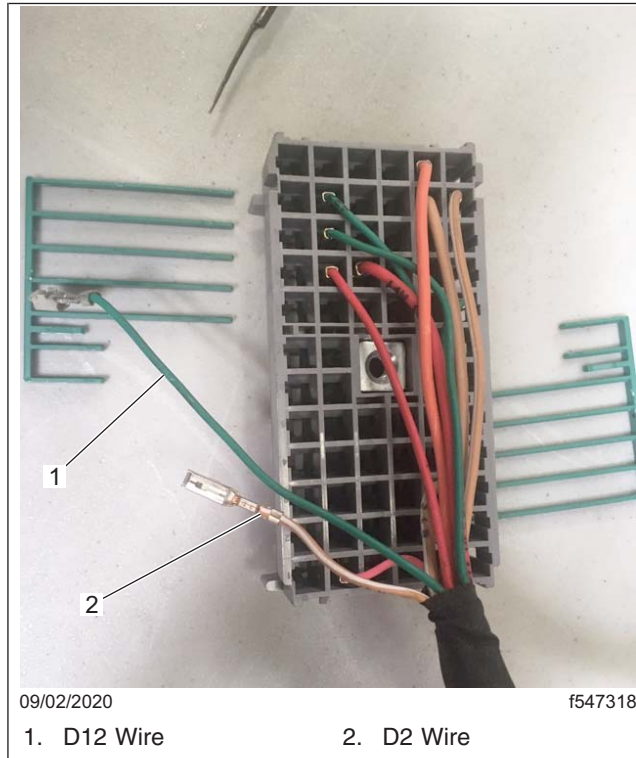

Fig. 5, Terminal Locks Removed from the J5 Connector

10. Locate both cavity D2 and cavity D12 in the J5 connector.
11. Lift up the internal D2 locking mechanism and remove the D2 pin.
12. Cut the D2 terminal off, leaving about 1 inch (25 mm) of wire extending from the terminal.
13. Strip the wire without the D2 pin 3/8 inch (10 mm).
14. If cavity D12 has a wire installed, go to step 15. If cavity D12 is empty, do the following.
 - 14.1 Cut a 4 inch (10 cm) length of wire of equal size to the D2 wire. Strip one end 3/8 inch (10 mm), and splice it onto the wire removed from cavity D2 using the appropriate sized Phillips STA-DRY® Crimp and Solder connector. Using a heat gun, carefully apply heat to melt the solder and shrink the connector tube.
 - 14.2 Strip the other end of the 4 inch wire 3/8 inch (10 mm) and strip the 1 inch (25 mm) terminal wire; splice the 4 inch wire onto the terminal end removed from D2 using the appropriate sized Phillips STA-DRY® Crimp and Solder connector. Using a heat gun, carefully apply heat to melt the solder and shrink the connector tube. Insert the terminal into cavity D12.
15. If cavity D12 in the J5 connector has a wire installed, do the following.
 - 15.1 Lift up the internal D12 locking mechanism and remove the D12 pin.
 - 15.2 Cut the D12 terminal off, cutting the wire to be an even length with the wire removed from the D2 cavity. See [Fig. 6](#).
 - 15.3 Strip the D12 wire 3/8 inch (10 mm).

FLA COE
 FLB COE
 FLD Conventional
 Business Class
 FLC 112 Conventional

Century Class Conventional
 Argosy
 Cargo
 Columbia
 122SD and Coronado

Business Class M2
 Cascadia
 108SD/114SD
 > New Cascadia

**Freightliner
 Service Bulletin**

15.4 Twist the stripped ends of the D2 and D12 wires together. Install an appropriate size Phillips STA-DRY Crimp and Solder connector. See [Fig. 7](#).

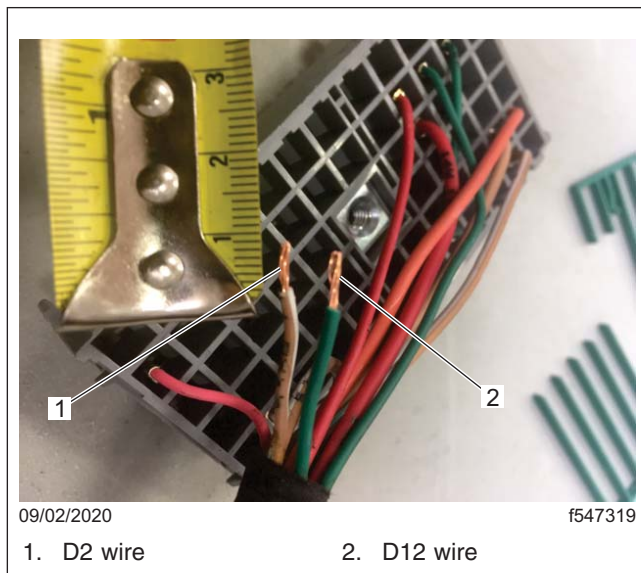

Fig. 6, Stripped D2 and D12 Wires of Equal Length

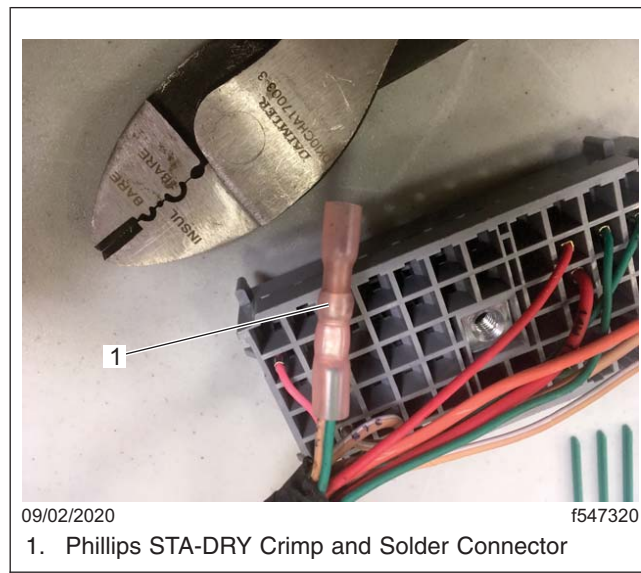

Fig. 7, D2 and D12 Wires in Connector

15.5 Using the terminal and wire removed from cavity D12, strip the end 3/4 inch (19mm) and fold the stripped wire in half. Insert the wire into the properly sized Phillips STA-DRY Crimp and Solder connector, splicing it to the twisted D2 and D12 wires. Crimp and carefully apply heat with a heat gun to melt the solder and shrink the connector tube. See [Fig. 8](#).

15.6 Insert the terminal into cavity D12. See [Fig. 9](#).

Freightliner Service Bulletin

FLA COE
FLB COE
FLD Conventional
Business Class
FLC 112 Conventional

Century Class Conventional
Argosy
Cargo
Columbia
122SD and Coronado

Business Class M2
Cascadia
108SD/114SD
> New Cascadia

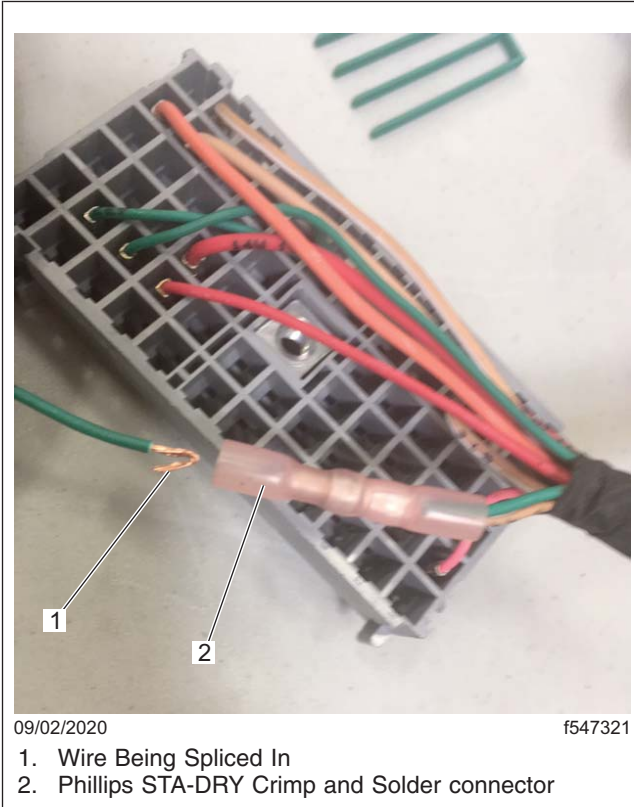

Fig. 8, Splicing Wire onto D2 and D12

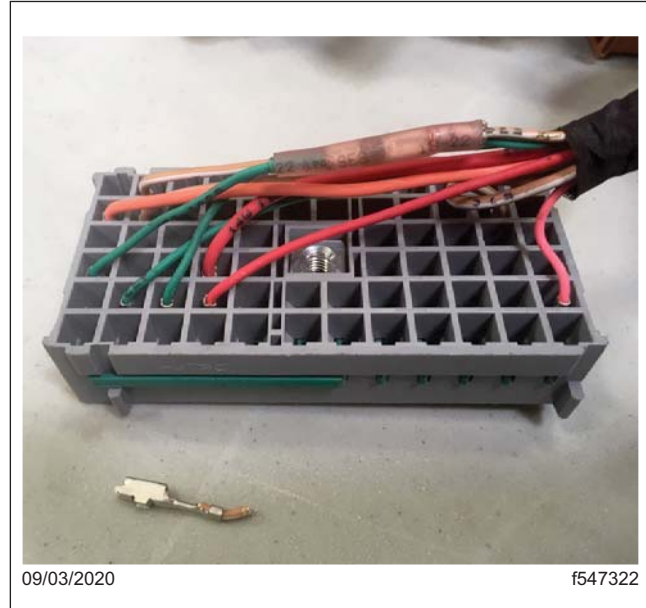

Fig. 9, Completed Splice

16. Install the green terminal locks in the J5 connector. See [Fig. 5](#).
17. Install the J5 connector onto the VPDM. Tighten the captured screw on the front of the VPDM. The screw has a green tab next to it, that extends when the screw is completely tightened. See [Fig. 10](#).

FLA COE
 FLB COE
 FLD Conventional
 Business Class
 FLC 112 Conventional

Century Class Conventional
 Argosy
 Cargo
 Columbia
 122SD and Coronado

Business Class M2
 Cascadia
 108SD/114SD
 > New Cascadia

**Freightliner
 Service Bulletin**

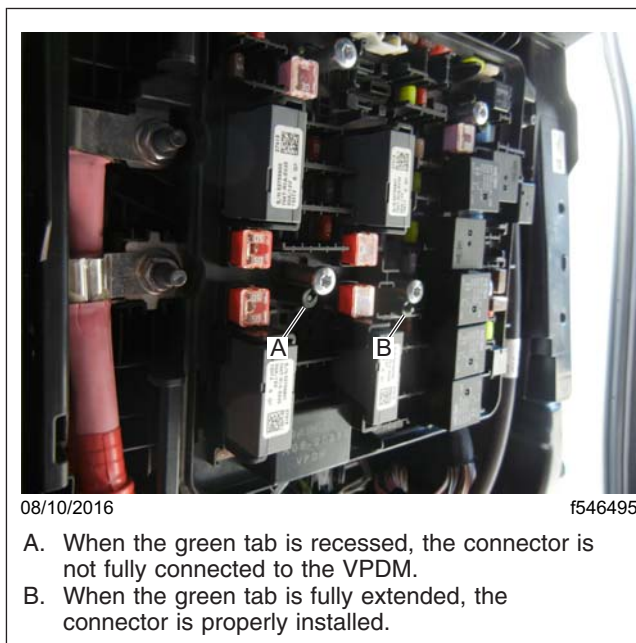

Fig. 10, Tightening the Captured Screws

18. Install the back cover on the VPDM.
19. Install the VPDM in the dash and tighten the four VPDM screws.
20. Install the new VPDM cover.
21. Install the lower dash cover by snapping the locator tab in place and then the seven screws. See [Fig. 2](#).
22. Install the electrical bay cover.
23. Connect the batteries.

Warranty

This procedure is warrantable only if the described condition exists and the repair is performed within the applicable base or extended coverage warranty period. If a failure is not found, this procedure is considered preventive and warranty does not apply.

Normal warranty applies. See [Table 2](#) for OWL VMRS codes and labor allowance information. Enter this service bulletin number in the *Service Bulletin #* field.

OWL VMRS Codes and Labor Allowance					
Primary Failed Part	Component Code	Cause Code	SRT Code	Description	Time: Hours
Dash Harness	034-004-356	19	285-5031A	MPC2 CAMERA FUSE MODIFICATION,REWIRE TO FUSE F35,PER INSRUCTIONS, (SB54-336)	0.5

Table 2, OWL VMRS Codes and Labor Allowance