

2021 GX460 Pre-Delivery Service (PDS)

Service Category General

Section Pre-Delivery Service

Market USA

Toyota Supports
ASE Certification 

Applicability

YEAR(S)	MODEL(S)	ADDITIONAL INFORMATION
2021	GX460	

Introduction

This bulletin contains the vehicle specific pre-delivery services for 2021 model year GX 460 vehicles. Additionally, refer to the applicable Pre-Delivery Service (PDS) Check Sheet for services to be performed.

Warranty Information

OP CODE	DESCRIPTION	TIME	OFF	T1	T2
N/A	Not Applicable to Warranty	–	–	–	–

Procedures

- [Short Pin Installation](#) 2
- [Memorize Steering Angle Neutral Point](#) 3
- [Tire Pressure Warning System \(TPWS\) Activation](#) 4
- [Front License Plate and Mounting Bracket Installation*](#) 6

2021 GX460 Pre-Delivery Service (PDS)

Short Pin Installation

To minimize battery discharge during transportation and storage, the short pin has been removed at the assembly plant and temporarily stored in the blank space of the relay block in the engine compartment. Reinstall the short pin into its original location and confirm ALL related Diagnostic Trouble Codes (DTCs) are cleared during PDS.

Remove the short pin from the blank space of the relay block in the engine compartment and install the short pin in the relay block as shown.

Figure 1.

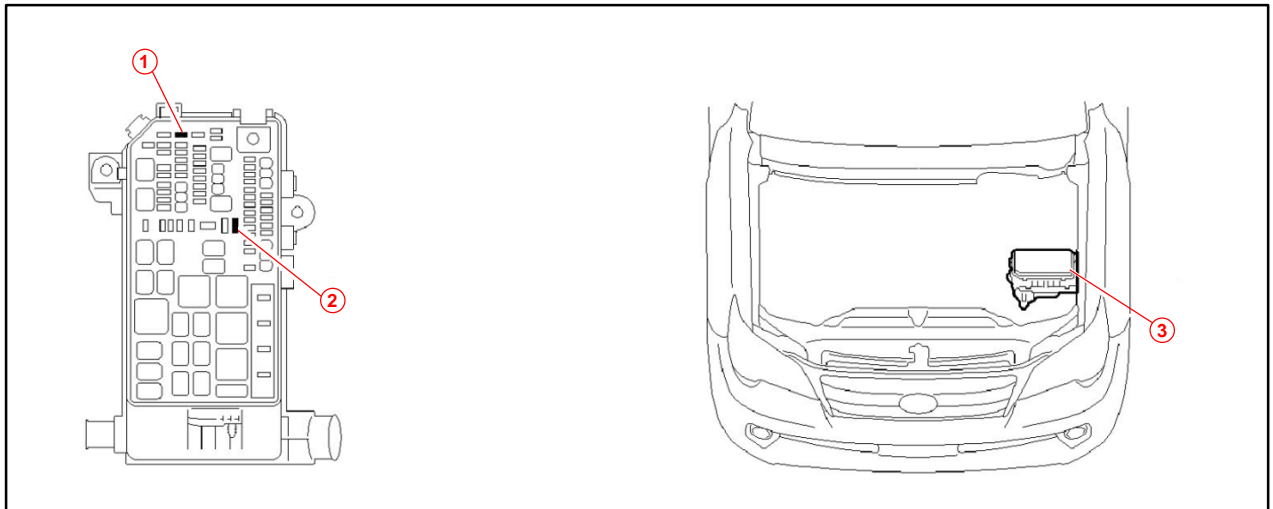

1	Remove Short Pin
2	Install Short Pin

3	Relay Block
----------	--------------------

NOTE

- The short pin does NOT function as a fuse, so install it ONLY in the position shown.
- If the vehicle is stored after PDS, disconnect the negative (-) battery terminal to prevent battery discharge. Refer to Service Bulletin No. [L-SB-0017-20](#), *Battery Maintenance During PDS*.

2021 GX460 Pre-Delivery Service (PDS)

Short Pin Installation (continued)

DTC Clearing Procedure

With the short pin removed, the occupant classification ECU and center airbag sensor assembly (airbag ECU) may detect the interruption in battery voltage (B+) and store a DTC. Clear DTCs B1650 and B1794 AFTER installing the short pin.

1. Connect Techstream to the DLC3.
2. Cycle the ignition switch to the IG-ON position.
3. Using Techstream, check for ANY DTCs.

NOTE

If ANY DTCs other than B1650 and B1794 are found, repair the applicable system according to the Repair Manual BEFORE proceeding.

4. Erase DTCs (B1650 and B1794) and Freeze Frame Data.

Memorize Steering Angle Neutral Point

As a result of the removal of the short pin, the power source to the steering angle sensor is cut off. When the short pin is reinstalled, the rear-view monitor system will be operative, but it cannot display the guidelines to assist parking operation because the center position recognized by the steering angle sensor may not be in an initial position. Therefore, perform steering angle neutral point initialization AFTER installing the short pin during PDS.

Refer to the applicable Repair Manual for the steering angle neutral point [initialization procedure](#).

2021 GX460 Pre-Delivery Service (PDS)

Tire Pressure Warning System Activation

1. AFTER cycling the ignition to the IG-ON position, the Low Tire Pressure Warning Light will blink for one minute and remain illuminated, until ALL the tire pressure warning valves/sensors are activated.
2. The DTCs listed below may be stored in the TPWS ECU until the tire pressure warning valves/sensors are activated.
3. The DTCs will automatically clear when the tire pressure warning valves/sensors are activated.

Figure 2.

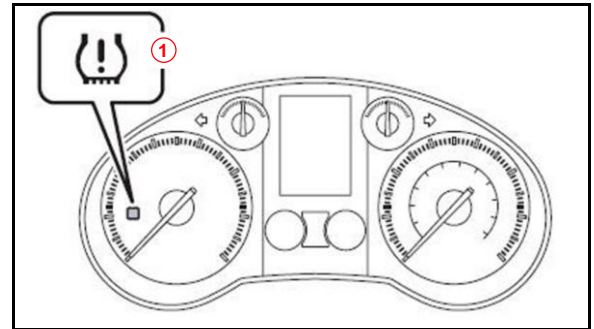

1	Low Tire Pressure Warning Light
----------	--

DTC NO. *	DTC NO. **	DTC EXPLANATION
11	C2111	Transmitter ID1 Operation Stop
12	C2112	Transmitter ID2 Operation Stop
13	C2113	Transmitter ID3 Operation Stop
14	C2114	Transmitter ID4 Operation Stop
15	C2115	Transmitter ID5 Operation Stop

*DTC No. indicated by blinking of the Low Tire Pressure Warning Light.

**DTC No. indicated on Techstream.

2021 GX460 Pre-Delivery Service (PDS)

Tire Pressure Warning System Activation (continued)

4. Connect to Techstream.
5. Cycle the ignition switch to the IG-ON position and check that the Low Tire Pressure Warning Light blinks for 1 minute and remains illuminated.
6. Press or remove the valve core to reduce the tire inflation pressure rapidly by 6 psi (0.4 kgf/cm², 40 kPa), or more within 30 seconds.
7. If the tire inflation pressure is NOT reduced by 6 psi (0.4 kgf/cm², 40 kPa), or more within 30 seconds, the tire pressure warning valves/sensors will NOT activate.

NOTE

This operation is required for the system to activate and MUST be performed for each tire (including the spare tire), one at a time.

Figure 3.

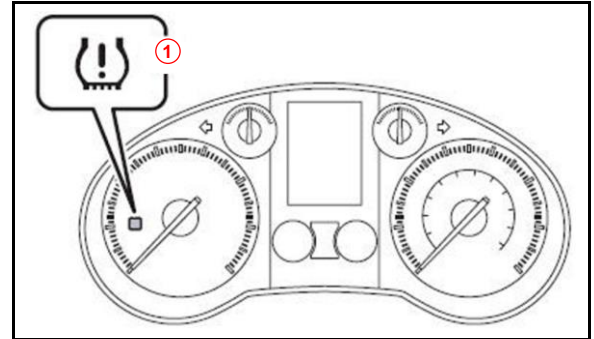

1 Low Tire Pressure Warning Light

Figure 4.

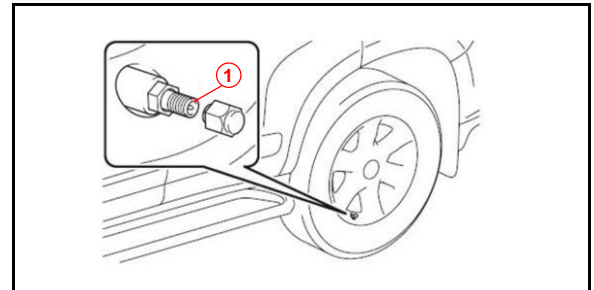

1 Core

8. Using Techstream, check for TPWS-related DTCs.
 - If NO DTCs are stored, continue to step 9.
 - If DTCs C2111 – C2115 are stored, repeat step 7.
9. Adjust ALL tires (including the spare tire) to the standard tire inflation pressure as indicated on the Tire and Loading Information label on the vehicle. Confirm the Low Tire Pressure Warning Light is OFF.

NOTE

- To adjust tire pressure correctly when outside temperature is significantly colder than shop temperature, perform a Health Check using Techstream and select the Compensation Tire Pressure checkbox. Compensation pressures will display on the Health Check results screen.
- Adjust the tire pressure when the tires are cold.

2021 GX460 Pre-Delivery Service (PDS)

Front License Plate and Mounting Bracket Installation

The front license plate mounting bracket and two self-tapping screws for the 2021 model year GX 460 are stored in the rear cargo area of the vehicle. Follow this procedure to install the front license plate bracket and front license plate in states where it is required by law.

1. Align holes "A" of the mounting bracket with the dimples on the front bumper cover. Mark the location of holes "B" on the front bumper cover.

NOTE

- Holes "A" are used to install the mounting bracket onto the bumper cover.
- Holes "B" are used to install the front license plate onto the mounting bracket.

2. Install the mounting bracket to the front bumper cover (holes "A") using the two supplied self-tapping screws.

NOTICE

- Do NOT pre-drill holes into the dimples on the front bumper cover.
- Do NOT overtighten the self-tapping screws.

Figure 5.

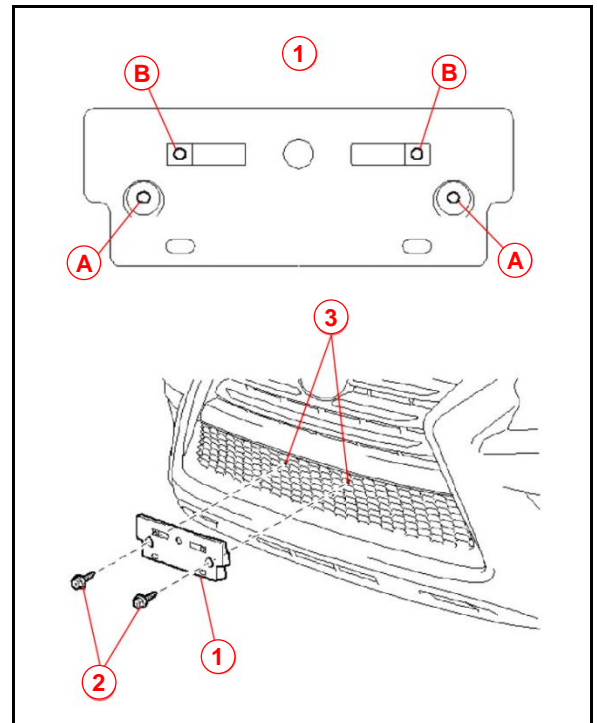

1	Mounting Bracket
2	Self-tapping Screw
3	Dimple

2021 GX460 Pre-Delivery Service (PDS)

Front License Plate and Mounting Bracket Installation (continued)

3. Install the front license plate onto the mounting bracket using two noncorroding bolts with the following dimensions.

Nominal Length: 15.0 mm (0.59 in.)

Diameter: 6.0 mm (0.24 in.)

Figure 6.

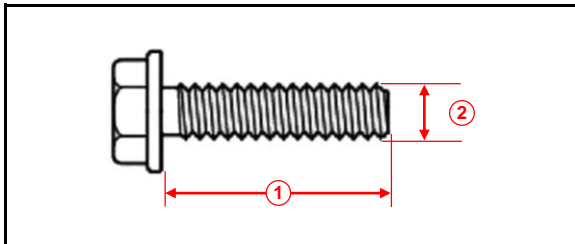

1	Nominal Length
2	Diameter

Figure 7.

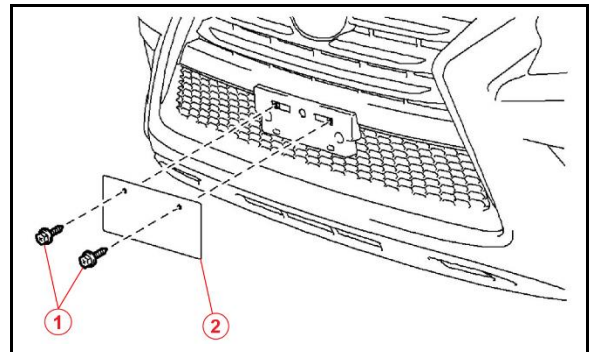

1	Bolt
2	Front License Plate