



Bulletin No.: PIT5768

Published date: N/A

Preliminary Information

PIT5768 Liftgate / Liftglass Rattle Noise and/or Liftgate Will Not Close/Latch Without Assistance

Models

Brand:	Model:	Model Years:	VIN:		Engine:	Transmissions:
			from	to		
Chevrolet	Tahoe	2021	All	All	All	All
Chevrolet	Suburban	2021	All	All	All	All
GMC	Yukon Models	2021	All	All	All	All

Involved Region or Country	North America
Condition	Some customers many comment on a rattle noise from the rear of the vehicle.
Cause	The noise could be from the liftgate and/or liftglass.

Correction:

To correct this concern perform the following repairs:

1. Open the liftglass and inspect the C-clips on the hinge pins. The C-clip should be in the outboard slot (1) for the driver's side hinge and the inboard slot (2) for the passenger side hinge, shown below. If a C-clip is not in the correct slot then remove it and reinstall it in the correct slot.

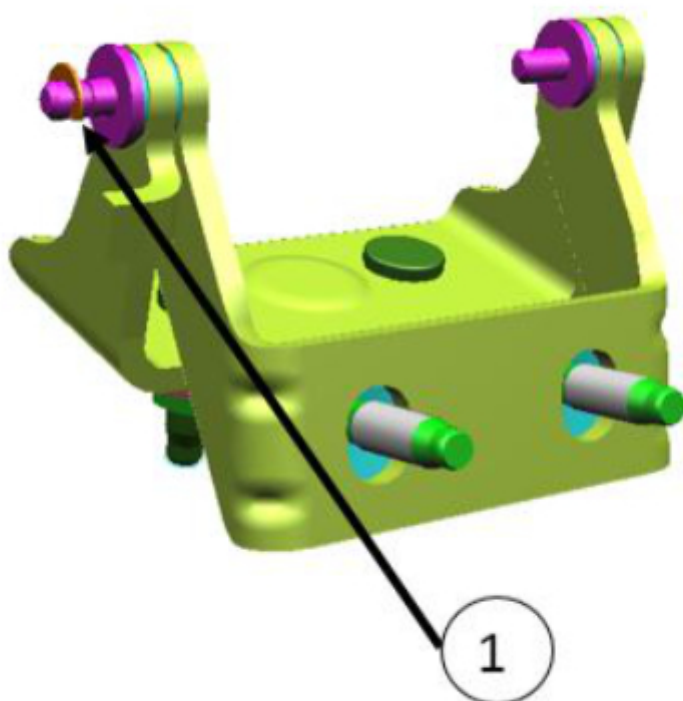

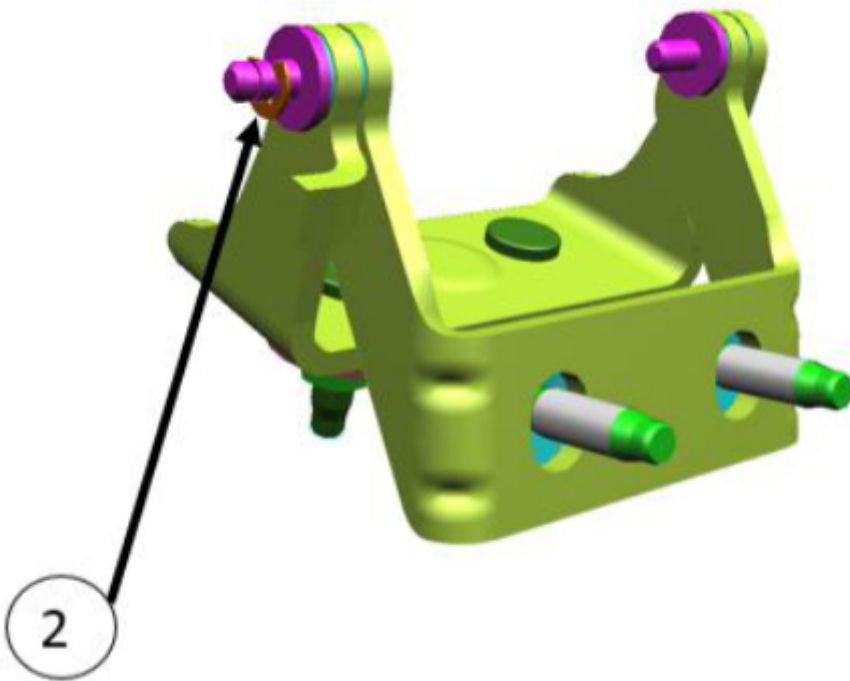

2. Inspect the rear window defroster tab covers (3) for being loose and rattling. If the cover's are loose then re-snap them into position.

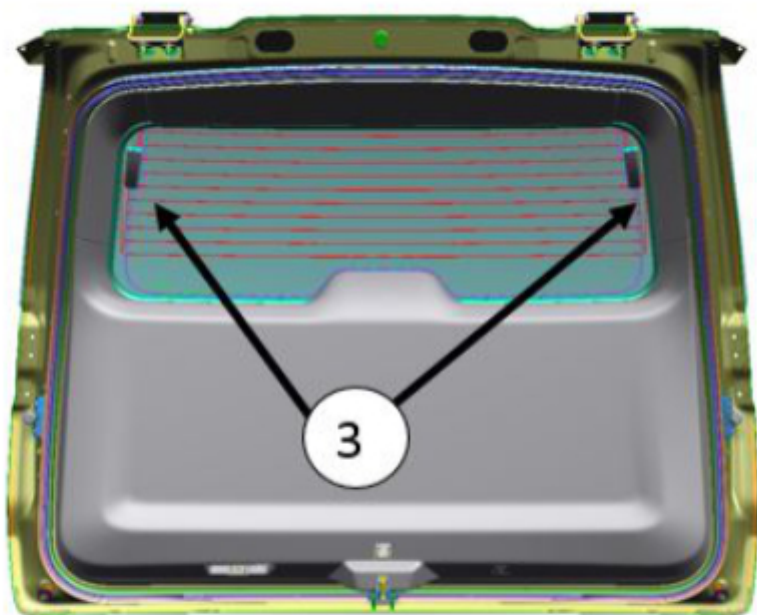

3. With the liftglass open, inspect to ensure that all fasteners that attach the spoiler to the liftglass are torqued properly. See doc ID 5601125 for all the spoiler's fastener torque specs.

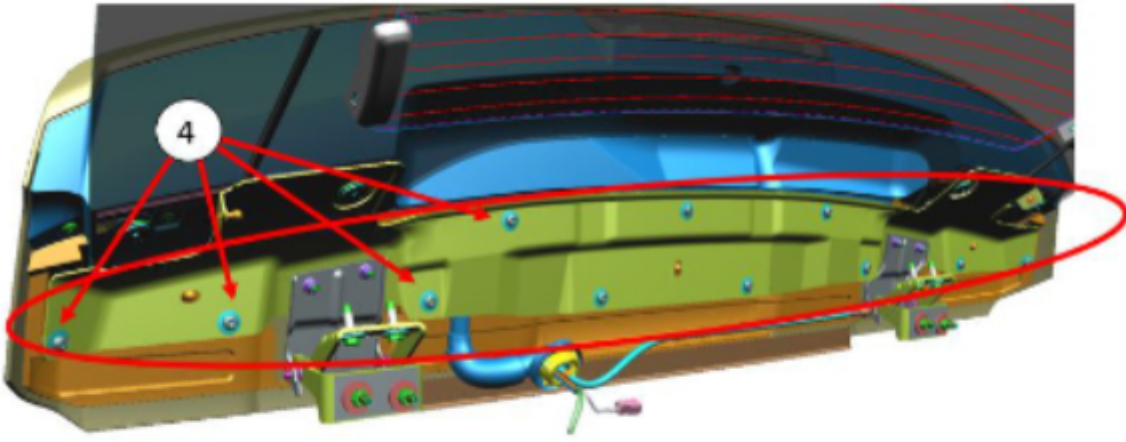

4. Using a small brush, apply GM Super Lube, GM P/N 12371287 to the liftglass latch opening (5).

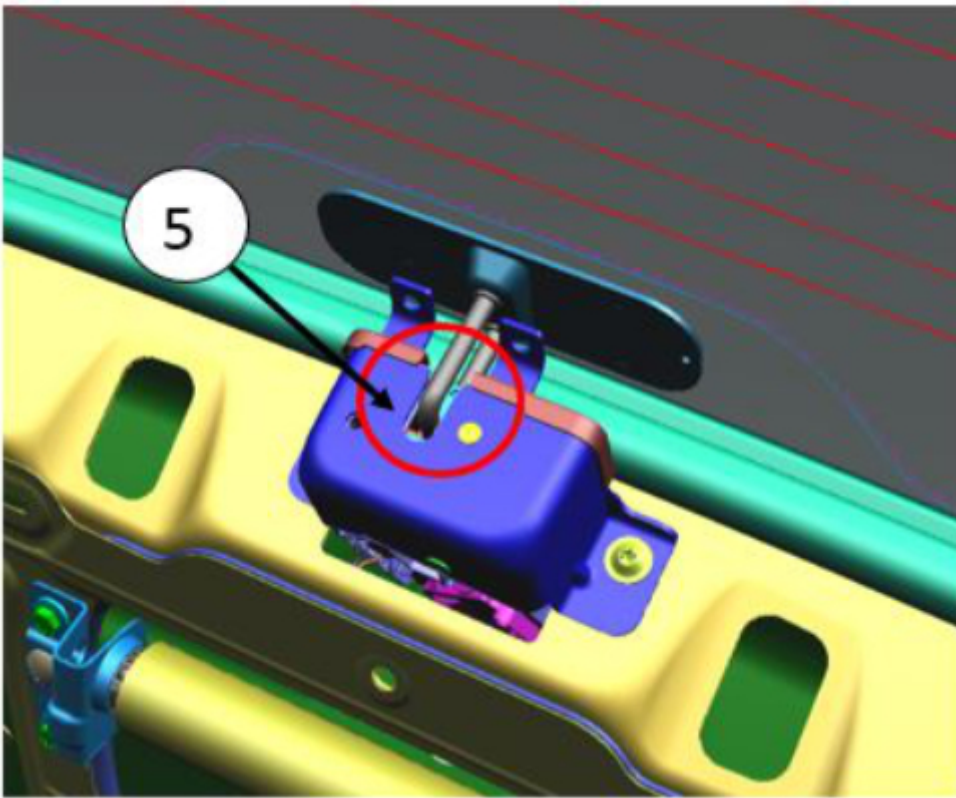

5. Inspect to make sure the liftglass seal (6) is properly seated onto the liftgate flange. See Document ID 5580159 for more info.

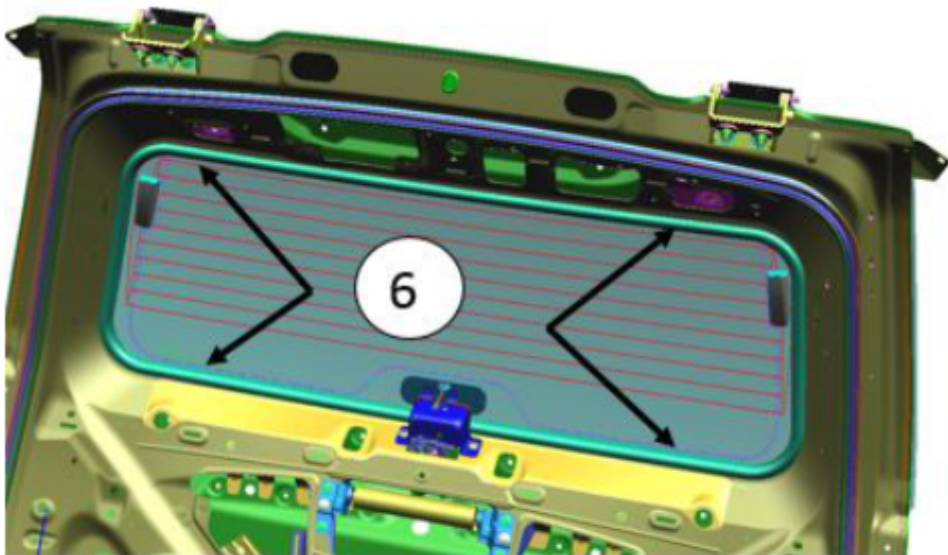

6. With the liftgate closed, push on the liftgate near the bottom as shown (7) to see if it feels soft/loose. If the liftgate has for/aft movement then adjust the liftgate striker forward 1.0mm using the steps below:



- Remove the liftgate striker trim cover (8) from sill plate.

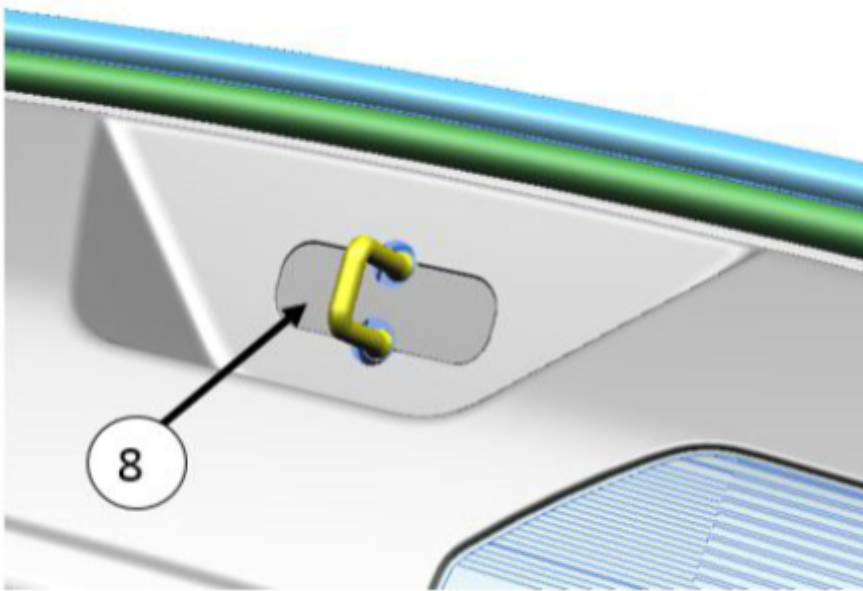

- Loosen and adjust the liftgate striker forward (9) approximately 1 mm and tighten fastener to 22 Nm (16 lb ft). Ensure the liftgate striker is properly centered in the latch opening, per step 7 below. Then re-check liftgate softness and if necessary re-adjust the striker again until liftgate softness is gone. Reinstall the liftgate striker trim cover (8) into the sill plate.

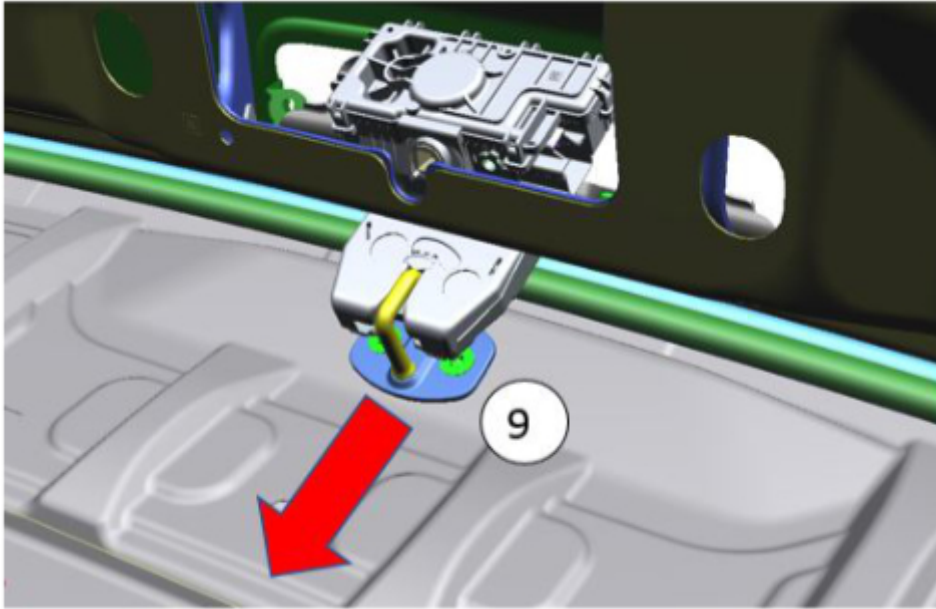

7. Inspect the liftgate strike to make sure it is centered in the liftgate latch opening (10). Observe the liftgate striker for wear on one side of the striker. In most cases, wear marks will be seen on the driver's side of the striker. If this is the case, loosen and adjust the striker to the passenger side 2 mm and tighten fastener to 22 Nm (16 lb ft). Adjust as necessary.

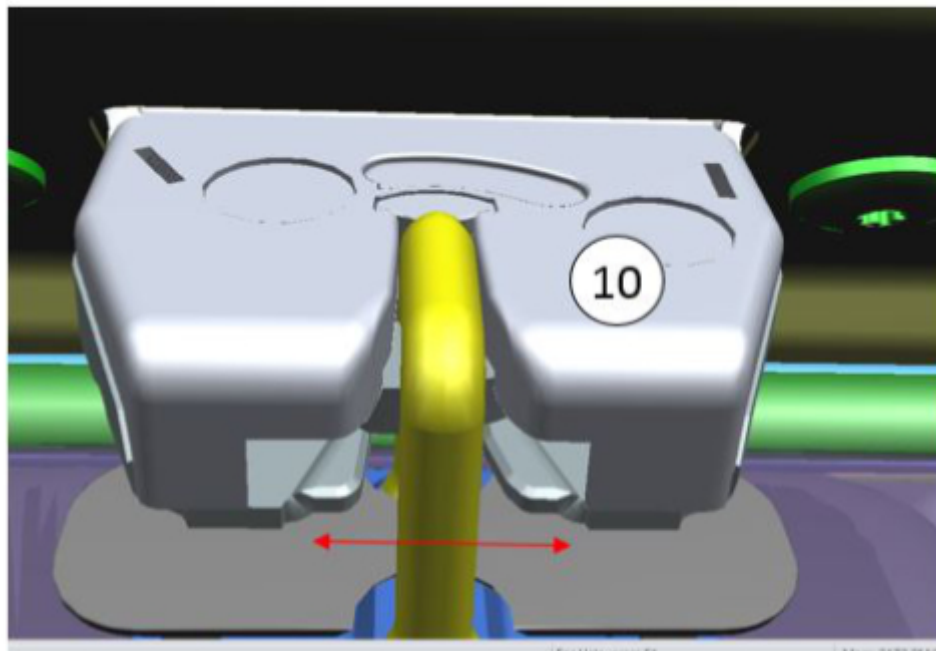

8. After performing the above repairs, retest the vehicle to see if the rattle has been corrected. If so, then no further repairs are needed. If a rattle noise is still present and has been isolated to the liftglass, proceed to step 9.

9. Only perform this step if all other checks and adjustments listed in this document have been addressed and the noise is still present and confirmed to be coming from the liftglass. Remove the liftglass latch and slot the mounting holes 1.5 mm using a suitable tool in the area shown below (11). Reinstall the liftglass latch, and while

holding the latch in the forward position, tighten the fasteners.

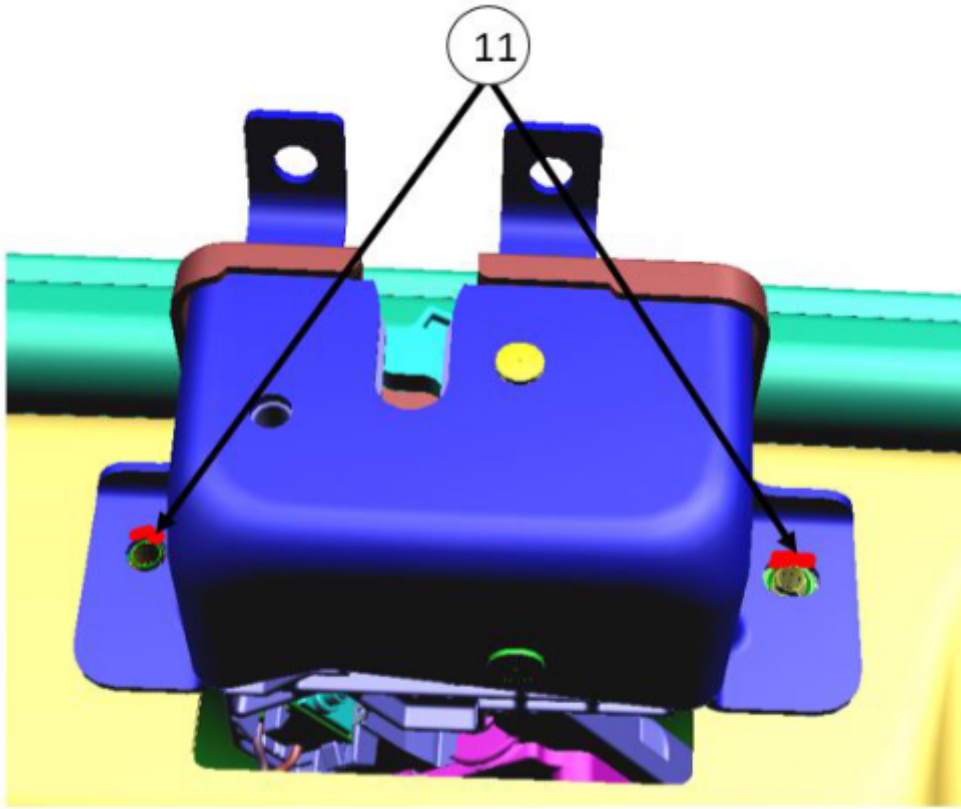

Parts Information

Description	Part Number
Super Lube Paste	12371287

Warranty Information

For vehicles repaired under the Bumper-to-Bumper coverage (Canada Base Warranty coverage), use the following labor operation. Reference the Applicable Warranties section of Investigate Vehicle History (IVH) for coverage information.

Labor Operation	Description	Labor Time
*1481408	Road Test and Perform Steps 1 through 8	1.5 hrs
Add Time	If Necessary To Complete Step 9	0.5 hrs
*This is a unique Labor Operation for Bulletin use only.		

Version History

Version	1
Modified	08/25/2020 - Created on.



© 2020 General Motors. All Rights Reserved.