

Classification:

Reference:

 COPYRIGHT© NISSAN NORTH AMERICA, INC.
 Date:

EM20-006

ITB20-019

August 10, 2020

VK56 CONNECTING ROD CAP BOLT SERVICE INFORMATION

APPLIED VEHICLES: 2004-2013 QX56 (JA60/Z62)
 2014-2019 QX80 (Z62)

SERVICE INFORMATION

A change has been made to the connecting rod cap bolt service part. The new service part (B in Figure 1) is visually different, but is a direct replacement for the original equipment part.

IMPORTANT: See page 2 for the procedure to inspect the cap bolt service part for excessive stretch.

If replacement of a single connecting rod cap bolt is indicated for any given connecting rod, both connecting rod cap bolts of the affected connecting rod must be replaced as a set.

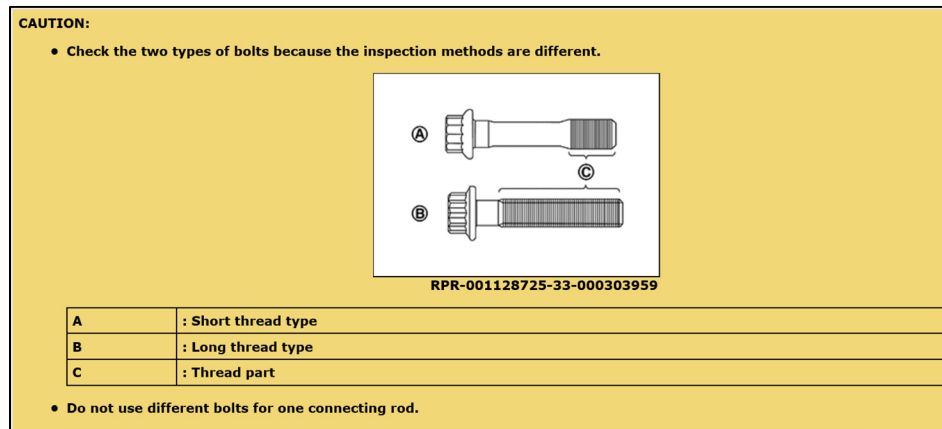

Figure 1

Infiniti Bulletins are intended for use by qualified technicians, not 'do-it-yourselfers'. Qualified technicians are properly trained individuals who have the equipment, tools, safety instruction, and know-how to do a job properly and safely. **NOTE:** If you believe that a described condition may apply to a particular vehicle, DO NOT assume that it does. See your Infiniti retailer to determine if this applies to your vehicle.

SERVICE PROCEDURE

Connecting Rod Cap Bolt Inspection

The following measurements are to be used when inspecting the service part for reuse.

- Measure the outer diameter at location (A) and location (B) shown in Figure 2.

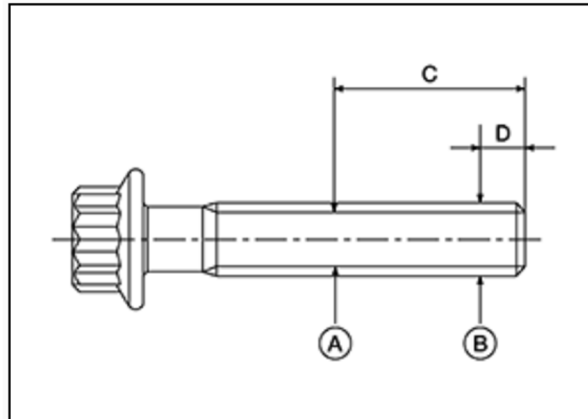

Figure 2

C	: 19 mm (0.75 in)
D	: 5 mm (0.20 in)

- Subtract (A) from (B).
Limit [(B) – (A)] : 0.15 mm (0.0059 in)
- If it exceeds the limit (large difference in dimensions), replace the bolt with a new one.

Connecting Rod Cap Bolt Torque Procedure

Tighten each connecting rod cap bolt as follows:

1. Apply engine oil to the threads and seats of the connecting rod cap bolts.
2. Tighten the connecting rod cap bolts to 29.4 N•m (3.0 kg-m, 21.7 ft-lb).
3. Loosen to 0 N•m (0 kg-m, 0 ft-lb).
4. Tighten the connecting rod cap bolts to 19.6 N•m (2.0 kg-m, 14.5 ft-lb).
5. Tighten 90° (+5°/-0°).

PARTS INFORMATION

DESCRIPTION	PART NUMBER	QUANTITY
Connecting Rod Cap Bolt	12109-1LA0B	As needed (1)

(1) Two (2) bolts are required for each connecting rod.

AMENDMENT HISTORY

PUBLISHED DATE	REFERENCE	DESCRIPTION
August 10, 2020	NTB20-019	Original bulletin published

