



## INSTRUCTION TO SERVICE

<b>ITS: 58910</b>	
<b>SECTION:</b>	203 FRONT SUSPENSION
<b>WRITTEN BY:</b>	Michael Rooney
<b>SUBJECT:</b>	Retrofitting new shock dust covers, height sensor & harness assembly. 40' Buses with Smart Rider on Front & Rear axles.

# ITS58910

**THIS ITS DOCUMENT SHOULD BE RETAINED AND REFERED TO FOR FUTURE MAINTENANCE UNTIL THE NEW FLYER PARTS AND/OR SERVICE MANUAL IS UPDATED TO REFLECT WORK DONE AS A RESULT OF THIS DOCUMENT. ENSURE THAT THIS DOCUMENT IS AVAILABLE FOR PARTS AND MAINTENANCE STAFF GOING FORWARD.**

THIS DOCUMENT AND THE CONTENTS DISCUSSED HEREIN ARE THE CONFIDENTIAL AND PROPRIETARY INFORMATION OF NEW FLYER INDUSTRIES CANADA ULC AND NEW FLYER OF AMERICA INC. AND ARE DISCLOSED BY NEW FLYER IN CONFIDENCE. THIS DOCUMENT AND THE CONTENTS HEREIN ARE NOT TO BE DISCLOSED BY THE INTENDED RECIPIENT WITHOUT THE PRIOR WRITTEN AUTHORIZATION OF NEW FLYER. ANY UNAUTHOIZED DISCLOSURE, REPRODUCTION OR OTHER DISTRIBUTION OF THIS DOCUMENT OR INFORMATION IS STRICTLY PROHIBITED AND MAY RESULT IN ACTION BEING TAKEN AGAINST THE PARTY MAKING THE UNAUTHORIZED DISCLOSURE. THIS DOCUMENT AND ALL COPIES HEREOF MUST BE RETURNED TO NEW FLYER UPON REQUEST.

## PROCEDURE:

1. Turn the main battery disconnect switch to the “OFF” position.
2. Drain the air from the air system.
3. Raise coach in accordance with the New Flyer Service Manual and install appropriate jack stands to support the vehicle.

## FRONT SUSPENSION

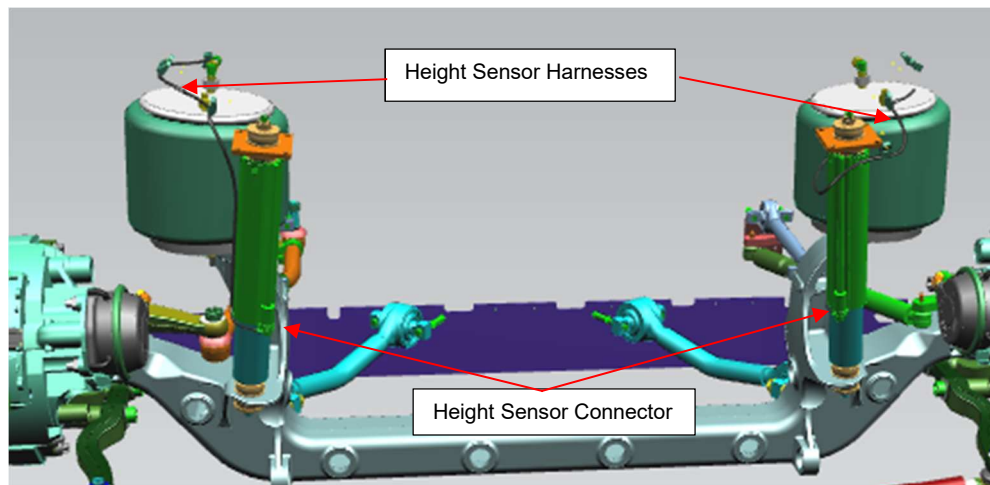
4. Use wheel lifts on the front suspension to lift the front suspension slightly to support the weight of the front axle and suspension components.

**⚠ Caution:** **ALWAYS support the weight of the axle when replacing shock absorbers.**

5. Disconnect the electrical connector that attaches the shock absorber height sensor to the vehicle harness.
  - a. Remove clamps used to attach the harness to the under body and set them aside.

**Note: If the harness is bundled and tyrapped around the shock dust cover, the harness must be rerouted when the shock absorber unit is reinstalled.**

6. Remove the four nuts retaining the upper shock mounting plate to the chassis bracket.
7. Remove the protective cap from the lower shock mounting nut and remove the nut.



**Figure 1: Front Shock Absorbers (Looking towards the front of the vehicle).**

8. Remove the clamping plate, rubber bushing and centering ring from the shock stud noting the location and orientation of the parts.
9. Compress the lower shock sufficiently to remove the shock stud from the lower mounting bracket. Remove the remaining rubber bushing from the shock stud.
10. Remove the shock absorber assembly from the vehicle and disassemble the upper mounting components as follows:
  - a. Remove the protective cap from the upper shock mounting nut and remove the nut.



## NEW FLYER

- b. Remove the clamping plate, rubber bushing and centering ring from the shock stud noting the location and orientation of the parts.
  - c. Remove the mounting plate, rubber bushing and steel sleeve from the shock stud.
11. Take the shock assembly to the work bench and secure the unit in a vice by the upper shock stud with the side of the dust cover containing the sensor channel facing upward.

**NOTE:** Use soft jaws in the vice to protect the threads on the upper shock stud from damage.

12. Using a rubber mallet, apply a sharp blow to the upper end of the dust cover at the square open end of the channel in the dust cover. The dust cover should pop loose from the shock absorber.



**Figure 2: Rubber Mallet Use To Release Dust Cover**

13. Slide the dust cover and sensor harness off the shock absorber body and set aside.
14. Install a new dust cover/sensor/harness assembly NF P/N 6482203 over the shock body.
- a. Align the square section channel with the magnet on the outside of the shock body and slide the dust cover over the shock body. Center the opening in the top of the dust cover with the grey circular retaining ring below the bushing on the shock stud.



**Figure 3: Install Dust Cover & Center Over Grey Retaining Ring.**

- b. Using a rubber mallet, apply a sharp blow to the bottom of the dust cover to seat the cover on the grey circular retaining ring. Take care not to hit the height sensor connector.



**Figure 4: Using Rubber Mallet To Seat Dust Cover on Retaining Ring.**

15. Install the dirt exclusion cover at the top of the dust cover.



**Figure 5: Dirt Exclusion Cover.**

16. Assemble the upper shock mounting components as follows:

- a. Slide the steel sleeve and rubber bushing onto the shock stud. Ensure that the flat side of the rubber bushing seats against the shock body.
- b. Place the mounting plate onto the rubber bushing ensuring that the mounting plate seats on the pilot diameter of the rubber bushing.

17. Assemble the remaining upper shock mounting components as follows:

- a. Slide the centering ring and rubber bushing onto the shock stud ensuring that the pilot diameter of the rubber bushing seats within the concave side of the centering ring.
- b. Install the clamping plate onto the rubber bushing ensuring that the concave side of the clamping plate seats against the flat side of the rubber bushing.
- c. Install the M16 self-locking nut and torque to 56 Ft lbs using NEVER SEEZ NF P/N 5928660.
- d. Install the protective cap over the lock nut.

18. Align the four holes in the upper shock mount plate with the studs on the chassis mounting bracket.

19. Install four lock nuts NF P/N 203772 and torque the lock nuts to 35 Ft lbs using NEVER SEEZ NF P/N 5928660.

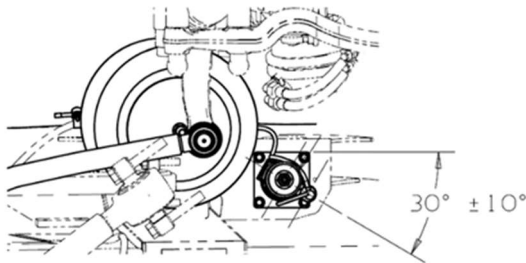
20. Assemble the remaining lower shock mounting components as follows:

- a. Slide the rubber bushing onto the shock stud ensuring that the flat side of the rubber bushing seats against the shock body.
- b. Compress the shock sufficiently to allow the shock stud to enter the lower mounting bracket.

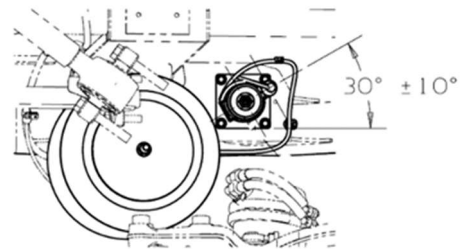


## NEW FLYER

21. Assemble the remaining lower shock mounting components as follows:
- Slide the centering ring and rubber bushing onto the shock stud ensuring that the pilot diameter of the rubber bushing seats within the concave side of the centering ring.
  - Install the clamping plate onto the rubber bushing ensuring that the concave side of the clamping plate seats against the flat side of the rubber bushing.
  - Clock the dust cover height sensor cavity approx. 30 degrees off the center line of the bus to ensure that the upper mounting plate nuts are not aligned with the end of the height sensor cavity in order to create better clearance and prevent contact between the bolt and the cover.
  - Install the M16 self-locking nut and torque to 56 Ft lbs using NEVER SEEZ NF P/N 5928660. Take care that the dust cover does not rotate out of position when torquing the nut.
  - Install protective cap over the lock nut.

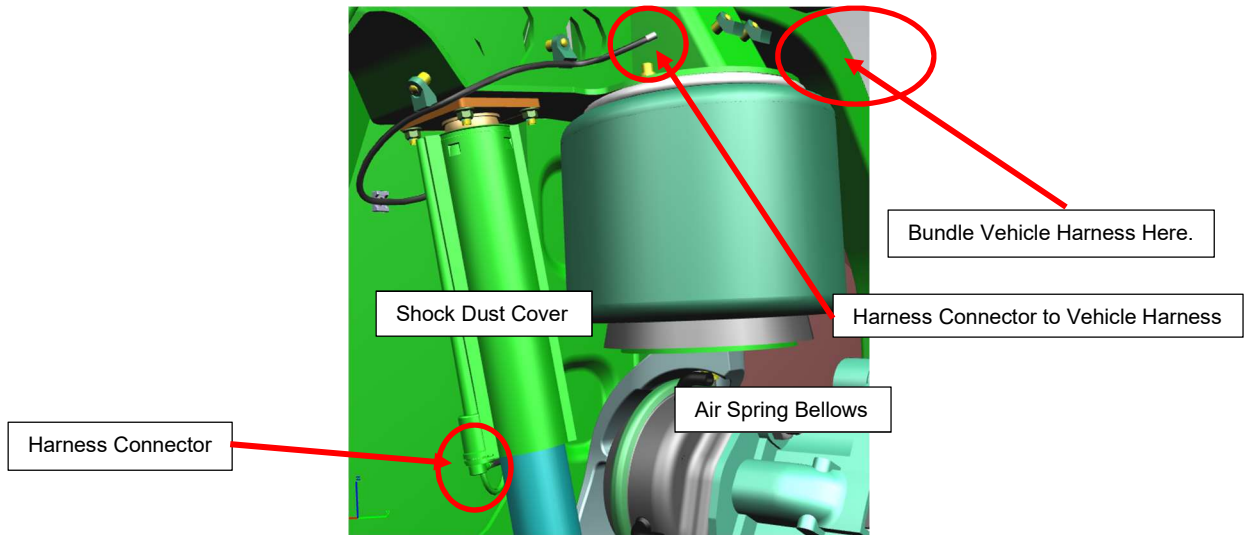


**Figure 6A: Street Side Dust Cover Orientation.**

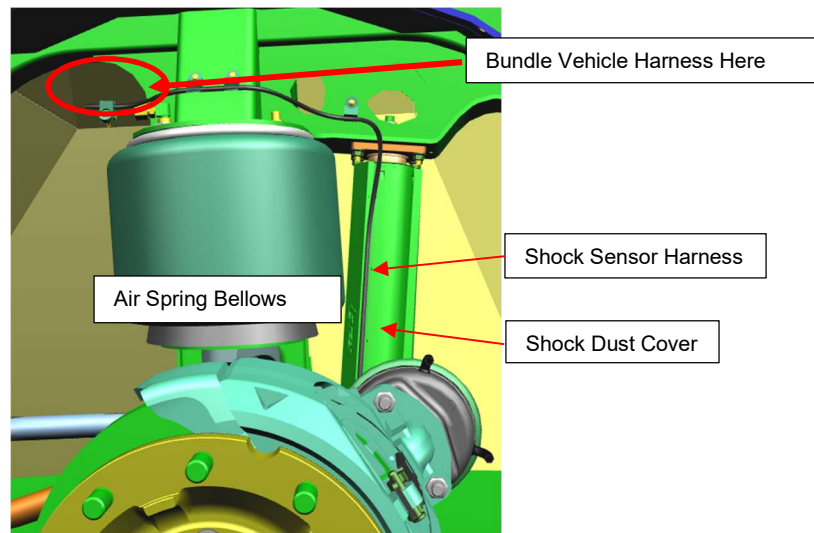


**Figure 6B: Curb Side Dust Cover Orientation.**

22. Connect the height sensor harness to the vehicle harness. Take care to ensure that the screw connector is tight and secure.
- Route the shock sensor harness using the existing harness retaining clips. Bundle the remaining vehicle harness length and secure with tie wraps NF P/N 5955945.



**Figure 7: Curbside Shock Sensor Harness Routing.**



**Figure 8: Curbside Shock Sensor Harness Routing.**

**REAR SUSPENSION**

23. Use wheel lifts on the rear suspension to lift the rear suspension slightly to support the weight of the rear axle and suspension components.

**⚠ Caution: ALWAYS support the weight of the axle when replacing shock absorbers.**

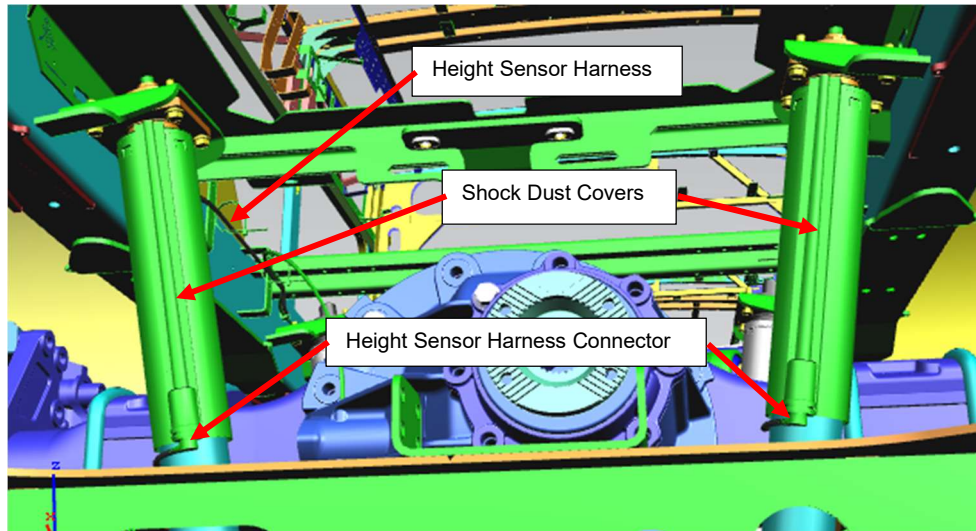
24. Locate the height sensor harness wires on the rear set of shock absorbers and remove the hardware that secures the harness wires to the bus. Note the locations of each clip and set them aside for reuse later. Disconnect each of the harnesses at the connectors where they attach to the main vehicle harness.



## NEW FLYER

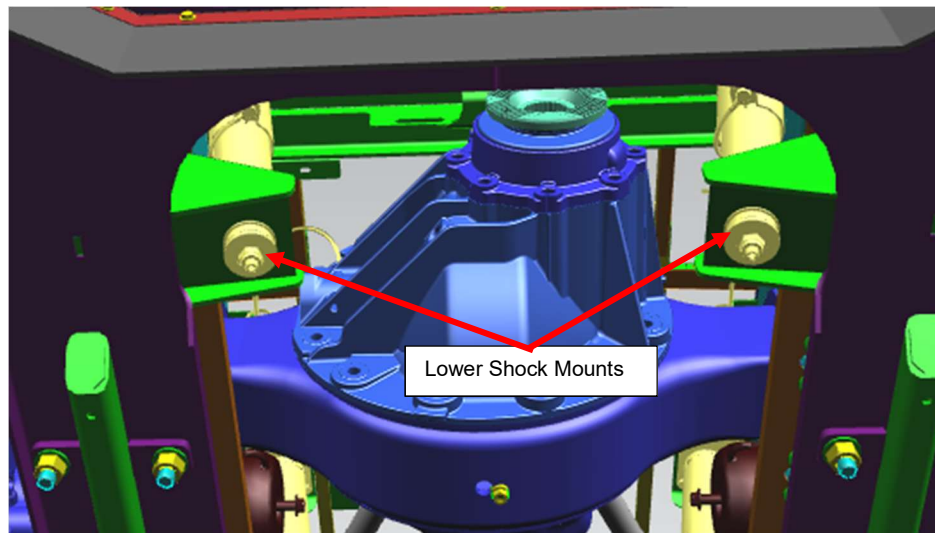
25. Remove the four nuts retaining the upper shock mounting plate to the chassis bracket on each side. Set the hardware aside for reuse.

**Note:** The two inboard mounting bolts that retain the air-line support bracket are slightly longer to accommodate the thickness of the bracket. Note the location of these bolts for reassembly.



**Figure 9: Rear Shock absorbers upper hardware (drive shaft removed for clarity).**

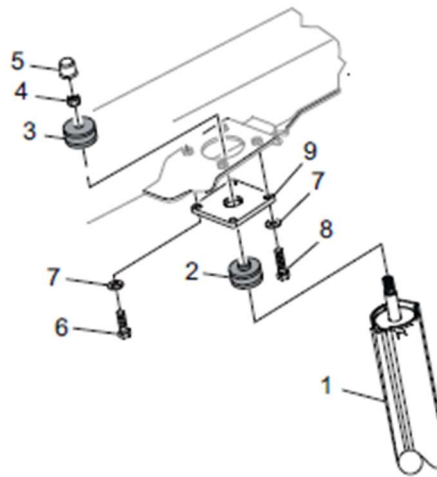
26. Remove the protective caps from the lower shock mounting nuts and remove the nuts.
27. Remove the rubber bushings from the shock studs, noting the location and orientation of the parts.
28. Compress the lower shocks sufficiently to remove the shock studs from the lower mounting brackets.
29. Remove the remaining rubber bushings from the shock stud.
30. Remove the shock absorber assemblies from the vehicle.



**Figure 10: Rear Shock absorbers lower hardware (drive shaft removed for clarity).**

31. Take the shock absorbers to the work bench. Procedure for removal and replacement of the dust covers on the rear shocks is the same as for the front shocks. See Steps #10 to #15 for the R&R procedure.
32. Assemble the upper shock mounting components as follows:
  - a. Slide the rubber bushing onto the shock stud. Ensure that the flat side of the rubber bushing seats against the dirt excluder.
  - b. Place the mounting plate onto the rubber bushing ensuring that the mounting plate seats on the pilot diameter of the rubber bushing.
33. Assemble the remaining upper shock mounting components as follows:
  - a. Slide the rubber bushing onto the shock stud ensuring that the pilot diameter of the rubber bushing seats on the mounting plate.
  - b. Install the clamping plate onto the rubber bushing ensuring that the concave side of the clamping plate seats against the flat side of the rubber bushing. Install the M16 self-locking nut and torque to 56 Ft – Lbs using Never Seize NF P/N 5928660 on the threads.
  - c. Install the protective cap over the lock nut.

1. Shock Absorber Assembly
2. Bushing, Rubber
3. Bushing, Rubber
4. Nut, Hex Locking
5. Cap
6. Bolt, Hex 3/8" x 1 1/4" Lg
7. Washer, Flat Hardened
8. Bolt, Hex 3/8" x 1 1/2" Lg
9. Plate, Shock Mount



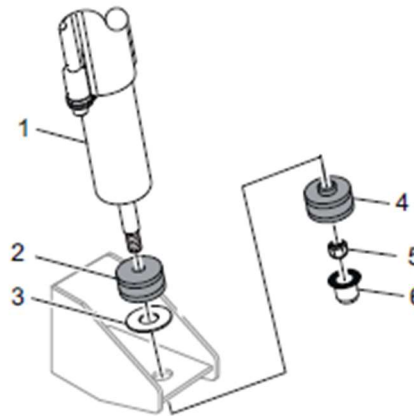
**Figure 11: Rear Shock absorbers Upper hardware detail.**

34. Align the four holes in the upper shock mount plate with the welded nuts on the chassis mounting bracket.
35. Position the air line support bracket over the two holes on the inboard side of the mount plate.
36. Install the four bolts and washers and torque to 23 Ft Lbs using Never Seize NF P/N 5928660 on the threads.

**Note: The two inboard mounting bolts that retain the air-line support bracket are slightly longer to accommodate the thickness of the bracket. Ensure that the two longer bolts are installed at the bracket location.**

37. Assemble the lower shock mounting components as follows:
  - a. Slide the rubber bushing and shock mount plate onto the shock stud ensuring that the flat side of the rubber bushing seats against the shock body.
  - b. Compress the shock sufficiently to allow the shock stud to enter the lower mounting bracket.
38. Assemble the remaining lower shock mounting components as follows:
  - a. Slide the centering ring and rubber bushing onto the shock stud ensuring that the pilot diameter of the rubber bushing seats within the concave side of the centering ring.
  - b. Install the clamping plate onto the rubber bushing ensuring that the concave side of the clamping plate seats against the flat side of the rubber bushing.
  - c. Clock the dust covers on the shock absorbers so that the molded plug on the sensor harness faces the rear of the vehicle as seen in Figure 9.
  - d. Install the M16 self-locking nut and torque to 56 Ft -Lbs using Never Seize NF P/N 5928660 on the threads. Ensure that the dust cover does not rotate when the M16 nut is torqued.
  - e. Install the protective cap over the lock nut.

1. Shock Absorber Assembly
2. Bushing, Rubber
3. Plate, Shock Mount
4. Bushing, Rubber
5. Nut, Hex Locking M16x 1.5"
6. Cap



**Figure 12: Rear Shock absorbers Lower hardware detail.**

39. Route the height sensor harnesses forward and connect them to the vehicle wiring harness. Take care to ensure that the screw connector is tight and secure.
40. Secure the height sensor harnesses to the vehicle chassis using the original hardware.
41. Lower the bus in accordance with the New Flyer Service Manual.
42. Turn the main battery disconnect switch to the "ON" position.
43. Ensure that the latest version 21 Smart Rider software is loaded in the bus. The software is available from your regional product support manager (RPSM).
44. Perform a ride height sensor calibration. Refer to Section 8 of the Service Manual for the calibration procedure.
45. Road test the bus to ensure proper operation
46. Remove all tools and debris and return the bus to service condition.



## NEW FLYER

### LABOUR ESTIMATE

	Operation	People	Hours	Labor Time
1	Retrofitting new shock dust covers, height sensor & harness assembly.	1	3.0	3.0

### PARTS REQUIRED

Item	Part Number	Description	Qty. per Coach	Units	Notes
1	6482203	SENSOR ASSY-RIDE HEIGHT	4	EA	
2	5955945	TYRAP – 14.0 BLACK	9	EA	
3	5928660	NEVER SEIZE	0.03	EA	

### SPECIAL TOOLS REQUIRED

Item	Part Number	Description	Qty. per Coach	Units	Notes
		No Special Tools Required			