

WLH5 - Checking Plug Connection for Water Drain Hose and Connecting it Correctly if Necessary (Workshop Campaign)

Model Line: **Taycan (Y1A)**

Model Year: **2020**

Subject: **Water drain hose on heating/fresh-air unit**

Information: **There is a possibility that the condensed water drain hose was not installed correctly on the heating/fresh-air unit on the affected vehicles.**

As a result, condensed water can escape into the right footwell when using the air conditioning.

Remedial Action: Check the water drain hose on the heating/fresh-air unit and install it correctly if necessary.

Affected Vehicles: Only vehicles assigned to the campaign (see also PCSS Vehicle Information). This campaign affects 1,886 vehicles in North America.

Installation

Position:

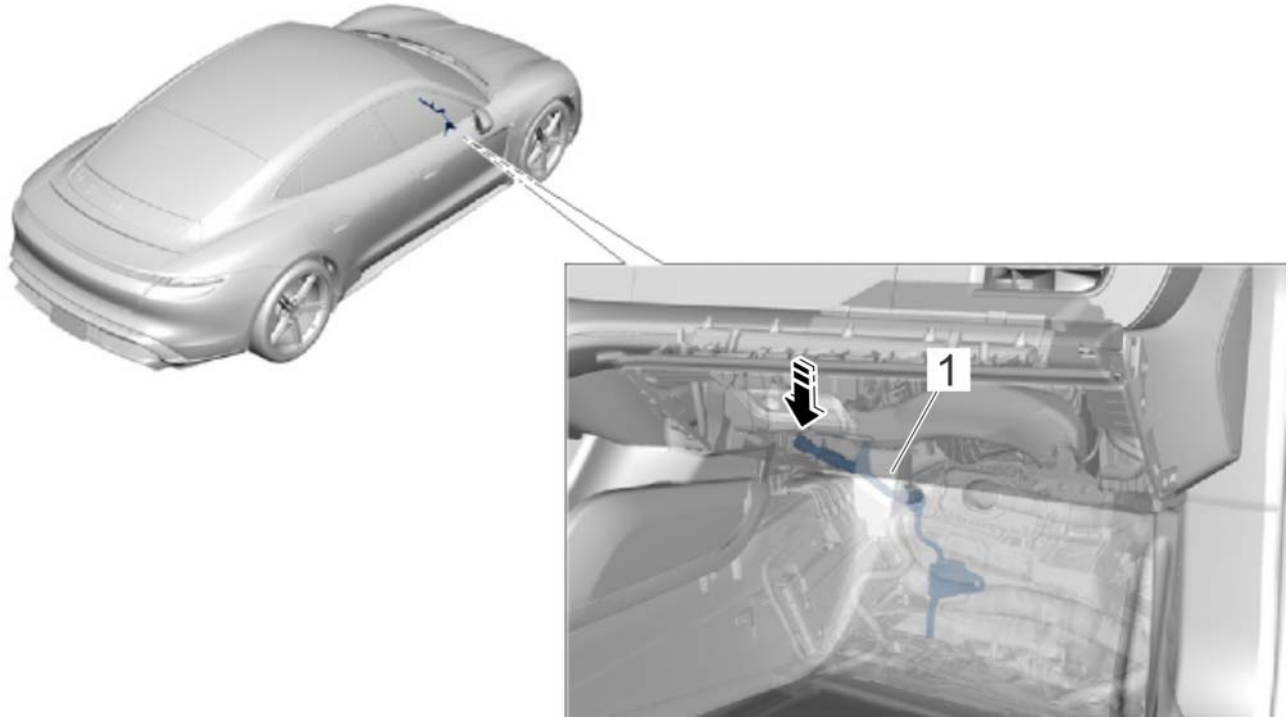

Installation position of water drain hose

1 – Water drain hose for heating/fresh-air unit

Arrow – Drain hose to heating/fresh-air unit plug connection (**check and install correctly if necessary**)

Required tools

- Tools:
- Plastic disassembly wedge
 - Flashlight

Checking plug connection for water drain hose

- Work Procedure: 1 Remove the footwell light in the front right footwell.
For instructions, see ⇒ *Workshop Manual '961519 Removing and installing footwell light'*.
- 2 Remove the cover in the right footwell under the dashboard.
To do this, unscrew fixing clips ⇒ *Removing lower dashboard cover -1-* and pull off the cover under the dashboard ⇒ *Removing lower dashboard cover -2-*.

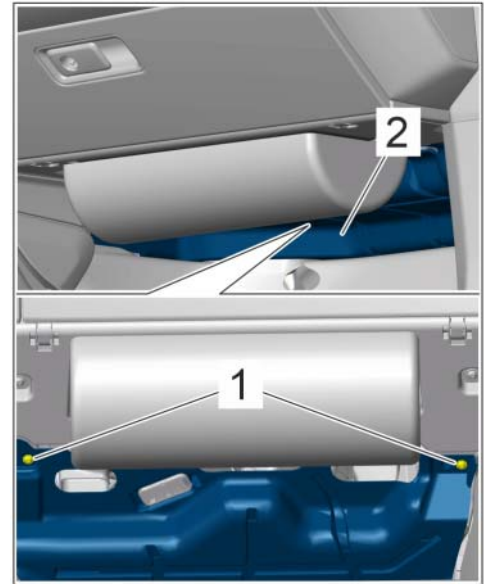

Removing lower dashboard cover

- 3 Check plug connection between water drain hose and heating/fresh-air unit.
 - The **water drain hose is installed fully until it engages** on the connection on the heating/fresh-air unit ⇒ *Water drain hose installed correctly*. No further action required, continue with **Step 5**.

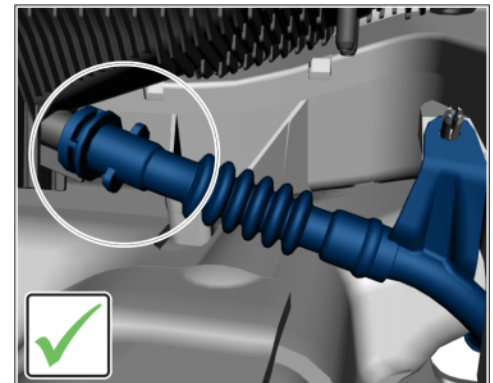

Water drain hose installed correctly

- **The water drain hose is loose or not installed fully until it engages** on the connection on the heating/fresh-air unit ⇒ *Water drain hose loose or not fully installed*: Install the water drain hose correctly on the connection of the heating/fresh-air unit and continue with **Step 4**.

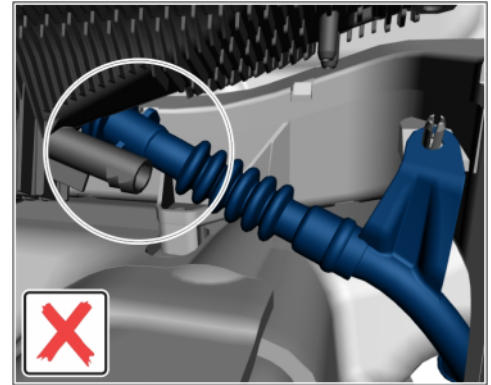

Water drain hose loose or not fully installed

- 4 Install the water drain hose onto the connection on the heating/fresh-air unit.
 - 4.1 Loosen clip on water drain hose holder ⇒ -2-.
 - 4.2 Position water drain hose in front of the connection on the heating/fresh-air unit ⇒ -1- and **push it** onto the connection of the heating/fresh-air unit **fully until it engages** ⇒ -Arrow-.
 - 4.3 Secure clip on water drain hose holder ⇒ -2-.

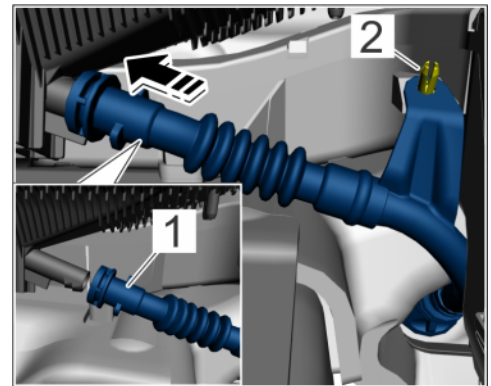

Connecting water drain hose

- 5 Install the cover in the right footwell under the dashboard.
To do this, position the cover under the dashboard ⇒ *Installing lower dashboard cover -2-* and screw in the fixing clips ⇒ *Installing lower dashboard cover -1-*.

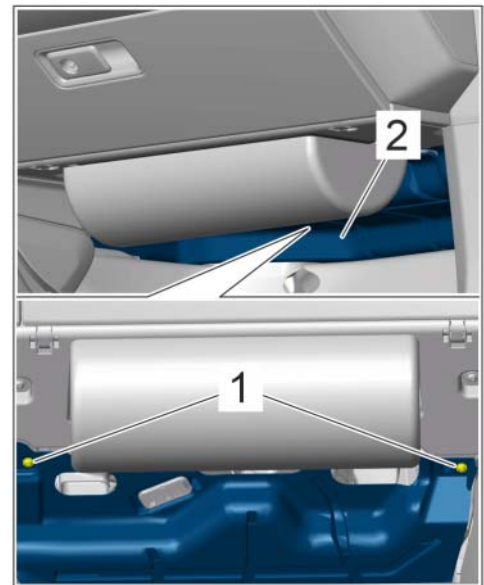

Installing lower dashboard cover

- 6 Install the footwell light in the front right footwell.
For instructions, see ⇒ *Workshop Manual '961519 Removing and installing footwell light'*.
- 7 Enter the campaign in the Warranty and Maintenance booklet.

Warranty processing

Scope 1: **Checking plug connection for water drain hose** – the water drain hose is installed correctly

Working time:	
Checking plug connection for water drain hose	Labor time: 12 TU
Includes:	
Removing and installing right footwell light	
Removing and installing cover in right footwell under dashboard	
⇒ Damage Code WLH5 066 000 1	

Scope 2: **Checking plug connection for water drain hose and connecting it correctly**

Working time:

Checking plug connection for water drain hose and connecting it correctly

Labor time: **18 TU**

Includes:

Removing and installing right footwell light

Removing and installing cover in right footwell under dashboard

⇒ **Damage Code WLH5 066 000 1**

All tasks required for correcting consequential damage due to a loose/disconnected water drain hose are not included in the scope of this campaign and must be invoiced using a separate PCSS job line coded to the part ID 8521.

Important Notice: Technical Bulletins issued by Porsche Cars North America, Inc. are intended only for use by professional automotive technicians who have attended Porsche service training courses. They are written to inform those technicians of conditions that may occur on some Porsche vehicles, or to provide information that could assist in the proper servicing of a vehicle. Porsche special tools may be necessary in order to perform certain operations identified in these bulletins. Use of tools and procedures other than those Porsche recommends in these bulletins may be detrimental to the safe operation of your vehicle, and may endanger the people working on it. Properly trained Porsche technicians have the equipment, tools, safety instructions, and know-how to do the job properly and safely. Part numbers listed in these bulletins are for reference only. The work procedures updated electronically in the Porsche PIWIS diagnostic and testing device take precedence and, in the event of a discrepancy, the work procedures in the PIWIS Tester are the ones that must be followed.

© 2020 Porsche Cars North America, Inc.